



DOE / NRCAN Model Information Inside

# SM/SV Series

PRODUCT COOLERS

Datasheet: 3240825 Rev. C



Products that provide lasting solutions.

# SM/SV Series Unit Coolers

## DOE Evaporator Compliant Matrix

	SM / SV	
	DUAL SPEED MOTORS	VARIABLE SPEED MOTORS
<b>DEFROST TYPE</b>		
<b>Air</b>		
Glide Refrigerants*	X (Except SM*14A, SM*24A, SM*26A-0746, SM*27A-0811, SM*34A-1123 and 1243, SM*36A-1289, SM*37A-1402, SM*44A-1532 and 1829, SM*46A-1846)	X
Non-Glide Refrigerants (Including CO2) **#	X (Units Available: SM*16A-0538 and 604, SM*17A-0585 and 0657, SM*27A-1296, and SM*47A-2581)	X
<b>Electric</b>		
<b>Glide Refrigerants*</b>		
Coolers	X (Except SM*14E-0384, SM*24E-0759, SM*34E-1070, SM*36E-1225, SM*46E-1754)	X
Freezers	X (Except ALL SV Models)	X
<b>Non-Glide Refrigerants (Including CO2)**#</b>		
Coolers	-	X
Freezers	-	X
<b>Gas</b>		
<b>Glide Refrigerants*</b>		
Coolers	X (Except SM*14( )-0384, SM*24( )-0759, SM*34( )-1070, SM*36( )-1225, SM*46( )-1754)	X
Freezers	X	X
<b>Non-Glide Refrigerants (Including CO2)**#</b>		
Coolers	-	X
Freezers	-	X
<b>MOTOR VOLTAGES / PHASE (All 60 HZ)</b>		
115/1	-	-
208-230/1	-	-
208-230/3	X	X
460/1	-	-
460/3	X	X
575/3	-	-

X - Available

\* Glide Refrigerants (R-407A, R-407F, R-448A, R-449A, refer to I/O Manual for Others). Models in tables with "\*" are not tied to this note.

\*\* Non-Glide Refrigerants (R-404A, R-507A, refer to I/O Manual for Others)

<sup>2</sup> Only on Multiple Fan Units Wired for Three Phase Operation

# CO<sub>2</sub> SM/SV are not DOE compliant



DOE / NRCan -

The SM series of evaporators are designed for long life with testing and options to meet efficiency required by DOE and NRCan regulations. SV models have longer air throw for application in larger freezer applications.



CO<sub>2</sub> products defined as "standard pressure" are rated for use up to 640 PSI (44.1 bar). CO<sub>2</sub> products defined as "high pressure" are rated for use up to 1,160 PSI (80 bar).



# SM/SV Series Unit Coolers

Photo on front cover shown  
with optional Long Throw  
Air Boosters

## Standard Features

### SM SERIES -

#### Ideal for Warehouse Coolers or Freezer with a Wide Range of Capacities

- Ruggedly constructed cabinets are installed pulled against the ceiling or with hanger rods sloped towards the drain connection on the end of the unit.
- Efficient draw-thru design with 30" diameter aluminum fan blades provide air throw of 60 feet.
- High efficiency 1 horsepower 3 phase motors operate fans at 850 RPM.
- Wide capacity range with coils with 4, 5, 6, or 7 fins per inch.
- Air defrost models for rooms operating above 34° F.
- Electric and hot gas defrost models for colder rooms and freezers.
- Mill galvanized drain pan and fan cabinet.
- Coated, corrosion-resistant wire fan guards.
- Insulated drain pan on electric and gas defrost models.
- Drain pan and fan cabinet end panels are hinged for easy access and cleaning.
- Factory-wired fans and defrost controls to convenient terminal strips for field connections.
- Adjustable defrost termination and fan delay thermostat installed with electric defrost.
- Coil constructed of heavy-wall copper tube and rippled full collar aluminum fins.
- Optimized circuiting based on refrigerant type.
- Sealed and pressurized from the factory.

#### Optional Features and Accessories

- Variable Speed EC with brushless permanent magnet motor and panel mounted electronic drive.
- Installed thermostat and controller options for simple Dual Speed or Variable Speed EC fan control.
- Hot gas defrost models available with gas or electric pan heat.
- Coils circuited for fluids operating as a secondary coolant.
- Installed mechanical or electronic expansion valves.
- Liquid line solenoid valve installed or ship loose.
- Painted white or black housing and drain pans.
- Stainless-steel housing and drain pans in place of galvanized steel.
- Insulated drain pan on air defrost models.
- Copper fins or coil coating from Electrofin or Heresite.
- Long throw adapters increase air throw to 100 feet.

### SV SERIES -

#### Designed to Deliver Low Temperature Air at High Velocity in Freezers

- Ruggedly constructed cabinets are installed pulled against the ceiling or with hanger rods sloped towards the drain connection on the end of the unit.
- Efficient draw-thru design with 30" diameter aluminum fan blades provide air throw of 80 feet.
- High efficiency 1-1/2 horsepower 3 phase motors operating fans at 1140 RPM.
- Wide capacity range with coils with 4, 5, or 6 fins per inch.
- Electric and hot gas defrost models for low temperature rooms.
- Mill galvanized drain pan and fan cabinet.
- Coated, corrosion-resistant wire fan guards.
- Insulated drain pan on electric and gas defrost models.
- Drain pan and fan cabinet end panels are hinged for easy access and cleaning.
- Factory-wired fans and defrost controls to convenient terminal strips for field connections.
- Adjustable defrost termination and fan delay thermostat installed with electric defrost.
- Coil constructed of heavy-wall copper tube and rippled full collar aluminum fins.
- Optimized circuiting based on refrigerant type.
- Sealed and pressurized from the factory.

#### Optional Features and Accessories

- Variable Speed EC with brushless permanent magnet motor and panel mounted electronic drive.
- Installed thermostat and controller options for simple Dual Speed or Variable Speed EC fan control.
- Hot gas defrost models available with gas or electric pan heat.
- Installed mechanical or electronic expansion valves.
- Liquid line solenoid valve installed or ship loose.
- Painted white or black housing and drain pans.
- Stainless-steel housing and drain pans in place of galvanized steel.
- Copper fins or coil coating from Electrofin or Heresite.
- Long throw adapters increase air throw to 120 feet.

# SM/SV Series Unit Coolers

## Ordering Information

Specify When Ordering All Models

- Complete model number including refrigerant
- Room temperature
- Evaporating temperature
- Liquid refrigerant temperature
- Optional features
- Optional accessories

## Model Key

	SM	A	2	5	E	-	0842	T	C	K	K
--	----	---	---	---	---	---	------	---	---	---	---

**Unit Type**

SM - Space Master  
SV - High Velocity

**DOE Application**

D - DOE and NRCan  
A - Non-Regulated

**Number of Fans**

4, 5, 6, 7 FPI

**Fin Spacing**

4, 5, 6, 7 FPI

**Type of Defrost**

A - Air Defrost  
E - Electric Defrost w/Electric Pan Heat  
G - 3 Pipe Hot Gas w/Gas Pan Heat#  
H - 3 Pipe Hot Gas w/Electric Pan Heat#  
K - 2 Pipe Kool Gas w/Gas Pan Heat##  
P - 2 Pipe Kool Gas w/Electric Pan Heat##  
R - Heat Reclaim#

**Heater Voltage**

K - 208-230/3/60  
M - 460/3/60  
P - 575/3/60  
U - 380/3/50  
L - 380/3/60\*

**Motor Voltage**

K - 208-230/3/60  
M - 460/3/60  
P - 575/3/60  
U - 380/3/50  
L - 380/3/60\*

**Motor Type\*\*\***

C - 3 Phase Motors\*\*  
V - Variable Speed EC, 3 Phase  
D - Variable Speed EC, Dual Speed Control

**Refrigerant**

N - Stock Unit****	G - Stock Unit*****
S - R-404A	Q - R-407A T - R-448A
P - R-507A	F - R-407F R - R-449A

B - Glycol / Brine  
H - CO<sub>2</sub> (high pressure)

**BTU/H in Hundreds (00)**



\* Contact application engineering for quoting.

\*\* Inverter suitable motor for K, M, P, and U voltages with 3 phase motors.

\*\*\* Available in K, M, U, and L motor voltages. DOE and NRCan applications with Dual Speed or Variable Speed EC control.

\*\*\*\* N Stock Units are for non-glide or glide refrigerants (consult I/O manual for complete refrigerant listing).

\*\*\*\*\* G Stock Units are for glide refrigerants only (consult I/O manual for complete refrigerant listing).

# G, H, and R defrost types not available for CO<sub>2</sub> (H) refrigerant.

## K and P defrost types H refrigerant will be available soon.



### DOE / NRCan -

Indicates evaporator models that have an AWEF rating published which meets the efficiency requirements of the US Department of Energy and Natural Resources Canada regulations. These specific regulations are for evaporators manufactured after July 10th, 2020, applied in refrigerated spaces 3000 square feet or less, and held at 55° F room temperature or colder. Not covered in this regulation are unit coolers using secondary refrigerant like glycol.

Hussmann / Krack will ship DOE / NRCan compliant evaporator coil units for regulated / covered applications to meet and adhere with government labeling requirements. **Please note that compliance is at the time of manufacture and responsibility of the OEM.**

The DOE / NRCan compliant evaporators will utilize Dual Speed or Variable Speed EC motors. Controls for these options may be factory installed or field supplied.

Both the Dual Speed and Variable Speed EC motors have default prevention programming. In the event of a control loss input (OV), the motors will run at full speed.

# SM/SV Series Unit Coolers

## Air Defrost High Profile

### AIR DEFROST

MODEL	COOLER AWEF BY REFRIGERANT and MOTOR*				CAPACITY (BTU/H) @ 10° F TD +25° F EVAP	AIR FLOW (CFM)	REFRIGERATION CONNECTIONS		REF CHARGE (LBS)	DIMENSIONS (IN)			SHIP WGT (LBS)
	[G] STOCK UNIT**, [Q] R-407A, [F] R-407F, [T] R-448A, [R] R-449A		[N] STOCK UNIT***, [S] R-404A, [P] R-507A				LIQ	SUCT		L	W	H	
	{D}ual Speed	{V}ariable Speed	{D}ual Speed	{V}ariable Speed									
SM*14A-0314[ ] { }	N/A	9.00	N/A	9.00	31,400	9,860	N/A	1-3/8"	10	77.0	38.5	40.5	410
SM*16A-0378[ ] { }	9.00	9.00	N/A	9.00	37,800	8,980	N/A	1-3/8"	10	77.0	38.5	40.5	445
SM*17A-0410[ ] { }	9.00	9.00	N/A	9.00	41,000	8,550	N/A	1-3/8"	10	77.0	38.5	40.5	465
SM*14A-0403[ ] { }	N/A	9.00	N/A	9.00	40,300	9,690	N/A	1-5/8"	13	77.0	38.5	40.5	430
SM*16A-0463[ ] { }	9.00	9.00	N/A	9.00	46,300	8,810	N/A	1-5/8"	13	77.0	38.5	40.5	470
SM*17A-0503[ ] { }	9.00	9.00	N/A	9.00	50,300	8,390	N/A	1-5/8"	13	77.0	38.5	40.5	490
SM*14A-0469[ ] { }	9.00	9.00	N/A	9.00	46,900	9,510	N/A	1-5/8"	16	77.0	38.5	40.5	450
SM*16A-0538[ ] { }	9.00	9.00	9.00	9.00	53,800	8,480	N/A	1-5/8"	16	77.0	38.5	40.5	495
SM*17A-0585[ ] { }	9.00	9.00	9.00	9.00	58,500	8,100	N/A	1-5/8"	16	77.0	38.5	40.5	515
SM*14A-0526[ ] { }	9.00	9.00	N/A	9.00	52,600	9,330	N/A	2-1/8"	19	77.0	38.5	40.5	484
SM*16A-0604[ ] { }	9.00	9.00	9.00	9.00	60,400	8,400	N/A	2-1/8"	19	77.0	38.5	40.5	530
SM*17A-0657[ ] { }	9.00	9.00	9.00	9.00	65,700	8,000	N/A	2-1/8"	19	77.0	38.5	40.5	550
SM*24A-0619[ ] { }	N/A	9.00	N/A	9.00	61,900	19,700	N/A	2-1/8"	18	134.3	38.5	40.5	830
SM*26A-0746[ ] { }	N/A	9.00	N/A	9.00	74,600	17,900	N/A	2-1/8"	18	134.3	38.5	40.5	885
SM*27A-0811[ ] { }	N/A	9.00	N/A	9.00	81,100	17,100	N/A	2-1/8"	18	134.3	38.5	40.5	940
SM*24A-0797[ ] { }	N/A	9.00	N/A	9.00	79,700	19,380	N/A	2-5/8"	24	134.3	38.5	40.5	836
SM*26A-0915[ ] { }	9.00	9.00	N/A	9.00	91,500	17,600	N/A	2-5/8"	24	134.3	38.5	40.5	895
SM*27A-0995[ ] { }	9.00	9.00	N/A	9.00	99,500	16,800	N/A	2-5/8"	24	134.3	38.5	40.5	950
SM*24A-0882[ ] { }	N/A	9.00	N/A	9.00	88,200	18,890	N/A	2-5/8"	30	134.3	38.5	40.5	845
SM*26A-1063[ ] { }	9.00	9.00	N/A	9.00	106,300	16,900	N/A	2-5/8"	30	134.3	38.5	40.5	905
SM*27A-1155[ ] { }	9.00	9.00	N/A	9.00	115,500	16,100	N/A	2-5/8"	30	134.3	38.5	40.5	960
SM*24A-1038[ ] { }	9.00	9.00	N/A	9.00	103,800	18,400	N/A	2-5/8"	36	134.3	38.5	40.5	858
SM*26A-1192[ ] { }	9.00	9.00	N/A	9.00	119,200	16,800	N/A	2-5/8"	36	134.3	38.5	40.5	915
SM*27A-1296[ ] { }	9.00	9.00	9.00	9.00	129,600	15,900	N/A	2-5/8"	36	134.3	38.5	40.5	975
SM*34A-1123[ ] { }	N/A	9.00	N/A	9.00	112,300	28,600	N/A	2-5/8"	33	134.3	38.5	51.0	960
SM*36A-1289[ ] { }	N/A	9.00	N/A	9.00	128,900	24,900	N/A	2-5/8"	33	134.3	38.5	51.0	1,070
SM*37A-1402[ ] { }	N/A	9.00	N/A	9.00	140,200	24,700	N/A	2-5/8"	33	134.3	38.5	51.0	1,090
SM*34A-1243[ ] { }	N/A	9.00	N/A	9.00	124,300	28,000	N/A	2-5/8"	40	134.3	38.5	51.0	1,034
SM*36A-1498[ ] { }	9.00	9.00	N/A	9.00	149,800	24,600	N/A	2-5/8"	40	134.3	38.5	51.0	1,156
SM*37A-1628[ ] { }	9.00	9.00	N/A	9.00	162,800	23,700	N/A	2-5/8"	40	134.3	38.5	51.0	1,175
SM*34A-1463[ ] { }	9.00	9.00	N/A	9.00	146,300	27,400	N/A	2-5/8"	48	134.3	38.5	51.0	1,100
SM*36A-1678[ ] { }	9.00	9.00	N/A	9.00	167,800	24,400	N/A	2-5/8"	48	134.3	38.5	51.0	1,235
SM*37A-1824[ ] { }	9.00	9.00	N/A	9.00	182,400	23,500	N/A	2-5/8"	48	134.3	38.5	51.0	1,255
SM*44A-1532[ ] { }	N/A	9.00	N/A	9.00	153,200	33,900	N/A	2-5/8"	42	173.0	38.5	52.5	1,280
SM*46A-1846[ ] { }	N/A	9.00	N/A	9.00	184,600	33,200	N/A	2-5/8"	42	173.0	38.5	52.5	1,430
SM*47A-1920[ ] { }	9.00	9.00	N/A	9.00	192,000	32,930	N/A	2-5/8"	42	173.0	38.5	52.5	1,455
SM*44A-1829[ ] { }	N/A	9.00	N/A	9.00	182,900	33,400	N/A	2-5/8"	52	173.0	38.5	52.5	1,380
SM*46A-2204[ ] { }	9.00	9.00	N/A	9.00	220,400	32,800	N/A	2-5/8"	52	173.0	38.5	52.5	1,540
SM*47A-2281[ ] { }	9.00	9.00	N/A	9.00	228,100	31,600	N/A	2-5/8"	52	173.0	38.5	52.5	1,565
SM*44A-2015[ ] { }	9.00	9.00	N/A	9.00	201,500	33,000	N/A	2-5/8"	62	173.0	38.5	52.5	1,470
SM*46A-2428[ ] { }	9.00	9.00	N/A	9.00	242,800	32,530	N/A	2-5/8"	62	173.0	38.5	52.5	1,645
SM*47A-2581[ ] { }	9.00	9.00	9.00	9.00	258,100	31,330	N/A	2-5/8"	62	173.0	38.5	52.5	1,670

\* For motor code and refrigerant, use "D" when AWEF rating is shown and "A" for non-regulated applications or where AWEF is N/A. Include fan motor heat of 4000 BTU/H per fan for SM and 6600 BTU/H per fan for SV models in room load calculations. De-rate capacity 12% for 50 Hertz operation with 3 phase motors only. [ ] Location for the refrigerant letter code. { } 3 phase motor C is standard for non-regulated applications, include "V" for Variable Speed EC control or "D" when Dual Speed control of the variable speed motor will be from a fixed 10 V signal.

\*\* Consult I/O manual for complete refrigerant listing.

#### EXAMPLE FULL MODEL:

SMA36A-1498TCK is non-regulated application with R-448A, three phase motors and 208/3/60 power.

#### Key Point -

Krack evaporator capacities shown are with **midpoint** evaporating temperature to offer a consistent capacity for selection when using different refrigerants and match other Krack and Hussmann equipment.

# SM/SV Series Unit Coolers

## Air Defrost High Profile

AIR DEFROST											
MODEL	COOLER AWEF BY REFRIGERANT AND MOTOR*		CAPACITY (BTU/H) @ 10° F TD +25° F EVAP	AIR FLOW (CFM)	REFRIGERATION CONNECTIONS		REF CHARGE (LB)	DIMENSIONS (IN)			SHIP WGT (LB)
	H - CO <sub>2</sub> (high pressure)				H - CO <sub>2</sub> (high pressure)			L	W	H	
	{D}ual Speed	{V}ariable Speed			LIQ	SUCT					
SM*14A-0314[ ][ ]	N/A	N/A	31,400	9,860	1/2"	7/8"	10	77.0	38.5	40.5	455
SM*16A-0378[ ][ ]	N/A	N/A	37,800	8,980	1/2"	7/8"	10	77.0	38.5	40.5	490
SM*17A-0410[ ][ ]	N/A	N/A	41,000	8,550	1/2"	7/8"	10	77.0	38.5	40.5	510
SM*14A-0403[ ][ ]	N/A	N/A	40,300	9,690	1/2"	7/8"	13	77.0	38.5	40.5	490
SM*16A-0463[ ][ ]	N/A	N/A	46,300	8,810	1/2"	7/8"	13	77.0	38.5	40.5	530
SM*17A-0503[ ][ ]	N/A	N/A	50,300	8,390	1/2"	7/8"	13	77.0	38.5	40.5	550
SM*14A-0469[ ][ ]	N/A	N/A	46,900	9,510	1/2"	7/8"	16	77.0	38.5	40.5	525
SM*16A-0538[ ][ ]	N/A	N/A	53,800	8,480	1/2"	7/8"	16	77.0	38.5	40.5	570
SM*17A-0585[ ][ ]	N/A	N/A	58,500	8,100	1/2"	7/8"	16	77.0	38.5	40.5	590
SM*14A-0526[ ][ ]	N/A	N/A	52,600	9,330	1/2"	7/8"	19	77.0	38.5	40.5	574
SM*16A-0604[ ][ ]	N/A	N/A	60,400	8,400	1/2"	7/8"	19	77.0	38.5	40.5	620
SM*17A-0657[ ][ ]	N/A	N/A	65,700	8,000	1/2"	7/8"	19	77.0	38.5	40.5	640
SM*24A-0619[ ][ ]	N/A	N/A	61,900	19,700	5/8"	7/8"	18	134.3	38.5	40.5	914
SM*26A-0746[ ][ ]	N/A	N/A	74,600	17,900	5/8"	7/8"	18	134.3	38.5	40.5	969
SM*27A-0811[ ][ ]	N/A	N/A	81,100	17,100	5/8"	7/8"	18	134.3	38.5	40.5	1,024
SM*24A-0797[ ][ ]	N/A	N/A	79,700	19,380	5/8"	7/8"	24	134.3	38.5	40.5	948
SM*26A-0915[ ][ ]	N/A	N/A	91,500	17,600	5/8"	7/8"	24	134.3	38.5	40.5	1,007
SM*27A-0995[ ][ ]	N/A	N/A	99,500	16,800	5/8"	7/8"	24	134.3	38.5	40.5	1,062
SM*24A-0882[ ][ ]	N/A	N/A	88,200	18,890	5/8"	7/8"	30	134.3	38.5	40.5	985
SM*26A-1063[ ][ ]	N/A	N/A	106,300	16,900	5/8"	7/8"	30	134.3	38.5	40.5	1,045
SM*27A-1155[ ][ ]	N/A	N/A	115,500	16,100	5/8"	7/8"	30	134.3	38.5	40.5	1,100
SM*24A-1038[ ][ ]	N/A	N/A	103,800	18,400	5/8"	7/8"	36	134.3	38.5	40.5	1,026
SM*26A-1192[ ][ ]	N/A	N/A	119,200	16,800	5/8"	7/8"	36	134.3	38.5	40.5	1,083
SM*27A-1296[ ][ ]	N/A	N/A	129,600	15,900	5/8"	7/8"	36	134.3	38.5	40.5	1,143
SM*34A-1123[ ][ ]	N/A	N/A	112,300	28,600	7/8"	1-1/8"	33	134.3	38.5	51.0	1,110
SM*36A-1289[ ][ ]	N/A	N/A	128,900	24,900	7/8"	1-1/8"	33	134.3	38.5	51.0	1,220
SM*37A-1402[ ][ ]	N/A	N/A	140,200	24,700	7/8"	1-1/8"	33	134.3	38.5	51.0	1,240
SM*34A-1243[ ][ ]	N/A	N/A	124,300	28,000	7/8"	1-1/8"	40	134.3	38.5	51.0	1,221
SM*36A-1498[ ][ ]	N/A	N/A	149,800	24,600	7/8"	1-1/8"	40	134.3	38.5	51.0	1,343
SM*37A-1628[ ][ ]	N/A	N/A	162,800	23,700	7/8"	1-1/8"	40	134.3	38.5	51.0	1,362
SM*34A-1463[ ][ ]	N/A	N/A	146,300	27,400	7/8"	1-1/8"	48	134.3	38.5	51.0	1,324
SM*36A-1678[ ][ ]	N/A	N/A	167,800	24,400	7/8"	1-1/8"	48	134.3	38.5	51.0	1,459
SM*37A-1824[ ][ ]	N/A	N/A	182,400	23,500	7/8"	1-1/8"	48	134.3	38.5	51.0	1,479
SM*44A-1532[ ][ ]	N/A	N/A	153,200	33,900	7/8"	1-1/8"	42	173.0	38.5	52.5	1,477
SM*46A-1846[ ][ ]	N/A	N/A	184,600	33,200	7/8"	1-1/8"	42	173.0	38.5	52.5	1,627
SM*47A-1920[ ][ ]	N/A	N/A	192,000	32,930	7/8"	1-1/8"	42	173.0	38.5	52.5	1,652
SM*44A-1829[ ][ ]	N/A	N/A	182,900	33,400	7/8"	1-1/8"	52	173.0	38.5	52.5	1,626
SM*46A-2204[ ][ ]	N/A	N/A	220,400	32,800	7/8"	1-1/8"	52	173.0	38.5	52.5	1,786
SM*47A-2281[ ][ ]	N/A	N/A	228,100	31,600	7/8"	1-1/8"	52	173.0	38.5	52.5	1,811
SM*44A-2015[ ][ ]	N/A	N/A	201,500	33,000	7/8"	1-1/8"	62	173.0	38.5	52.5	1,765
SM*46A-2428[ ][ ]	N/A	N/A	242,800	32,530	7/8"	1-1/8"	62	173.0	38.5	52.5	1,940
SM*47A-2581[ ][ ]	N/A	N/A	258,100	31,330	7/8"	1-1/8"	62	173.0	38.5	52.5	1,965

\* For motor code and refrigerant, use "D" when AWEF rating is shown and "A" for non-regulated applications or where AWEF is N/A. Include fan motor heat of 4000 BTU/H per fan for SM and 6600 BTU/H per fan for SV models in room load calculations. De-rate capacity 12% for 50 Hertz operation with 3 phase motors only. [ ] Location for the refrigerant letter code. { } 3 phase motor C is standard for non-regulated applications, include "V" for Variable Speed EC control or "D" when Dual Speed control of the variable speed motor will be from a fixed 10 V signal.

### EXAMPLE FULL MODEL:

SMA36A-1498TCK is non-regulated application with R-448A, three phase motors and 208/3/60 power.



Crack evaporator capacities shown are with **midpoint** evaporating temperature to offer a consistent capacity for selection when using different refrigerants and match other Crack and Hussmann equipment.

# SM/SV Series Unit Coolers

## Electric Defrost High Profile

### ELECTRIC DEFROST

SM MODEL	AWEF BY REFRIGERANT, MOTOR, and APPLICATION								CAPACITY (BTU/H) @ 10° F TD -20° F EVAP	CAPACITY (BTU/H) @ 10° F TD +20° F EVAP	AIR FLOW (CFM)	REFRIGERATION CONNECTIONS		REF CHARGE (LBS)	DIMENSIONS (IN)			SHIP WGT (LBS)
	[G] STOCK UNIT**, [Q] R-407A, [F] R-407F, [T] R-448A, [R] R-449A				[N] STOCK UNIT***, [S] R-404A, [P] R-507A							LIQ	SUCT		L	W	H	
	{D}ual Speed		{V}ariable Speed		{D}ual Speed		{V}ariable Speed											
	Freezer	Cooler	Freezer	Cooler	Freezer	Cooler	Freezer	Cooler										
SM*14E-0384[ ] { }	4.15	N/A	4.15	9.00	N/A	N/A	4.15	9.00	38,400	40,300	9,690	N/A	1-5/8"	13	77.00	38.50	40.50	440
SM*15E-0426[ ] { }	4.15	9.00	4.15	9.00	N/A	N/A	4.15	9.00	42,600	44,700	6,250	N/A	1-5/8"	13	77.00	38.50	40.50	450
SM*16E-0440[ ] { }	4.15	9.00	4.15	9.00	N/A	N/A	4.15	9.00	44,400	46,300	8,810	N/A	1-5/8"	13	77.00	38.50	40.50	470
SM*14E-0501[ ] { }	4.15	9.00	4.15	9.00	N/A	N/A	4.15	9.00	50,100	52,600	9,330	N/A	2-1/8"	19	77.00	38.50	40.50	495
SM*15E-0556[ ] { }	4.15	9.00	4.15	9.00	N/A	N/A	4.15	9.00	55,600	58,400	8,900	N/A	2-1/8"	19	77.00	38.50	40.50	505
SM*16E-0574[ ] { }	4.15	9.00	4.15	9.00	N/A	N/A	4.15	9.00	57,400	60,400	8,400	N/A	2-1/8"	19	77.00	38.50	40.50	530
SM*24E-0759[ ] { }	4.15	N/A	4.15	9.00	N/A	N/A	4.15	9.00	75,900	79,700	19,380	N/A	2-1/8"	24	134.30	38.50	40.50	836
SM*25E-0842[ ] { }	4.15	9.00	4.15	9.00	N/A	N/A	4.15	9.00	84,200	88,400	18,500	N/A	2-1/8"	24	134.30	38.50	40.50	874
SM*26E-0869[ ] { }	4.15	9.00	4.15	9.00	N/A	N/A	4.15	9.00	86,900	91,500	17,600	N/A	2-1/8"	24	134.30	38.50	40.50	912
SM*24E-0989[ ] { }	4.15	9.00	4.15	9.00	N/A	N/A	4.15	9.00	98,900	103,800	18,400	N/A	2-5/8"	36	134.30	38.50	40.50	860
SM*25E-1097[ ] { }	4.15	9.00	4.15	9.00	N/A	N/A	4.15	9.00	109,700	115,200	17,600	N/A	2-5/8"	36	134.30	38.50	40.50	900
SM*26E-1132[ ] { }	4.15	9.00	4.15	9.00	N/A	N/A	4.15	9.00	113,200	119,200	16,800	N/A	2-5/8"	36	134.30	38.50	40.50	920
SM*34E-1070[ ] { }	4.15	N/A	4.15	9.00	N/A	N/A	4.15	9.00	107,000	112,300	28,600	N/A	2-5/8"	33	134.30	38.50	51.00	1,030
SM*35E-1186[ ] { }	4.15	9.00	4.15	9.00	N/A	N/A	4.15	9.00	118,600	124,500	27,300	N/A	2-5/8"	33	134.30	38.50	51.00	1,050
SM*36E-1225[ ] { }	4.15	N/A	4.15	9.00	N/A	N/A	4.15	9.00	122,500	128,900	24,900	N/A	2-5/8"	33	134.30	38.50	51.00	1,060
SM*34E-1393[ ] { }	4.15	9.00	4.15	9.00	N/A	N/A	4.15	9.00	139,300	146,300	27,400	N/A	2-5/8"	48	134.30	38.50	51.00	1,195
SM*35E-1544[ ] { }	4.15	9.00	4.15	9.00	N/A	N/A	4.15	9.00	154,400	162,100	26,100	N/A	2-5/8"	48	134.30	38.50	51.00	1,215
SM*36E-1594[ ] { }	4.15	9.00	4.15	9.00	N/A	N/A	4.15	9.00	159,400	167,800	25,800	N/A	2-5/8"	48	134.30	38.50	51.00	1,240
SM*44E-1465[ ] { }	4.15	9.00	4.15	9.00	N/A	N/A	4.15	9.00	146,500	167,000	38,130	N/A	2-5/8"	47	173.00	38.50	52.50	1,370
SM*45E-1523[ ] { }	4.15	9.00	4.15	9.00	N/A	N/A	4.15	9.00	152,300	173,600	36,400	N/A	2-5/8"	47	173.00	38.50	52.50	1,340
SM*46E-1754[ ] { }	4.15	N/A	4.15	9.00	N/A	N/A	4.15	9.00	175,400	184,600	33,200	N/A	2-5/8"	47	173.00	38.50	52.50	1,400
¥ SM*44E-1769[ ] { }	4.15	9.00	4.15	9.00	N/A	N/A	4.15	9.00	176,900	201,800	36,530	N/A	(2) 2-1/8"	67	173.00	38.50	52.50	1,469
¥ SM*45E-1985[ ] { }	4.15	9.00	4.15	9.00	N/A	N/A	4.15	9.00	198,500	226,300	34,800	N/A	(2) 2-1/8"	67	173.00	38.50	52.50	1,540
¥ SM*46E-2307[ ] { }	4.15	9.00	4.15	9.00	N/A	N/A	4.15	9.00	230,700	242,800	32,530	N/A	(2) 2-1/8"	67	173.00	38.50	52.50	1,600

\* For motor code and refrigerant, use "D" when AWEF rating is shown and "A" for non-regulated applications or where AWEF is N/A. Include fan motor heat of 4000 BTU/H per fan in room load calculations. De-rate capacity 12% for 50 Hertz operation with 3 phase motors only. **Four fan SM/SV models for low temperature requires two expansion valves.** [ ] Location for the refrigerant letter code. { } 3 phase motor C is standard for non-regulated applications, include "V" for Variable Speed EC control or "D" when Dual Speed control of the variable speed motor will be from a fixed 10 V signal.

\*\* G Stock Units are for glide refrigerants only (consult I/O manual for complete refrigerant listing).

\*\*\* N Stock Units are for non-glide or glide refrigerants (consult I/O manual for complete refrigerant listing).

¥ Unit requires two (2) expansion valves. Face split is included in the base model price. Face split is only required for 4-fan, 6-row low temp applications.

#### EXAMPLE FULL MODELS:

SMD36E-1225SVK is DOE / NRCan with R-404A, variable speed motors and 208/3/60 power.

#### Key Point -

Krack evaporator capacities shown are with **midpoint** evaporating temperature to offer a consistent capacity for selection when using different refrigerants and match other Krack and Hussmann equipment.

# SM/SV Series Unit Coolers

## Electric Defrost High Profile

\* For motor code and refrigerant, use "D" when AWEF rating is shown and "A" for non-regulated applications or where AWEF is N/A. Include fan motor heat of 4000 BTU/H per fan in room load calculations. De-rate capacity 12% for 50 Hertz operation with 3 phase motors only. Four fan SM/SV models for low temperature requires two expansion valves. [ ] Location for the refrigerant letter code. { } 3 phase motor C is standard for non-regulated applications, include "V" for Variable Speed EC control or "D" when Dual Speed control of the variable speed motor will be from a fixed 10 V signal.

EXAMPLE FULL MODEL:  
SMD36E-1225SVK is DOE / NRCan with R-404A, variable speed motors and 208/3/60 power.

ELECTRIC DEFROST														
SM MODEL	AWEF BY REFRIGERANT, MOTOR, and APPLICATION				CAPACITY (BTU/H) @ 10° F TD -20° F EVAP	CAPACITY (BTU/H) @ 10° F TD +20° F EVAP	AIR FLOW (CFM)	REFRIGERATION CONNECTIONS		REF CHARGE (LB)	DIMENSIONS (IN)			SHIP WGT (LB)
	H - CO <sub>2</sub> (high pressure)							H - CO <sub>2</sub> (high pressure)			L	W	H	
	{D}ual Speed		{V}ariable Speed					LIQ	SUCT					
	Freezer	Cooler	Freezer	Cooler										
SM*14E-0384[ ] { }	N/A	N/A	N/A	N/A	38,400	40,300	9,690	1/2"	7/8"	13	77.00	38.50	40.50	500
SM*15E-0426[ ] { }	N/A	N/A	N/A	N/A	42,600	44,700	6,250	1/2"	7/8"	13	77.00	38.50	40.50	510
SM*16E-0440[ ] { }	N/A	N/A	N/A	N/A	44,400	46,300	8,810	1/2"	7/8"	13	77.00	38.50	40.50	530
SM*14E-0501[ ] { }	N/A	N/A	N/A	N/A	50,100	52,600	9,330	1/2"	7/8"	19	77.00	38.50	40.50	585
SM*15E-0556[ ] { }	N/A	N/A	N/A	N/A	55,600	58,400	8,900	1/2"	7/8"	19	77.00	38.50	40.50	595
SM*16E-0574[ ] { }	N/A	N/A	N/A	N/A	57,400	60,400	8,400	1/2"	7/8"	19	77.00	38.50	40.50	620
SM*24E-0759[ ] { }	N/A	N/A	N/A	N/A	75,900	79,700	19,380	5/8"	1-1/8"	24	134.30	38.50	40.50	948
SM*25E-0842[ ] { }	N/A	N/A	N/A	N/A	84,200	88,400	18,500	5/8"	1-1/8"	24	134.30	38.50	40.50	986
SM*26E-0869[ ] { }	N/A	N/A	N/A	N/A	86,900	91,500	17,600	5/8"	1-1/8"	24	134.30	38.50	40.50	1,024
SM*24E-0989[ ] { }	N/A	N/A	N/A	N/A	98,900	103,800	18,400	5/8"	1-1/8"	36	134.30	38.50	40.50	1,028
SM*25E-1097[ ] { }	N/A	N/A	N/A	N/A	109,700	115,200	17,600	5/8"	1-1/8"	36	134.30	38.50	40.50	1,068
SM*26E-1132[ ] { }	N/A	N/A	N/A	N/A	113,200	119,200	16,800	5/8"	1-1/8"	36	134.30	38.50	40.50	1,088
SM*34E-1070[ ] { }	N/A	N/A	N/A	N/A	107,000	112,300	28,600	7/8"	1-1/8"	33	134.30	38.50	51.00	1,180
SM*35E-1186[ ] { }	N/A	N/A	N/A	N/A	118,600	124,500	27,300	7/8"	1-1/8"	33	134.30	38.50	51.00	1,200
SM*36E-1225[ ] { }	N/A	N/A	N/A	N/A	122,500	128,900	24,900	7/8"	1-1/8"	33	134.30	38.50	51.00	1,210
SM*34E-1393[ ] { }	N/A	N/A	N/A	N/A	139,300	146,300	27,400	7/8"	1-1/8"	48	134.30	38.50	51.00	1,419
SM*35E-1544[ ] { }	N/A	N/A	N/A	N/A	154,400	162,100	26,100	7/8"	1-1/8"	48	134.30	38.50	51.00	1,439
SM*36E-1594[ ] { }	N/A	N/A	N/A	N/A	159,400	167,800	25,800	7/8"	1-1/8"	48	134.30	38.50	51.00	1,464
SM*44E-1465[ ] { }	N/A	N/A	N/A	N/A	146,500	167,000	38,130	7/8"	1-3/8"	47	173.00	38.50	52.50	1,567
SM*45E-1523[ ] { }	N/A	N/A	N/A	N/A	152,300	173,600	36,400	7/8"	1-3/8"	47	173.00	38.50	52.50	1,537
SM*46E-1754[ ] { }	N/A	N/A	N/A	N/A	175,400	184,600	33,200	7/8"	1-3/8"	47	173.00	38.50	52.50	1,597
SM*44E-1769[ ] { }	N/A	N/A	N/A	N/A	176,900	201,800	36,530	7/8"	1-3/8"	67	173.00	38.50	52.50	1,764
SM*45E-1985[ ] { }	N/A	N/A	N/A	N/A	198,500	226,300	34,800	7/8"	1-3/8"	67	173.00	38.50	52.50	1,835
SM*46E-2307[ ] { }	N/A	N/A	N/A	N/A	230,700	242,800	32,530	7/8"	1-3/8"	67	173.00	38.50	52.50	1,895

### Key Point -

Krack evaporator capacities shown are with **midpoint** evaporating temperature to offer a consistent capacity for selection when using different refrigerants and match other Krack and Hussmann equipment.

# SM/SV Series Unit Coolers

## Electric Defrost High Profile

### ELECTRIC DEFROST

SV MODEL	FREEZER AWEF BY REFRIGERANT and MOTOR				CAPACITY (BTU/H) @ 10° F TD -20° F EVAP	CAPACITY (BTU/H) @ 10° F TD +20° F EVAP	AIR FLOW (CFM)	REFRIGERATION CONNECTIONS		REF CHARGE (LBS)	DIMENSIONS (IN)			SHIP WGT (LBS)
	[G] STOCK UNIT**, [Q] R-407A, [F] R-407F, [T] R-448A, [R] R-449A		[N] STOCK UNIT***, [S] R-404A, [P] R-507A					LIQ	SUCT		L	W	H	
	{D}ual Speed	{V}variable Speed	{D}ual Speed	{V}variable Speed										
SV*14E-0422[ ]C	N/A	4.15	N/A	4.15	42,200	-	11,250	N/A	2-1/8"	13	77.00	38.50	40.50	440
SV*15E-0468[ ]C	N/A	4.15	N/A	4.15	46,800	-	11,125	N/A	2-1/8"	13	77.00	38.50	40.50	450
SV*16E-0664[ ]C	N/A	4.15	N/A	4.15	66,400	-	11,000	N/A	2-1/8"	13	77.00	38.50	40.50	530
SV*14E-0950[ ]C	N/A	4.15	N/A	4.15	55,000	-	11,250	N/A	2-1/8"	19	77.00	38.50	40.50	495
SV*15E-0611[ ]C	N/A	4.15	N/A	4.15	61,100	-	11,125	N/A	2-1/8"	19	77.00	38.50	40.50	505
SV*16E-0684[ ]C	N/A	4.15	N/A	4.15	68,400	-	11,000	N/A	2-1/8"	19	77.00	38.50	40.50	540
SV*24E-0834[ ]C	N/A	4.15	N/A	4.15	83,400	-	24,225	N/A	2-1/8"	24	134.30	38.50	40.50	836
SV*25E-0926[ ]C	N/A	4.15	N/A	4.15	92,600	-	23,125	N/A	2-1/8"	24	134.30	38.50	40.50	874
SV*26E-1005[ ]C	N/A	4.15	N/A	4.15	100,500	-	22,800	N/A	2-1/8"	24	134.30	38.50	40.50	912
SV*24E-1088[ ]C	N/A	4.15	N/A	4.15	108,800	-	23,000	N/A	2-1/8"	36	134.30	38.50	40.50	860
SV*25E-1206[ ]C	N/A	4.15	N/A	4.15	120,600	-	22,000	N/A	2-1/8"	36	134.30	38.50	40.50	900
SV*26E-1311[ ]C	N/A	4.15	N/A	4.15	131,100	-	21,550	N/A	2-1/8"	36	134.30	38.50	40.50	920
SV*34E-1177[ ]C	N/A	4.15	N/A	4.15	117,700	-	35,750	N/A	2-5/8"	33	134.30	38.50	51.00	1,030
SV*35E-1304[ ]C	N/A	4.15	N/A	4.15	130,400	-	34,125	N/A	2-5/8"	33	134.30	38.50	51.00	1,050
SV*36E-1418[ ]C	N/A	4.15	N/A	4.15	141,800	-	33,400	N/A	2-5/8"	33	134.30	38.50	51.00	1,060
SV*34E-1530[ ]C	N/A	4.15	N/A	4.15	153,000	-	34,250	N/A	2-5/8"	48	134.30	38.50	51.00	1,195
SV*35E-1698[ ]C	N/A	4.15	N/A	4.15	169,800	-	32,625	N/A	2-5/8"	48	134.30	38.50	51.00	1,215
SV*36E-1843[ ]C	N/A	4.15	N/A	4.15	184,300	-	32,000	N/A	2-5/8"	48	134.30	38.50	51.00	1,240
SV*44E-1699[ ]C	N/A	4.15	N/A	4.15	169,900	-	47,650	N/A	(2) 2-1/8"	47	173.00	38.50	52.50	1,370
SV*45E-1883[ ]C	N/A	4.15	N/A	4.15	188,300	-	45,500	N/A	(2) 2-1/8"	47	173.00	38.50	52.50	1,340
SV*46E-2047[ ]C	N/A	4.15	N/A	4.15	204,700	-	44,500	N/A	(2) 2-1/8"	47	173.00	38.50	52.50	1,400
¥ SV*44E-2052[ ]C	N/A	4.15	N/A	4.15	205,200	-	45,650	N/A	(2) 2-1/8"	67	173.00	38.50	52.50	1,469
¥ SV*45E-2274[ ]C	N/A	4.15	N/A	4.15	227,400	-	43,600	N/A	(2) 2-1/8"	67	173.00	38.50	52.50	1,540
¥ SV*46E-2472[ ]C	N/A	4.15	N/A	4.15	247,200	-	42,700	N/A	(2) 2-1/8"	67	173.00	38.50	52.50	1,600

\* For motor code and refrigerant, use "D" when AWEF rating is shown and "A" for non-regulated applications or where AWEF is N/A.  
**SV models are available for use in non-regulated applications.** 3 phase motors can be upgraded to Variable Speed EC motors for energy savings.  
 Include fan motor heat of 6600 BTU/H per fan in room load calculations. De-rate capacity 12% for 50 Hertz operation with 3 phase motors only.

**Four fan SM/SV models for low temperature requires two expansion valves.**  
 [ ] Location for the refrigerant letter code. { } 3 phase motor C is standard for non-regulated applications, include "V" for Variable Speed EC control or "D" when Dual Speed control of the variable speed motor will be from a fixed 10 V signal.

\*\* G Stock Units are for glide refrigerants only (consult I/O manual for complete refrigerant listing).

\*\*\* N Stock Units are for non-glide or glide refrigerants (consult I/O manual for complete refrigerant listing).

¥ Unit requires two (2) expansion valves. Face split is included in the base model price. Face split is only required for 4-fan, 6-row low temp applications.

#### EXAMPLE FULL MODELS:

SVA36E-1418QCK is for non-regulated applications with R-407A, 3 phase motors and 208/3/60 power.



Crack evaporator capacities shown are with **midpoint** evaporating temperature to offer a consistent capacity for selection when using different refrigerants and match other Crack and Hussmann equipment.

# SM/SV Series Unit Coolers

## Electric Defrost High Profile

\* For motor code and refrigerant, use "D" when AWEF rating is shown and "A" for non-regulated applications or where AWEF is N/A. SV models are available for use in non-regulated applications. 3 phase motors can be upgraded to Variable Speed EC motors for energy savings. Include fan motor heat of 6600 BTU/H per fan in room load calculations. De-rate capacity 12% for 50 Hertz operation with 3 phase motors only. **Four fan SM/SV models for low temperature requires two expansion valves.** [ ] Location for the refrigerant letter code. { } 3 phase motor C is standard for non-regulated applications, include "V" for Variable Speed EC controller "D" when Dual Speed control of the variable speed motor will be from a fixed 10 V signal.

EXAMPLE FULL MODEL:  
SMD36E-122SSVK is DOE / NRCan with R-404A, variable speed motors and 208/3/60 power.

ELECTRIC DEFROST													
SV MODEL	FREEZER AWEF BY REFRIGERANT and MOTOR		@ 10° F TD -20° F EVAP	@ 10° F TD +20° F EVAP	FLOW (CFM)	REFRIGERATION CONNECTIONS		REF CHARGE (LB)	DIMENSIONS (IN)			SHIP WGT (LB)	
	H - CO <sub>2</sub> (high pressure)					H - CO <sub>2</sub> (high pressure)			L	W	H		H - CO <sub>2</sub> (high)
	{D}ual Speed	{V}ariable Speed				LIQ	SUCT						
SV*14E-0422[ ]C	N/A	N/A	42,200	-	11,250	1/2"	7/8"	13	77.00	38.50	40.50	500	
SV*15E-0468[ ]C	N/A	N/A	46,800	-	11,125	1/2"	7/8"	13	77.00	38.50	40.50	510	
SV*16E-0664[ ]C	N/A	N/A	66,400	-	11,000	1/2"	7/8"	13	77.00	38.50	40.50	590	
SV*14E-0550[ ]C	N/A	N/A	55,000	-	11,250	1/2"	7/8"	19	77.00	38.50	40.50	585	
SV*15E-0611[ ]C	N/A	N/A	61,100	-	11,125	1/2"	7/8"	19	77.00	38.50	40.50	595	
SV*16E-0684[ ]C	N/A	N/A	68,400	-	11,000	1/2"	7/8"	19	77.00	38.50	40.50	630	
SV*24E-0834[ ]C	N/A	N/A	83,400	-	24,225	5/8"	1-3/8"	24	134.30	38.50	40.50	948	
SV*25E-0926[ ]C	N/A	N/A	92,600	-	23,125	5/8"	1-3/8"	24	134.30	38.50	40.50	986	
SV*26E-1005[ ]C	N/A	N/A	100,500	-	22,800	5/8"	1-3/8"	24	134.30	38.50	40.50	1,024	
SV*24E-1088[ ]C	N/A	N/A	108,800	-	23,000	5/8"	1-3/8"	36	134.30	38.50	40.50	1,028	
SV*25E-1206[ ]C	N/A	N/A	120,600	-	22,000	5/8"	1-3/8"	36	134.30	38.50	40.50	1,068	
SV*26E-1311[ ]C	N/A	N/A	131,100	-	21,550	5/8"	1-3/8"	36	134.30	38.50	40.50	1,088	
SV*34E-1177[ ]C	N/A	N/A	117,700	-	35,750	7/8"	1-3/8"	33	134.30	38.50	51.00	1,180	
SV*35E-1304[ ]C	N/A	N/A	130,400	-	34,125	7/8"	1-3/8"	33	134.30	38.50	51.00	1,200	
SV*36E-1418[ ]C	N/A	N/A	141,800	-	33,400	7/8"	1-3/8"	33	134.30	38.50	51.00	1,210	
SV*34E-1530[ ]C	N/A	N/A	153,000	-	34,250	7/8"	1-3/8"	48	134.30	38.50	51.00	1,419	
SV*35E-1698[ ]C	N/A	N/A	169,800	-	32,625	7/8"	1-3/8"	48	134.30	38.50	51.00	1,439	
SV*36E-1843[ ]C	N/A	N/A	184,300	-	32,000	7/8"	1-3/8"	48	134.30	38.50	51.00	1,464	
SV*44E-1699[ ]C	N/A	N/A	169,900	-	47,650	7/8"	1-3/8"	47	173.00	38.50	52.50	1,567	
SV*45E-1883[ ]C	N/A	N/A	188,300	-	45,500	7/8"	1-3/8"	47	173.00	38.50	52.50	1,537	
SV*46E-2047[ ]C	N/A	N/A	204,700	-	44,500	7/8"	1-3/8"	47	173.00	38.50	52.50	1,597	
SV*44E-2052[ ]C	N/A	N/A	205,200	-	45,650	7/8"	1-3/8"	67	173.00	38.50	52.50	1,764	
SV*45E-2274[ ]C	N/A	N/A	227,400	-	43,600	7/8"	1-3/8"	67	173.00	38.50	52.50	1,835	
SV*46E-2472[ ]C	N/A	N/A	247,200	-	42,700	7/8"	1-3/8"	67	173.00	38.50	52.50	1,895	

 Key Point -

Krack evaporator capacities shown are with **midpoint** evaporating temperature to offer a consistent capacity for selection when using different refrigerants and match other Krack and Hussmann equipment.

# SM/SV Series Unit Coolers

## Hot Gas Defrost High Profile

### GAS DEFOST

SM MODEL	AWEF BY REFRIGERANT, MOTOR, and APPLICATION								CAPACITY (BTU/H) @ 10° F TD -20° F EVAP	CAPACITY (BTU/H) @ 10° F TD +20° F EVAP	AIR FLOW (CFM)	REFRIGERATION CONNECTIONS		REF CHARGE (LBS)	DIMENSIONS (IN)			SHIP WGT (LBS)
	[G] STOCK UNIT**, [Q] R-407A, [F] R-407F, [T] R-448A, [R] R-449A				[N] STOCK UNIT**, [S] R-404A, [P] R-507A							DEFR GAS	SUCT		L	W	H	
	{D}ual Speed		{V}ariable Speed		{D}ual Speed		{V}ariable Speed											
	Freezer	Cooler	Freezer	Cooler	Freezer	Cooler	Freezer	Cooler										
SM*14(-)-0384[ JC	4.15	N/A	4.15	9.00	N/A	N/A	4.15	9.00	38,400	40,300	9,690	1/2"	1-5/8"	13	77.00	38.50	40.50	440
SM*15(-)-0426[ JC	4.15	9.00	4.15	9.00	N/A	N/A	4.15	9.00	42,600	44,700	6,250	1/2"	1-5/8"	13	77.00	38.50	40.50	450
SM*16(-)-0440[ JC	4.15	9.00	4.15	9.00	N/A	N/A	4.15	9.00	44,400	46,300	8,810	1/2"	1-5/8"	13	77.00	38.50	40.50	470
SM*14(-)-0501[ JC	4.15	9.00	4.15	9.00	N/A	N/A	4.15	9.00	50,100	52,600	9,330	7/8"	2-1/8"	19	77.00	38.50	40.50	495
SM*15(-)-0556[ JC	4.15	9.00	4.15	9.00	N/A	N/A	4.15	9.00	55,600	58,400	8,900	7/8"	2-1/8"	19	77.00	38.50	40.50	505
SM*16(-)-0574[ JC	4.15	9.00	4.15	9.00	N/A	N/A	4.15	9.00	57,400	60,400	8,400	7/8"	2-1/8"	19	77.00	38.50	40.50	530
SM*24(-)-0759[ JC	4.15	N/A	4.15	9.00	N/A	N/A	4.15	9.00	75,900	79,700	19,380	7/8"	2-1/8"	24	134.30	38.50	40.50	836
SM*25(-)-0842[ JC	4.15	9.00	4.15	9.00	N/A	N/A	4.15	9.00	84,200	88,400	18,500	7/8"	2-1/8"	24	134.30	38.50	40.50	874
SM*26(-)-0869[ JC	4.15	9.00	4.15	9.00	N/A	N/A	4.15	9.00	86,900	91,500	17,600	7/8"	2-1/8"	24	134.30	38.50	40.50	912
SM*24(-)-0989[ JC	4.15	9.00	4.15	9.00	N/A	N/A	4.15	9.00	98,900	103,800	18,400	7/8"	2-5/8"	36	134.30	38.50	40.50	860
SM*25(-)-1097[ JC	4.15	9.00	4.15	9.00	N/A	N/A	4.15	9.00	109,700	115,200	17,600	7/8"	2-5/8"	36	134.30	38.50	40.50	900
SM*26(-)-1132[ JC	4.15	9.00	4.15	9.00	N/A	N/A	4.15	9.00	113,200	119,200	16,800	7/8"	2-5/8"	36	134.30	38.50	40.50	920
SM*34(-)-1070[ JC	4.15	N/A	4.15	9.00	N/A	N/A	4.15	9.00	107,000	112,300	28,600	7/8"	2-5/8"	33	134.30	38.50	51.00	1,030
SM*35(-)-1186[ JC	4.15	9.00	4.15	9.00	N/A	N/A	4.15	9.00	118,600	124,500	27,300	7/8"	2-5/8"	33	134.30	38.50	51.00	1,050
SM*36(-)-1225[ JC	4.15	N/A	4.15	9.00	N/A	N/A	4.15	9.00	122,500	128,900	24,900	1-1/8"	2-5/8"	33	134.30	38.50	51.00	1,060
SM*34(-)-1393[ JC	4.15	9.00	4.15	9.00	N/A	N/A	4.15	9.00	139,300	146,300	27,400	1-1/8"	2-5/8"	48	134.30	38.50	51.00	1,195
SM*35(-)-1544[ JC	4.15	9.00	4.15	9.00	N/A	N/A	4.15	9.00	154,400	162,100	26,100	1-1/8"	2-5/8"	48	134.30	38.50	51.00	1,215
SM*36(-)-1594[ JC	4.15	9.00	4.15	9.00	N/A	N/A	4.15	9.00	159,400	167,800	25,800	1-1/8"	2-5/8"	48	134.30	38.50	51.00	1,240
SM*44(-)-1465[ JC	4.15	9.00	4.15	9.00	N/A	N/A	4.15	9.00	146,500	167,000	38,130	1-1/8"	2-5/8"	47	173.00	38.50	52.50	1,370
SM*45(-)-1523[ JC	4.15	9.00	4.15	9.00	N/A	N/A	4.15	9.00	152,300	173,600	36,400	1-1/8"	2-5/8"	47	173.00	38.50	52.50	1,340
SM*46(-)-1754[ JC	4.15	N/A	4.15	9.00	N/A	N/A	4.15	9.00	175,400	184,600	33,200	1-1/8"	2-5/8"	47	173.00	38.50	52.50	1,400
¥ SM*44(-)-1769[ JC	4.15	9.00	4.15	9.00	N/A	N/A	4.15	9.00	176,900	201,800	36,530	(2) 7/8"	(2) 2-1/8"	67	173.00	38.50	52.50	1,469
¥ SM*45(-)-1985[ JC	4.15	9.00	4.15	9.00	N/A	N/A	4.15	9.00	198,500	226,300	34,800	(2) 7/8"	(2) 2-1/8"	67	173.00	38.50	52.50	1,540
¥ SM*46(-)-2307[ JC	4.15	9.00	4.15	9.00	N/A	N/A	4.15	9.00	230,700	242,800	32,530	(2) 7/8"	(2) 2-1/8"	67	173.00	38.50	52.50	1,600

\* For motor code and refrigerant, use "D" when AWEF rating is shown and "A" for non-regulated applications or where AWEF is N/A.

[ ] Gas defrost type K, H, G, or P. See definition to the right. [ ] Location for the refrigerant letter code.

{ } Variable Speed EC motor is standard, include "V" for Variable Speed EC control or "D" when Dual Speed control from 10 V signal will be applied.

\*\* G Stock Units are for glide refrigerants only (consult I/O manual for complete refrigerant listing).

\*\*\* N Stock Units are for non-glide or glide refrigerants (consult I/O manual for complete refrigerant listing).

¥ Unit requires two (2) expansion valves. Face split is included in the base model price. Face split is only required for 4-fan, 6-row low temp applications.

#### EXAMPLE FULL MODEL:

MKD36P-3090DAA is for DOE / NRCan application with R-407A.

Dual Speed EC motor and includes the additional letters AA for 208 V single phase power.

#### Available Gas Defrost Types

(H) - HGE 3 Pipe Hot Gas with Electric Pan Heat. No defrost termination or fan delay.

(G) - HGG 3 Pipe Hot Gas with Gas Pan Heat. No defrost termination or fan delay.

(P) - KGE 2 Pipe Kool Gas with Electric Pan Heat.

(K) - KGG 2 Pipe Kool Gas with Gas Pan Heat.

#### Key Point -

Krack evaporator capacities shown are with **midpoint** evaporating temperature to offer a consistent capacity for selection when using different refrigerants and match other Krack and Hussmann equipment.

# SM/SV Series Unit Coolers

## Hot Gas Defrost High Profile

GAS DEFOST																
SM MODEL	AWEF BY REFRIGERANT, MOTOR, and APPLICATION				CAPACITY (BTU/H) @ 10° F TD -20° F EVAP	CAPACITY (BTU/H) @ 10° F TD +20° F EVAP	AIR FLOW (CFM)	REFRIGERATION CONNECTIONS		REF CHARGE (LB)	DIMENSIONS (IN)			SHIP WGT (LB) H - CO <sub>2</sub> (high)		
	H - CO <sub>2</sub> (high pressure)							H - CO <sub>2</sub> (high pressure)			GAS	SUCT	L		W	H
	{D}ual Speed		{V}ariable Speed													
	Freezer	Cooler	Freezer	Cooler												
SM*14(-)-0384[ ]C	N/A	N/A	N/A	N/A	38,400	40,300	9,690	1/2"	7/8"	13	77.00	38.50	40.50	500		
SM*15(-)-0426[ ]C	N/A	N/A	N/A	N/A	42,600	44,700	6,250	1/2"	7/8"	13	77.00	38.50	40.50	510		
SM*16(-)-0440[ ]C	N/A	N/A	N/A	N/A	44,400	46,300	8,810	1/2"	7/8"	13	77.00	38.50	40.50	530		
SM*14(-)-0501[ ]C	N/A	N/A	N/A	N/A	50,100	52,600	9,330	1/2"	7/8"	19	77.00	38.50	40.50	585		
SM*15(-)-0556[ ]C	N/A	N/A	N/A	N/A	55,600	58,400	8,900	1/2"	7/8"	19	77.00	38.50	40.50	595		
SM*16(-)-0574[ ]C	N/A	N/A	N/A	N/A	57,400	60,400	8,400	1/2"	7/8"	19	77.00	38.50	40.50	620		
SM*24(-)-0759[ ]C	N/A	N/A	N/A	N/A	75,900	79,700	19,380	5/8"	1-1/8"	24	134.30	38.50	40.50	948		
SM*25(-)-0842[ ]C	N/A	N/A	N/A	N/A	84,200	88,400	18,500	5/8"	1-1/8"	24	134.30	38.50	40.50	986		
SM*26(-)-0869[ ]C	N/A	N/A	N/A	N/A	86,900	91,500	17,600	5/8"	1-1/8"	24	134.30	38.50	40.50	1,024		
SM*24(-)-0989[ ]C	N/A	N/A	N/A	N/A	98,900	103,800	18,400	5/8"	1-1/8"	36	134.30	38.50	40.50	1,028		
SM*25(-)-1097[ ]C	N/A	N/A	N/A	N/A	109,700	115,200	17,600	5/8"	1-1/8"	36	134.30	38.50	40.50	1,068		
SM*26(-)-1132[ ]C	N/A	N/A	N/A	N/A	113,200	119,200	16,800	5/8"	1-1/8"	36	134.30	38.50	40.50	1,088		
SM*34(-)-1070[ ]C	N/A	N/A	N/A	N/A	107,000	112,300	28,600	7/8"	1-1/8"	33	134.30	38.50	51.00	1,180		
SM*35(-)-1186[ ]C	N/A	N/A	N/A	N/A	118,600	124,500	27,300	7/8"	1-1/8"	33	134.30	38.50	51.00	1,200		
SM*36(-)-1225[ ]C	N/A	N/A	N/A	N/A	122,500	128,900	24,900	7/8"	1-1/8"	33	134.30	38.50	51.00	1,210		
SM*34(-)-1393[ ]C	N/A	N/A	N/A	N/A	139,300	146,300	27,400	7/8"	1-1/8"	48	134.30	38.50	51.00	1,419		
SM*35(-)-1544[ ]C	N/A	N/A	N/A	N/A	154,400	162,100	26,100	7/8"	1-1/8"	48	134.30	38.50	51.00	1,439		
SM*36(-)-1594[ ]C	N/A	N/A	N/A	N/A	159,400	167,800	25,800	7/8"	1-1/8"	48	134.30	38.50	51.00	1,464		
SM*44(-)-1465[ ]C	N/A	N/A	N/A	N/A	146,500	167,000	38,130	7/8"	1-3/8"	47	173.00	38.50	52.50	1,567		
SM*45(-)-1523[ ]C	N/A	N/A	N/A	N/A	152,300	173,600	36,400	7/8"	1-3/8"	47	173.00	38.50	52.50	1,537		
SM*46(-)-1754[ ]C	N/A	N/A	N/A	N/A	175,400	184,600	33,200	7/8"	1-3/8"	47	173.00	38.50	52.50	1,597		
SM*44(-)-1769[ ]C	N/A	N/A	N/A	N/A	176,900	201,800	36,530	7/8"	1-3/8"	67	173.00	38.50	52.50	1,764		
SM*45(-)-1985[ ]C	N/A	N/A	N/A	N/A	198,500	226,300	34,800	7/8"	1-3/8"	67	173.00	38.50	52.50	1,835		
SM*46(-)-2307[ ]C	N/A	N/A	N/A	N/A	230,700	242,800	32,530	7/8"	1-3/8"	67	173.00	38.50	52.50	1,895		

\* For motor code and refrigerant, use "D" when AWEF rating is shown and "A" for non-regulated applications or where AWEF is N/A. ( ) Gas defrost type K, H, G, or P. See definition to the right.  
 [ ] Location for the refrigerant letter code. { } Variable Speed EC motor is standard, include "V" for Variable Speed EC control or "D" when Dual Speed control from 10 V signal will be applied.

### Example Full Model:

MKD36P-309QDAA is for DOE / NRCan application with R-407A, Dual Speed EC motor and includes the additional letters AA for 208 V single phase power.

### Available Gas Defrost Types

- (P) - KGE 2 Pipe Kool Gas with Electric Pan Heat.
- (K) - KGG 2 Pipe Kool Gas with Gas Pan Heat.

### Key Point -

Krack evaporator capacities shown are with **midpoint** evaporating temperature to offer a consistent capacity for selection when using different refrigerants and match other Krack and Hussmann equipment.

# SM/SV Series Unit Coolers

## Fan Motor Data

MOTOR OPTIONS														
SM MODEL	3 PHASE MOTORS										VARIABLE SPEED EC			
	208/3/60		380/3/50		380/3/60		460/3/60		575/3/60		208/3/60		460/3/60	
	AMPS	WATTS	AMPS	WATTS	AMPS	WATTS	AMPS	WATTS	AMPS	WATTS	AMPS	WATTS	AMPS	WATTS
1 FAN	4.8	1172	2.3	762	2.3	1172	2.4	1172	1.8	1172	5.4	1172	3.0	1172
2 FAN	9.6	2344	4.6	1524	4.6	2344	4.8	2344	3.6	2344	10.8	2344	6.0	2344
3 FAN	14.4	3516	6.9	2285	6.9	3516	7.2	3516	5.4	3516	16.2	3516	9.0	3516
4 FAN	19.2	4688	9.2	3047	9.2	4688	9.6	4688	7.2	4688	21.6	4688	12.0	4688

SV MODEL	3 PHASE MOTORS										VARIABLE SPEED EC			
	208/3/60		380/3/50		380/3/60		460/3/60		575/3/60		208/3/60		460/3/60	
	AMPS	WATTS	AMPS	WATTS	AMPS	WATTS	AMPS	WATTS	AMPS	WATTS	AMPS	WATTS	AMPS	WATTS
1 FAN	5.4	1935	2.1	1260	2.5	1935	2.5	1935	2.2	1935	5.4	1935	3.0	1935
2 FAN	10.8	3870	4.2	2520	5.0	3870	7.0	3870	4.4	3870	10.8	3870	6.0	3870
3 FAN	16.2	5805	6.3	3780	7.5	5805	10.5	5805	6.6	5805	16.2	5805	9.0	5805
4 FAN	21.6	7740	8.4	5040	10.0	7740	14.0	7740	8.8	7740	21.6	7740	12.0	7740

Variable Speed EC motors are motor codes "V" and "D" will use 0-10 V speed signal with 0 V or no signal full speed.  
Refer to complete Model Key on page 2.

### Key Point -

EC motors will operate variable speed with a 0-10 V signal or Dual Speed by providing a 10 V signal for minimum speed operation.  
Operation will be the same as a single speed motor without a control signal.

## Electric / Hot Gas Defrost Heater Data

ELECTRIC DEFROST										
MODEL	ELECTRIC DEFROST (E)									
	230/3/60		380/3/50-60		460/3/60		575/3/60			
	AMPS	KW	AMPS	KW	AMPS	KW	AMPS	KW	AMPS	KW
1 FAN	384, 426, 440, 501, 556, 574 422, 438, 550, 611, 664		34.7	13.8	19.8	13.0	17.3	13.8	13.9	13.8
2 FAN	759, 842, 869, 989, 1097, 1132 834, 926, 1005, 1088, 1206, 1311		1 @ 42.2 1 @ 21.9	1 @ 16.8 1 @ 8.7	36.6	24.1	32.0	25.5	25.6	25.5
3 FAN	1070, 1186, 1225, 1177, 1304, 1418 1393, 1544, 1594, 1530, 1698, 1843		1 @ 42.2 1 @ 32.5	1 @ 16.8 1 @ 12.9	43.0	28.3	37.4	29.7	29.9	29.7
4 FAN	1465, 1523, 1754, 1699, 1883, 2047 1769, 1985, 2307, 2052, 2274, 2472		2 @ 40.7 1 @ 14.3	2 @ 16.2 1 @ 5.7	1 @ 32.8 1 @ 22.3	1 @ 21.6 1 @ 14.7	47.8	38.1	38.3	38.1

HOT GAS DEFROST										
MODEL	PAN HEATER (H AND P)									
	230/3/60		380/3/50-60		460/3/60		575/3/60			
	AMPS	KW	AMPS	KW	AMPS	KW	AMPS	KW	AMPS	KW
1 FAN	384, 426, 440, 501, 556, 574		6.4	2.6	2.7	1.8	3.2	2.6	2.6	2.6
2 FAN	759, 842, 869, 989, 1097, 1132		11.3	4.5	4.6	3.0	5.6	4.5	4.5	4.5
3 FAN	1070, 1186, 1225, 1393, 1544, 1594		11.3	4.5	4.6	3.0	5.6	4.5	4.5	4.5
4 FAN	1465, 1523, 1754, 1769, 1985, 2307		14.3	5.7	5.9	3.9	7.2	5.7	5.7	5.7

Electrical information for electric defrost type "E".  
Electrical information for pan heaters on defrost type "P" and "H".  
Refer to complete Model Key on page 2.

# SM/SV Series Unit Coolers

## Dimensional Data

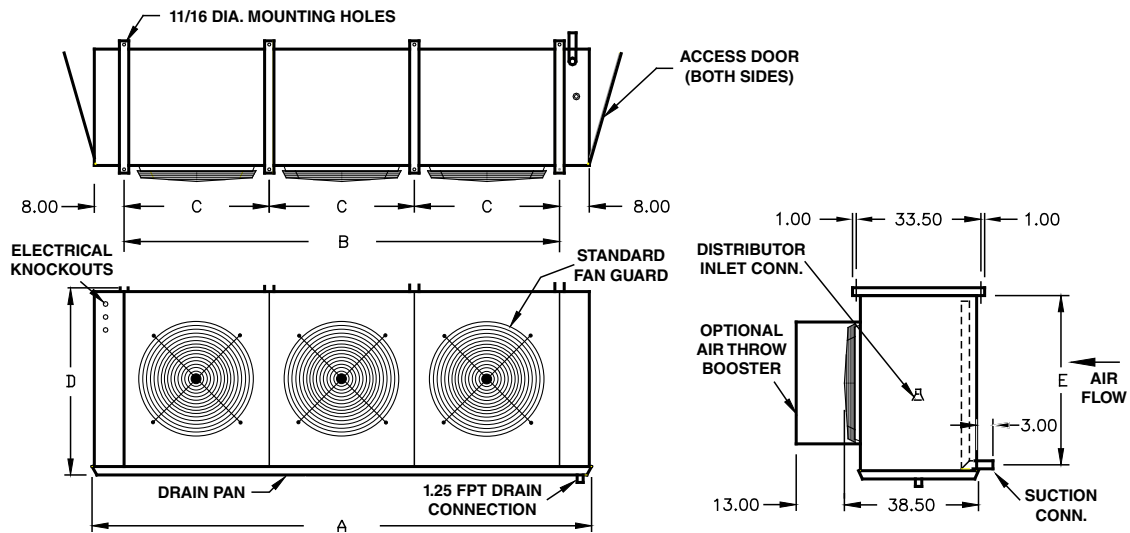

### UNIT DIMENSIONS

SIZE	A	B	C	D	E
1 FAN	77.00	60.00	1 @ 60.00	40.50	34.00
2 FAN	134.25	117.00	2 @ 58.50	40.50	34.00
3 FAN	134.25	117.00	3 @ 39.00	52.50	46.00
4 FAN	173.00	156.00	4 @ 39.00	52.50	46.00

Note: All dimensions in inches.

# SM/SV Series Unit Coolers

## Wiring Diagrams

### 3 Phase Motor Wiring - Motor Code C

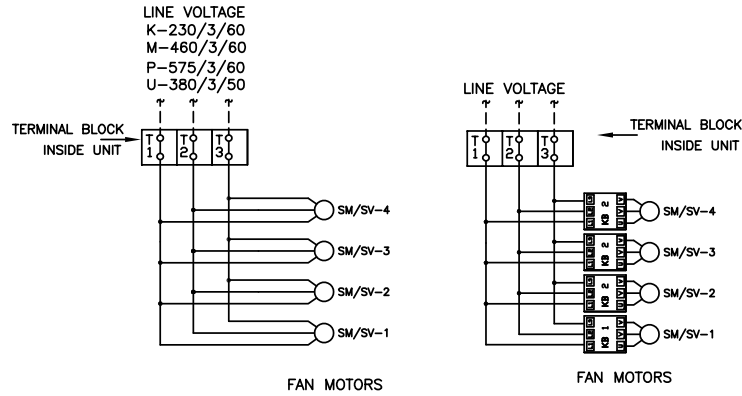

### Dual Speed Variable Speed EC Motor Wiring - Motor Code D

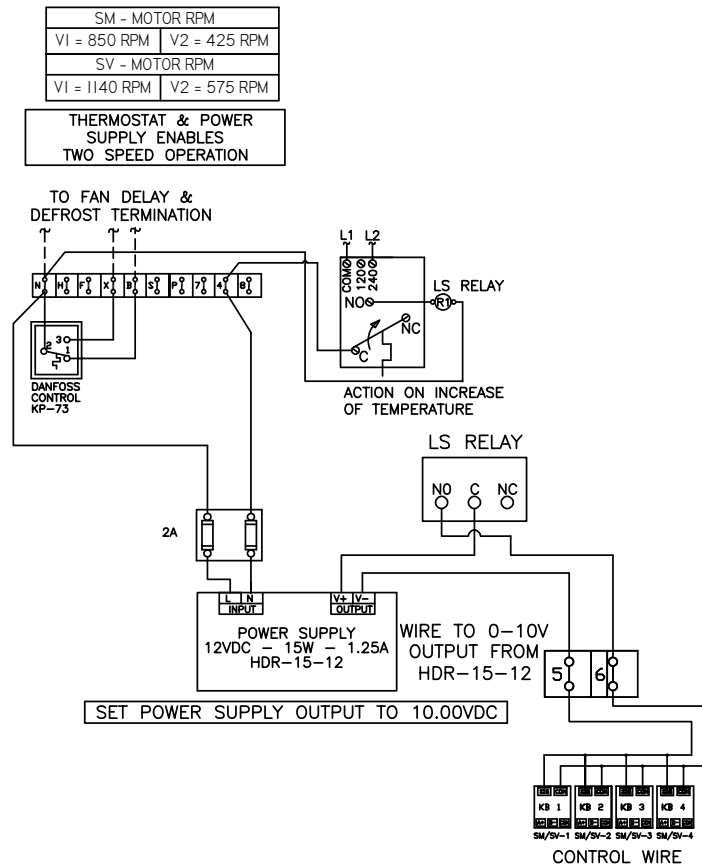

# SM/SV Series Unit Coolers

## Wiring Diagrams

### Variable Speed EC Motor Wiring - Motor Code V

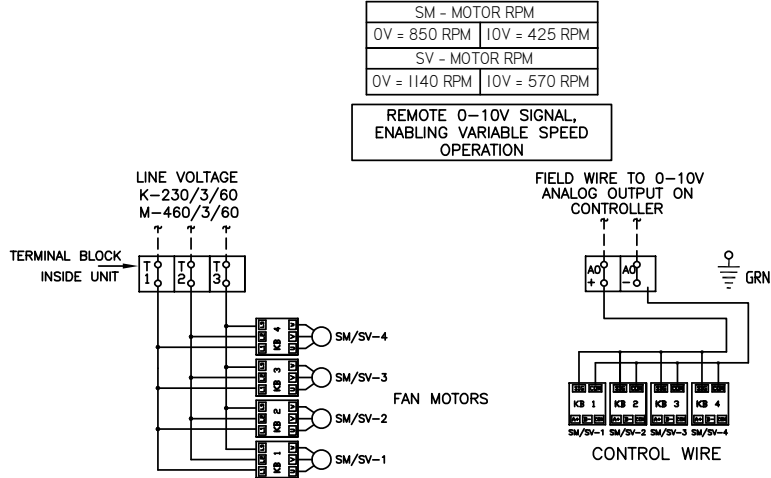

### Variable Speed EC Motor Wiring - Motor Code V Electric Defrost with System 450 Control

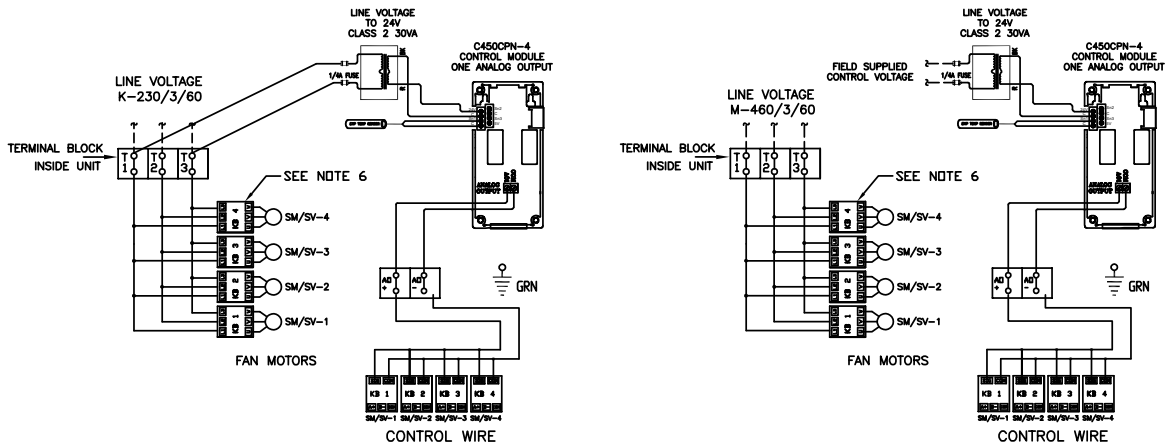

# SM/SV Series Unit Coolers

## Wiring Diagrams

### Heater Wiring

ELECTRICAL DEFROST UNIT (E)

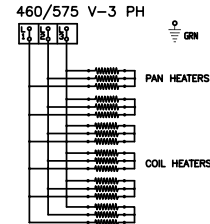
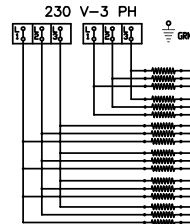
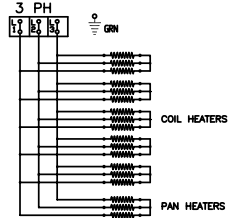

### Gas Defrost Setup

H and P Defrost Control Wiring -  
Gas Defrost with Electric Drain Pan Heater

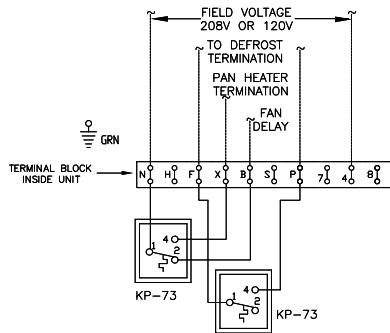

G and K Defrost Control Wiring -  
Gas Defrost with Gas Drain Pan Heater

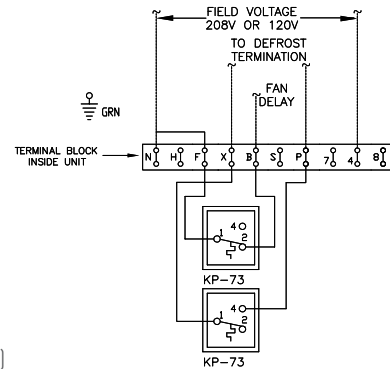

3 Pipe Hot Gas Defrost  
with Electric Defrost Drain Pan (H)

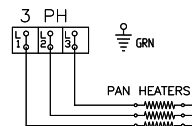







Use your QR reader to  
reference current document  
version on [www.krack.com](http://www.krack.com).



**Krack, a Hussmann Corporation brand**

For all customers inquiries,  
visit [www.krack.com](http://www.krack.com) or call 800.922.1919.

[www.krack.com](http://www.krack.com)  
[www.hussmann.com](http://www.hussmann.com)