

BTR Series

BETWEEN-THE-RAIL UNIT COOLERS

Technical Bulletin

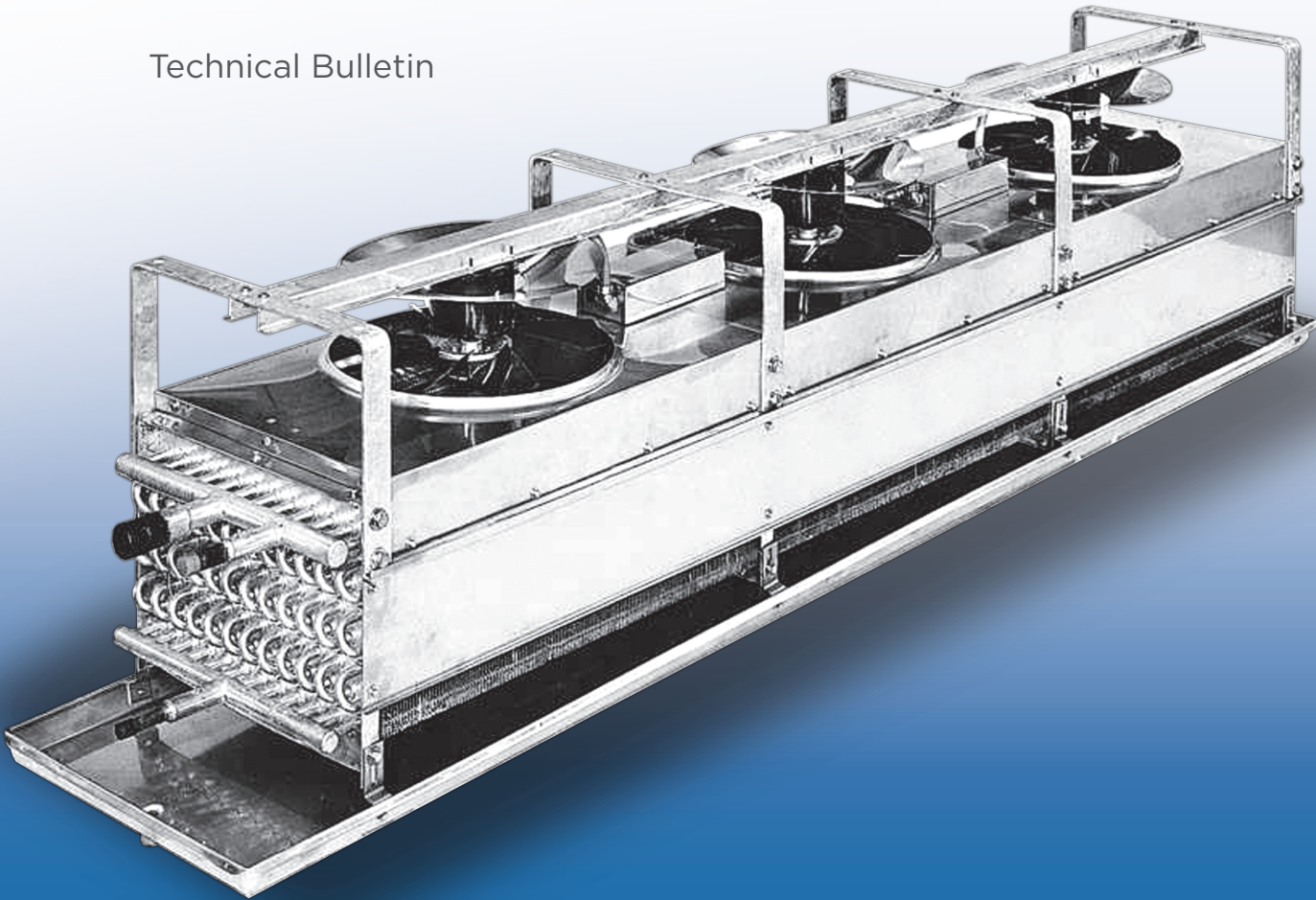

BTR SERIES UNIT COOLERS
Specifications subject to change without notice.

BTR Series Between-The-Rail Unit Coolers

Standard Features

Efficient Coil Design

Maximum heat transfer is achieved by staggered 5/8" OD tubes in the direction of air flow. Turbo-Spacers are located between tubes to provide nominal 4 FPI spacing and improve fin efficiency by turbulating the air flow.

- Steel tube/fin coils, including internal framing, used for ammonia or calcium chloride brine are hot dip galvanized after assembly.
- Copper tube/aluminum fin coils used for halocarbons, water and glycol applications.
- Stainless steel tube/aluminum fin.

Fans and Motors

- Motors, with internal overload protection, are factory wired to stainless steel Nema 1 junction boxes located on the top of the casing. All fan motors can be cycled with one contactor.
- Fan guards conform to UL requirements and have a 10-15 mil fluidic bath coating of black vinyl PVC for corrosion resistance.

BTR 20, 30, 40 and 50 Series

- 18" diameter propeller fans with plastic blades and aluminum hubs.

Single phase 50-60 Hertz 115 or 208-230 volts, 1/6 Hp, two speeds 1100/830 RPM-tapped winding capacitor start motors.

BTR 11, 21, 31 and 41 Series

- 30" diameter propeller fans with plastic blades and aluminum hubs.

Three phase 50-60 Hertz, 208-230, 380, 460 or 575 volts, 1/2 Hp totally enclosed (TEAO), one speed 1140 RPM.

Housing

- Corrosion resistant stainless steel is used for the outer casing.
- Extended housing height used for water defrost, water wash, hot gas reheat and hinged panels.

Drain Pan

Designed for full coverage, stainless steel drain pan and closed cell insulated stainless steel cover is shipped loose. Krack's exclusive stainless steel "coil-less waffle" design is provided for hot gas heated drain pan requirements. The entire pan surface is in contact with hot gas, eliminating cold spots and assuring instant warm-up.

Hot gas pans are provided with closed cell insulation between the pan and stainless steel cover. Drain pan needs to be piped in series with the evaporator coil. A pan to coil check valve is usually required (supplied by others or optionally shipped loose).

Air Defrost

(Above +36°F Room Temperature)

- Air defrost coil with a stainless steel closed cell insulated drain pan.

Hot Gas Defrost Coil Only

(Above +32°F Room Temperature)

- Hot gas defrost for the coil with an unheated stainless steel insulated drain pan.
- For steel direct expansion applications, hot gas defrost coils are supplied with a separate hot gas inlet header, which by-passes the capillaries for rapid defrost.

Hot Gas Defrost Unit

(Below +32°F Room Temperature)

- The unique "waffle" (Krack exclusive) stainless steel drain pan allows for the fastest hot gas defrost available. The design assures maximum pan heat in a minimum time.
- Drain pan provided with closed cell insulation between the pan and stainless steel cover.
- For steel direct expansion applications, hot gas defrost coils are supplied with a separate hot gas inlet header, which by-passes the capillaries for rapid defrost.

BTR Series Between-The-Rail Unit Coolers

Standard and Optional Features

Electric Defrost Coil Only

(Above +32°F Room Temperature)

- Electrical defrost heaters factory wired for 208-230/460/3/60 voltage to a common terminal block with fan delay and temperature terminations thermostat.
- Available models listed are limited 2 or 3 fans, 4 or 6 rows and can be used for steel and copper tube coils.
- Tubular heaters are located under the coil face, between coil and drain pan, and efficiently defrost the coil from the bottom to the top. Drain pan is not heated.

BTR Electrical Defrost

Model	Total KW 208/230V	Total Amps		
		208V	230V	460V
24 and 26	4.8	13.9	12.1	6.0
34 and 36	7.2	20.9	18.1	9.0

- Remote electrical panels are available to defrost up to 3 units at one time. Included are Nema 1 enclosure, main disconnect, 115V control transformer, contactors, 3 pilot lights, on/off switch and time clock.

Water Defrost

(Above +25°F Room Temperature)

Water Defrost spray headers are available for all models.

- Minimum operating supply water pressure is 5 PSI and minimum water temperature is 65°F.
- Unit heights are increased 5.25".
- Drain pan connection is 3.0 FPT. Drain pan is not insulated.

Flow Rates Required for Water Defrost

Model	GPM
20	18
30	27
40	36
50	45
11	12
21	24
31	36
41	48

Accessories

- Thermostatic Expansion Valve (TEV).
- Electrical defrost control panels (shipped loose).
- Hot gas defrost check valve (shipped loose).

Optional Features

- Single phase 50-60 Hertz 115, 208-230, 1/2 Hp totally enclosed (TEAO), single speed 1075 RPM available for Series 11-41.
- Three phase 60 Hertz 208-230, 460 volts, 1/2 Hp totally enclosed (TEAO), two speed 1140/850 RPM available for Series 11-41.
- Three phase 60 Hertz 208-230, 460 volts, 1/2 Hp totally enclosed (TEAO), 1140 RPM inverter ready motor available for Series 11-41.
- Electric heat tape 115V or 230V 1 PH on the interior of the insulated drain pan cover.
- Hot dip galvanized steel coils with brass distributor for halocarbon direct expansion feed.
- Hot gas reheat (8 rows total maximum).
- The coil fully dipped and dried with a corrosion resistant coating.
- Variable fin spacing - 2/4 FPI. Bottom two rows have 2 FPI, remainder 4 FPI (6 or 8 row depth models only).
- Nema 4x factory mounted non-fused disconnect switch.
- Hinged panels used for easy access to the coil.
- Water Wash Down models with insulated stainless steel drain pan.
- Pan to coil check valve for Hot Gas Defrost unit (shipped loose).
- Thermostatic Expansion Valve (shipped loose or factory mounted, if copper tubes).
- Side panels are removable for easy coil access.

Application

Between-the-Rail Unit Coolers are ideally suited for carcass chill and holding coolers, assembly and shipping docks; boning, cutting and packaging rooms; sausage kitchens and any space above 15°F, where people work.

Air Distribution

- Air distribution is four ways at the ceiling level. Air throw radius is 20 to 30 feet. The umbrella effect minimizes drafts.
- It is best to locate units in the center of the bays or on column lines so that the discharge path is not compromised by piping, walls or other structural interference.

Fan Motor Data

- Fan motor nameplate amps are total for the unit. Motors have internal over-heat protection, wired in parallel and cycled with one contactor.
- NEC limits total parallel motor ampacity to 15.0 amps for 208 through 600 volts and 20.0 amps at 125 volts or less. Higher capacity models for 115/1/60V can be provided when more than one parallel motor circuit is used.

- Ampacity will increase as room temperature is lowered (8% at 32°F; 18% at -10°F) due to denser air. As the air temperature lowers TEAO motor capability increases at a faster rate than the imposed fan load.
- Single phase 1/6 HP units can be controlled with manual 2-speed starters. Relays or contactors, used with automatic defrost should be arranged to cycle motors and restart motors on the high speed winding.
- Three phase 1/2 HP units with single speed motors can be controlled with conventional contactors. Two speed motors are six lead, two winding type, protected with internal overheat protectors. Normal starting methods can be used.
- When factory wired to one common junction box, motors are factory wired for proper rotation.
- Direct expansion halocarbon systems should have liquid line solenoid valves interlocked with the motor contactor, so they are de-energized when unit cooler fans are off. This is not required when compressors are protected with suction traps.

MOTOR DATA

HP	V	PH	HZ	RPM HI/LO	SPEED	FLA EACH	FLA TOTAL				
							1 Fan	2 Fan	3 Fan	4 Fan	5 Fan
BTR 11-41											
1/2	115	1	50/60	1075	1	7.80	7.80	15.60	1 x 7.8	1 x 15.6	-
									1 x 15.6	1 x 15.6	-
1/2	208/230	1	50/60	1075	1	3.90	3.90	7.80	11.70	15.60	-
1/2	208/230	3	50/60	1140	1	1.96	1.96	3.92	5.88	7.84	-
1/2	380	3	50/60	1140	1	1.10	1.10	2.20	3.30	4.40	-
1/2	460	3	50/60	1140	1	0.98	0.98	1.96	2.94	2.94	-
1/2	575	3	60	1140	1	0.76	0.76	1.52	2.28	3.04	-
1/2	208/230	3	50/60	1140/850	2	1.90	1.90	3.80	5.70	7.60	-
1/2	460	3	50/60	1175/850	2	0.87	0.87	1.74	2.61	3.48	-
BTR 20-50											
1/6	115	1	50/60	1110	1	2.82*	-	5.64	8.46	11.28	14.10
1/6	208/230	1	50/60	1110	1	1.42*	-	2.84	4.26	5.68	7.10

*Condensate drain connection.

See Capacity Correction Factors table for 50 Hz motors.

BTR Series Between-The-Rail Unit Coolers

Engineering Data

Coils

- BTR Series propeller fan units are modular in design in 1 through 4 fans Series 11-41 and 2 to 5 fans for Series 20-50.
- Units are designed for medium suction temperatures +20°F to +40°F and from 2 to 15 nominal tons.
- Maximum heat transfer is achieved by staggered 5/8" OD tubes in the direction of air flow. Turbo-Spacers are located between tubes to provide additional air turbulence.
- Each coil is tested underwater with 350 psig air, with steel coils being tested before and after galvanizing.

Material of Construction

- Hot dipped galvanized steel tube and fin.
- Copper tube with aluminum fin. Optional copper tube/copper fin is available.

Rating Data

- Each coil is engineered for maximum efficiency for its specific design application.
- Capacity listed is BTUH/°F TD sensible heat removal from the wet, dry or frosted coil. Ratings are valid for TD's 20°F or less, SST +20°F to +40°F.
- Wet coil heat transfer is more efficient than frosted resulting in higher ratings.
- Wet coil applications are for room temperatures above 32°F. All face velocities are below 600 FPM.

Capacity Correction Factors

50 Hz Electrical Power	0.88
For 2/4 Variable Fin Spacing	
6 Row Models	0.85
8 Row Models	0.89

Fan Motor Heat

- Motor heat is not included in the ratings. Add 4000 BTU/HP per motor to the load estimate.

Temperature Difference (TD)

- Temperature difference (TD) is the difference between return air temperature or room air and coil saturated refrigerant temperature.
- Rated capacity is multiplied by the TD to determine total sensible heat capacity in BTUH.

Sound Level

- Sound Level represents the relative sound pressure in decibels on the "A" scale, when measured six feet horizontally from the unit.
- Actual sound level measured in the field is dependent upon unit location, room size, height and surface "hardness" of walls, ceiling and product.

Refrigerant Feeds

Recirculated coils have liquid feed orifices to feed the coil evenly and reduce hot gas blow-by during defrost.

Units operating with an overfeed system must provide liquid at 5 PSI above saturated suction pressure and the liquid temperature within 30°F of saturated suction temperature.

- **RT** - Recirculated top feed is recommended for air, water or electric defrost. Refrigerant oil flows downhill to the suction header. This application is not recommended for hot gas defrost units.
- **RB** - Recirculated bottom feed is recommended for hot gas defrost applications. Hot gas condensate and oil flow downhill, back-flowing through the liquid feed orifices which restrict gas blow-by.

Condensate is relieved through the liquid header.

Defrost condensate relief devices must be located below the liquid connection. A float drainer should be used in series piped units only (standard configuration); unrelieved vapor will prevent complete and proper defrost cycles.

- **DX** - Direct expansion coils are circuited to have a minimum pressure drop and maintain refrigerant velocity for oil return. Direct expansion coils employ distributors and capillaries to feed each circuit. TEVs must be externally equalized and, on ammonia applications, the discharge tubes must be removed. If a unit does not have a distributor do not remove the TEV discharge tube.

Ammonia TEV applications are not recommended for suction temperatures below 0°F or with TD selections less than 12°F. If sub-cooled liquid is used, it must be specified to assure proper coil circuiting.

- **FL** - Flooded coils are circuited to minimize internal losses while maintaining minimum surge drum operating level. When closed coupled, the liquid level in the drum should be 4 inches or more above the coil. Flooded coil ratings are the same as Recirculated ratings.
- **B** - Coils can be circuited for water or brine (single-phase) refrigerants. Factory engineering is required for proper unit selection. Provide required capacity, brine type, brine concentration, room temperature, entering brine temperature and GPM for selection.

Low Humidity Applications

- Low relative humidity conditions in medium temperature spaces have been achieved with high TD coil designs coupled with variable air volume or reheat to maintain space temperature.

Single-Phase Motor Air Volume Control

- Two speed controlled by 2 stage thermostat.
- Contact factory for control panel details.

Three-Phase Motor Air Volume Control

- Volume control is achieved by cycling some single speed fans in one or more units as room temperature drops. Coil surface under off-fan continues to refrigerate dehumidifying air by convection. Soft coil frost must be removed with normal hot gas cycle or by restarting fans for air defrost cycles. Motors will be wired to individual junction boxes.
- Factory mounted line voltage thermostat with sensing bulb in an operating fan return air stream, cycles fans. Allows automatic fan cycling with single-speed motors using one or three pole contactor to control one or more units. A 5°F change in return air temperature is required. Recommended for 35°-55°F docks or work spaces with liquid Recirculated feeds. Arrange for defrost as above.

Reheat

- Hot Gas Reheat employing 2 rows of surface available for all units and located on the fan side of the unit; 8 rows total maximum.
- An air gap between fins separates them from the refrigerant surface. Unit height remains the same for total rows required. Contact factory for cooling capacity.
- Coil frosting requires defrost cycles to be manual or automatically scheduled in accordance with space operations, such as after clean-up cycles.

Drain Pan Cover Heating

- In rooms that may have humidity condensate dripping from the drain pan cover a heat tape is available to warm the cover.
- The electric heat tape is affixed to the inside of the pan cover with the tail out the side of the pan.
- 115/1 and 230/1 voltages.

DRAIN PAN HEAT TAPE FLA

BASE MODEL	TOTAL WATTS	AMPS		MAX FUSE SIZE
		115V	230V	
20	580	5.04	2.52	15.00
30	800	6.96	3.48	15.00
40	1020	8.87	4.43	15.00
50	1240	10.78	5.39	15.00
11	760	6.61	3.30	15.00
21	1280	11.13	5.57	15.00
31	1800	15.65	7.83	20.00
41	2320	20.17	10.09	20.00

Thermostatic Expansion Valve (TEV)

- Thermostatic Expansion Valve (TEV) must be externally equalized.

BTR Series Between-The-Rail Unit Coolers

Ordering Information

When Ordering, Please Specify:

- Quantity and complete model number
- SST-Saturated suction temperature
- Room temperature
- Fan motor voltage
- Heater voltage (if applicable)
- Control voltage (if applicable)
- Number of drawings for approval – Not released for manufacture.
- Manufacture commences with order approval.

Krack reserves the right to change or revise specifications and product design in connection with any feature of our products.

Such changes do not entitle the buyer to corresponding changes, improvements, additions or replacements for equipment previously sold or shipped.

Model Key

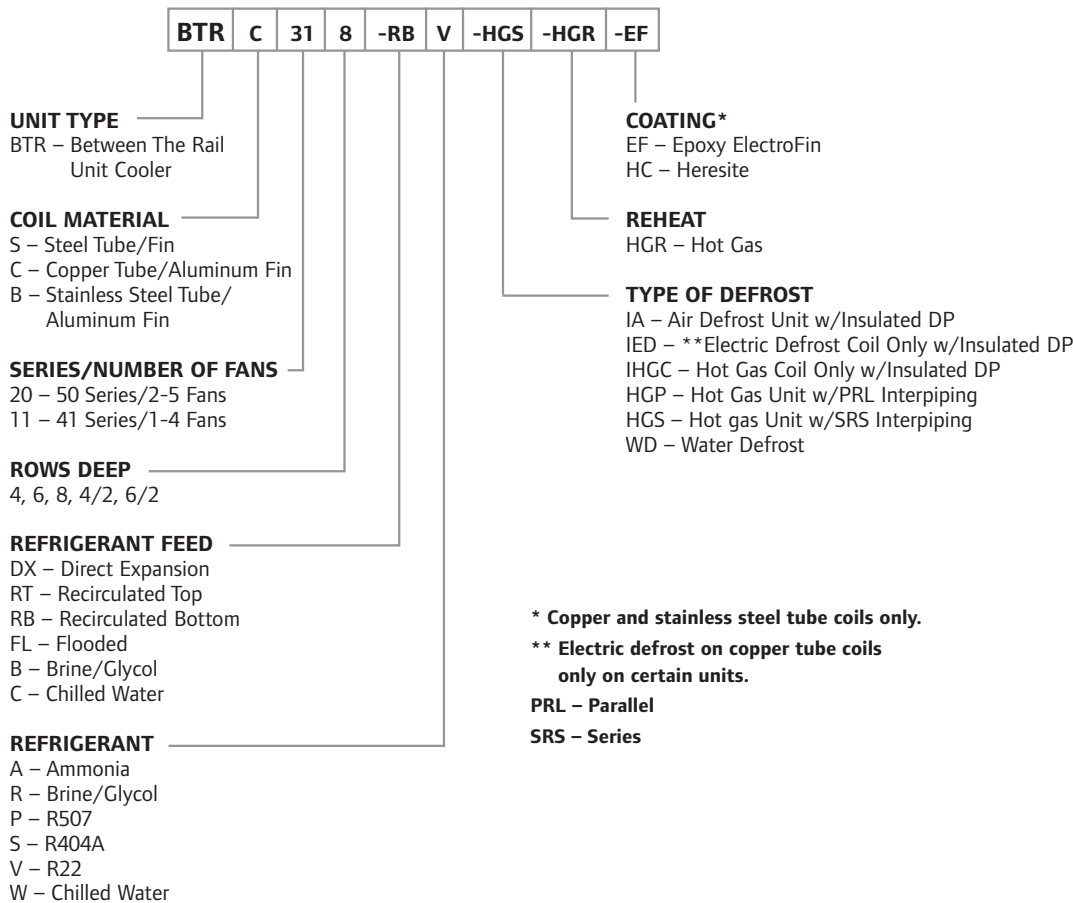

Performance Data – Steel and Copper

MODEL	ROWS DEEP	CAPACITY BTUH/F				COIL DATA			AIR DATA		FANS NO/HP	SOUND LEVEL db (A)	APPROX. SHIPPING WEIGHT (LBS)	
		HIGH SPEED		LOW SPEED		FACE FT.2	SUR-FACE FT.2	COIL VOL FT.3	CFM				STEEL	COPPER
		DX	REC	DX	REC				HI-RPM	LO-RPM				
BTR-24	4	2000	2360	1700	1900	9.9	468	0.54	4000	3000	(2) 1/6	66.5	580	420
BTR-26	6	2600	2900	2180	2340	9.9	705	0.81	3900	2900	(2) 1/6	67.0	710	470
BTR-28	8	3000	3300	2440	2600	9.9	938	1.08	3700	2800	(2) 1/6	67.5	860	510
BTR-34	4	3000	3540	2550	2850	14.9	703	0.79	6000	4500	(3) 1/6	67.5	850	610
BTR-36	6	3900	4350	3270	3500	14.9	1055	1.19	5850	4350	(3) 1/6	68.0	1040	670
BTR-38	8	4500	4950	3660	3850	14.9	1408	1.58	5550	4200	(3) 1/6	68.5	1300	740
BTR-44	4	4000	4720	3400	3800	19.8	946	1.16	7980	6000	(4) 1/6	68.5	1140	830
BTR-46	6	5200	5800	4360	4680	19.8	1422	1.74	7780	5800	(4) 1/6	69.0	1400	920
BTR-48	8	6000	6600	4880	5200	19.8	1895	2.30	7380	5600	(4) 1/6	69.5	1700	1020
BTR-54	4	5000	5910	4260	4760	24.8	1186	1.69	10,020	7500	(5) 1/6	69.0	1400	1000
BTR-56	6	6500	7260	5460	5850	24.8	1780	2.54	9770	7250	(5) 1/6	69.5	1730	1100
BTR-58	8	7500	8270	6110	6510	24.8	2370	3.36	9270	7000	(5) 1/6	70.0	2160	1220
BTR-114	4	2430	2870	2060	2435	10.4	508	0.56	6000	4500	(1) 1/2	77.5	650	450
BTR-116	6	3150	3650	2630	3050	10.4	762	0.84	5700	4270	(1) 1/2	78.0	800	550
BTR-118	8	3640	4120	2950	3340	10.4	1016	1.11	5400	4050	(1) 1/2	78.5	950	650
BTR-214	4	4860	5740	4120	4870	20.8	1016	1.11	12,000	9000	(2) 1/2	79.5	1180	870
BTR-216	6	6300	7300	5260	6100	20.8	1524	1.67	11,400	8550	(2) 1/2	80.0	1460	1050
BTR-218	8	7280	8240	5900	6680	20.8	2032	2.23	10,800	8100	(2) 1/2	80.5	1800	1150
BTR-314	4	7300	8610	6200	7310	31.3	1524	1.67	18,000	13,500	(3) 1/2	82.0	1730	1260
BTR-316	6	9450	10,960	7900	9150	31.3	2286	2.51	17,100	12,820	(3) 1/2	82.5	2060	1490
BTR-318	8	10,920	12,440	8840	10,075	31.3	3048	3.34	16,200	12,150	(3) 1/2	83.0	2550	1630
BTR-414	4	9720	11,460	8240	9740	41.7	2032	2.22	24,000	18,000	(4) 1/2	84.0	2100	1600
BTR-416	6	12,600	14,600	10,520	12,200	41.7	3048	3.34	22,800	17,100	(4) 1/2	84.5	2800	1940
BTR-418	8	14,560	16,480	11,800	13,360	41.7	4064	4.46	21,600	16,200	(4) 1/2	85.0	3500	2100

BTR Series Between-The-Rail Unit Coolers

Performance Data – Stainless Steel Tubes/Aluminum Fins

MODEL	ROWS DEEP	CAPACITY BTUH/F				COIL DATA			AIR DATA		FANS NO/HP	SOUND LEVEL db (A)	APPROX. SHIPPING WEIGHT (LBS)
		HIGH SPEED		LOW SPEED		FACE FT.2	SUR-FACE FT.2	COIL VOL FT.3	CFM				STAINLESS STEEL
		DX	REC	DX	REC				HI-RPM	LO-RPM			
BTR-24	4	2300	2710	1960	2190	9.9	468	0.54	4000	3000	(2) 1/6	66.5	420
BTR-26	6	2940	3280	2460	2640	9.9	705	0.81	3900	2900	(2) 1/6	67.0	470
BTR-28	8	3330	3660	2710	2890	9.9	938	1.08	3700	2800	(2) 1/6	67.5	510
BTR-34	4	3450	4070	2930	3280	14.9	703	0.79	6000	4500	(3) 1/6	67.5	610
BTR-36	6	4410	4920	3700	3960	14.9	1055	1.19	5850	4350	(3) 1/6	68.0	670
BTR-38	8	5000	5490	4060	4270	14.9	1408	1.58	5550	4200	(3) 1/6	68.5	740
BTR-44	4	4600	5430	3910	4370	19.8	946	1.16	7980	6000	(4) 1/6	68.5	830
BTR-46	6	5880	6550	4930	5290	19.8	1422	1.74	7780	5800	(4) 1/6	69.0	920
BTR-48	8	6660	7330	5420	5770	19.8	1895	2.30	7380	5600	(4) 1/6	69.5	1,020
BTR-54	4	5750	6800	4900	5470	24.8	1186	1.69	10,020	7500	(5) 1/6	69.0	1,000
BTR-56	6	7350	8200	6170	6610	24.8	1780	2.54	9770	7250	(5) 1/6	69.5	1,100
BTR-58	8	8330	9180	6780	7230	24.8	2370	3.36	9270	7000	(5) 1/6	70.0	1,220
BTR-114	4	2790	3300	2370	2800	10.4	508	0.56	6000	4500	(1) 1/2	77.5	450
BTR-116	6	3560	4120	2970	3450	10.4	762	0.84	5700	4270	(1) 1/2	78.0	550
BTR-118	8	4040	4570	3270	3710	10.4	1016	1.11	5400	4050	(1) 1/2	78.5	650
BTR-214	4	5590	6600	4740	5600	20.8	1016	1.11	12,000	9000	(2) 1/2	79.5	870
BTR-216	6	7120	8250	5940	6890	20.8	1524	1.67	11,400	8550	(2) 1/2	80.0	1,050
BTR-218	8	8080	9150	6550	7410	20.8	2032	2.23	10,800	8100	(2) 1/2	80.5	1,150
BTR-314	4	8400	9900	7130	8410	31.3	1524	1.67	18,000	13,500	(3) 1/2	82.0	1,260
BTR-316	6	10,680	12,380	8930	10,340	31.3	2286	2.51	17,100	12,820	(3) 1/2	82.5	1,490
BTR-318	8	12,120	13,810	9810	11,180	31.3	3048	3.34	16,200	12,150	(3) 1/2	83.0	1,630
BTR-414	4	11,180	13,180	9480	11,200	41.7	2032	2.22	24,000	18,000	(4) 1/2	84.0	1,600
BTR-416	6	14,240	16,500	11,890	13,790	41.7	3048	3.34	22,800	17,100	(4) 1/2	84.5	1,940
BTR-418	8	16,160	18,290	13,100	14,830	41.7	4064	4.46	21,600	16,200	(4) 1/2	85.0	2,100

Coil Connection Data

MODEL	COPPER TUBE - 15°F TD		STEEL/STAINLESS STEEL TUBE - 15°F TD						DRAIN PAN		
	DXV		DXA		RTA/RBA		FLA		DRAIN CONN* **	HOT GAS CONNECTION	
	DIST ODF	SUCT ODS	DIST FPT	SUCT**	LIQ**	SUCT**	LIQ**	SUCT**		HALO- CARBON OD	AMMONIA MPT
BTR-24	5/8	1-1/8	1/2	3/4	1/2	1-1/4	1-1/2	1-1/2	3/4	7/8	3/4
BTR-26	5/8	1-1/8	1/2	3/4	1/2	1-1/4	1-1/2	1-1/2	3/4	7/8	3/4
BTR-28	7/8	1-3/8	1/2	1	1/2	1-1/4	1-1/2	1-1/2	3/4	7/8	3/4
BTR-34	7/8	1-3/8	1/2	1	1/2	1-1/4	1-1/2	1-1/2	3/4	7/8	3/4
BTR-36	7/8	1-3/8	1/2	1-1/4	1/2	1-1/2	1-1/2	1-1/2	3/4	7/8	3/4
BTR-38	7/8	1-5/8	1/2	1-1/4	1/2	1-1/2	1-1/2	1-1/2	3/4	7/8	3/4
BTR-44	7/8	1-3/8	1/2	1-1/4	1/2	1-1/2	1-1/2	1-1/2	1	1-1/8	1
BTR-46	7/8	1-5/8	1/2	1-1/4	3/4	2	2	2	1	1-1/8	1
BTR-48	7/8	2-1/8	1/2	1-1/4	3/4	2	2	2	1	1-1/8	1
BTR-54	7/8	1-5/8	1/2	1-1/4	3/4	2	2	2	1	1-1/8	1
BTR-56	1-1/8	2-1/8	1/2	1-1/2	3/4	2	2	2	1	1-1/8	1
BTR-58	1-1/8	2-1/8	1/2	1-1/2	3/4	2	2	2	1	1-1/8	1
BTR-114	7/8	1-3/8	1/2	1	1/2	1-1/2	1-1/2	1-1/2	1-1/2	1-1/8	1
BTR-116	7/8	1-3/8	1/2	1	1/2	1-1/2	1-1/2	1-1/2	1-1/2	1-1/8	1
BTR-118	7/8	1-5/8	1/2	1-1/4	1/2	1-1/2	2	2	1-1/2	1-1/8	1
BTR-214	7/8	1-5/8	1/2	1-1/4	1/2	1-1/2	2	2	1-1/2	1-1/8	1
BTR-216	7/8	2-1/8	1/2	1-1/2	1/2	2	2	2	1-1/2	1-1/8	1
BTR-218	1-3/8	2-1/8	1/2	1-1/2	3/4	2	2	2	1-1/2	1-1/8	1
BTR-314	1-1/8	2-1/8	1/2	1-1/2	3/4	2	2	2	1-1/2	1-1/8	1
BTR-316	1-3/8	2-1/8	1/2	1-1/2	3/4	2	2-1/2	2-1/2	1-1/2	1-1/8	1
BTR-318	1-3/8	2-5/8	1/2	2	3/4	2	2-1/2	2-1/2	1-1/2	1-1/8	1
BTR-414	1-3/8	2-1/8	1/2	1-1/2	3/4	2	2-1/2	2-1/2	1-1/2	1-5/8	1-1/2
BTR-416	1-3/8	2-5/8	1/2	2	3/4	2-1/2	2-1/2	2-1/2	1-1/2	1-5/8	1-1/2
BTR-418	1-3/8	2-5/8	3/4	2	1	2-1/2	2-1/2	2-1/2	1-1/2	1-5/8	1-1/2

*Condensate drain connection.

** Steel connections are MPT, stainless steel connections are IPS.

BTR Series Between-The-Rail Unit Coolers

Dimensional Drawings

BTR 24-58

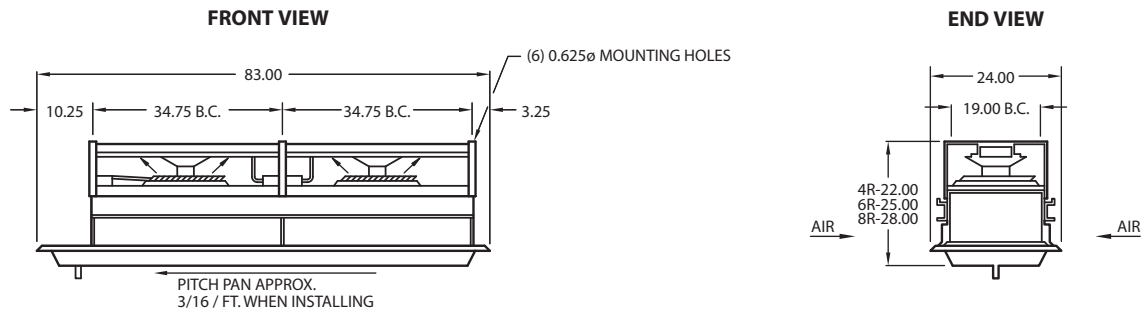

24-26-28

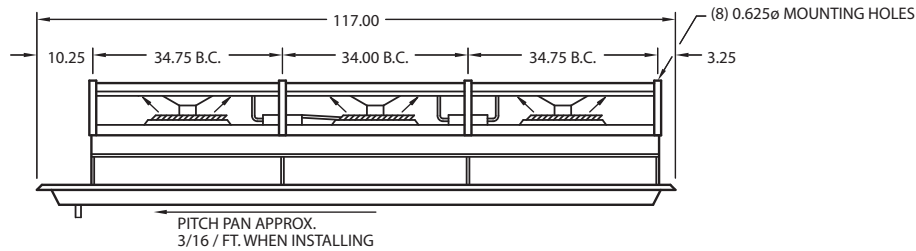

34-36-38

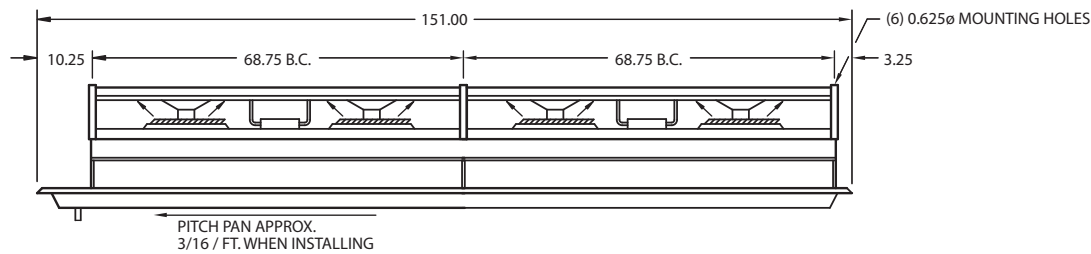

44-46-48

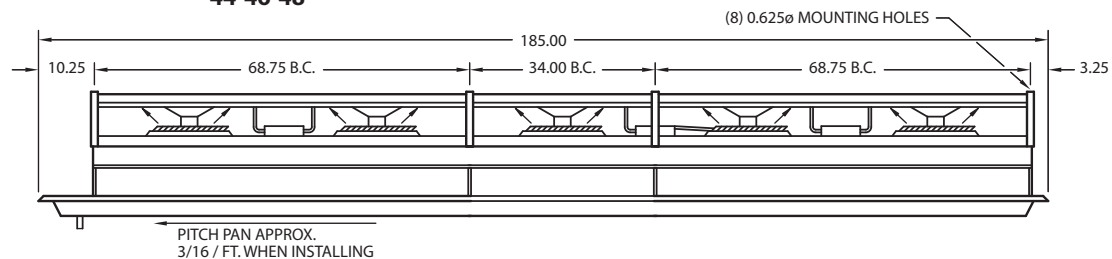

54-56-58

1. ALL DIMENSIONS ARE IN INCHES.
2. HANGER HOLES ARE 5/8" DIA FOR 1/2" DIA. ROD HANGERS.
3. DRAWINGS ARE FOR GENERAL REFERENCE - DO NOT USE FOR CONSTRUCTION PURPOSES.
4. HEIGHT INCREASE 5-1/4" DUE TO WATER DEFROST AND EXTENDED HEIGHT SIDE PANELS.
5. MAIN POWER CONNECTION AVAILABLE AT ANY JUNCTION BOX.

10 BTR SERIES UNIT COOLERS

Specifications subject to change without notice.

Dimensional Drawings

BTR 114-418

FRONT VIEW

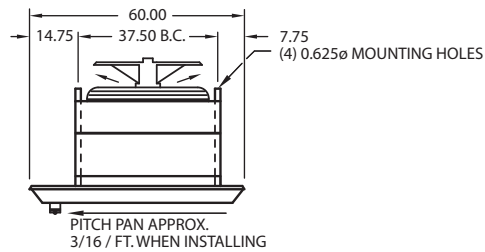

114-116-118

END VIEW

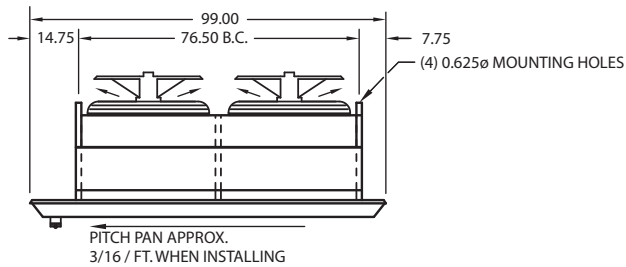
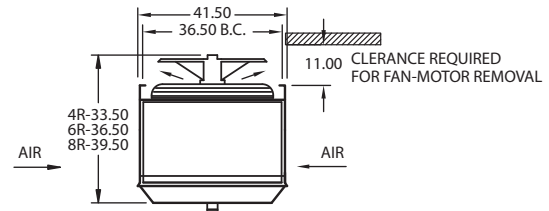

214-216-218

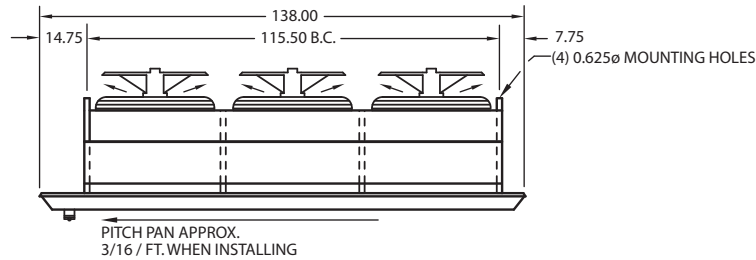

314-316-318

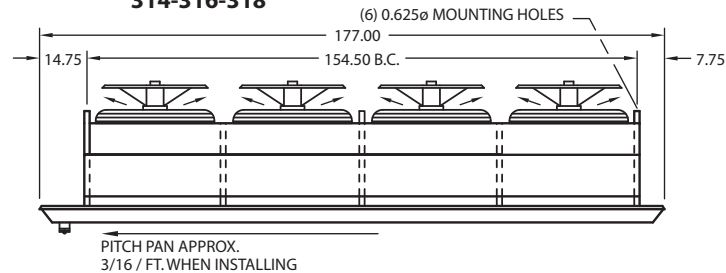

414-416-418

1. ALL DIMENSIONS ARE IN INCHES.
2. HANGER HOLES ARE 5/8" DIA FOR 1/2" DIA. ROD HANGERS.
3. DRAWINGS ARE FOR GENERAL REFERENCE - DO NOT USE FOR CONSTRUCTION PURPOSES.
4. HEIGHT INCREASE 5-1/4" DUE TO WATER DEFROST AND EXTENDED HEIGHT SIDE PANELS.
5. MAIN POWER CONNECTION AVAILABLE AT ANY JUNCTION BOX.

BTR SERIES UNIT COOLERS
Specifications subject to change without notice.



SGS Refrigeration, Inc.

827 W. Progress Drive

Dixon, IL 61021

Ph: 815.284.2700

sgsrefrigeration.com