

Custom Conventional Units

Installation / Service Manual

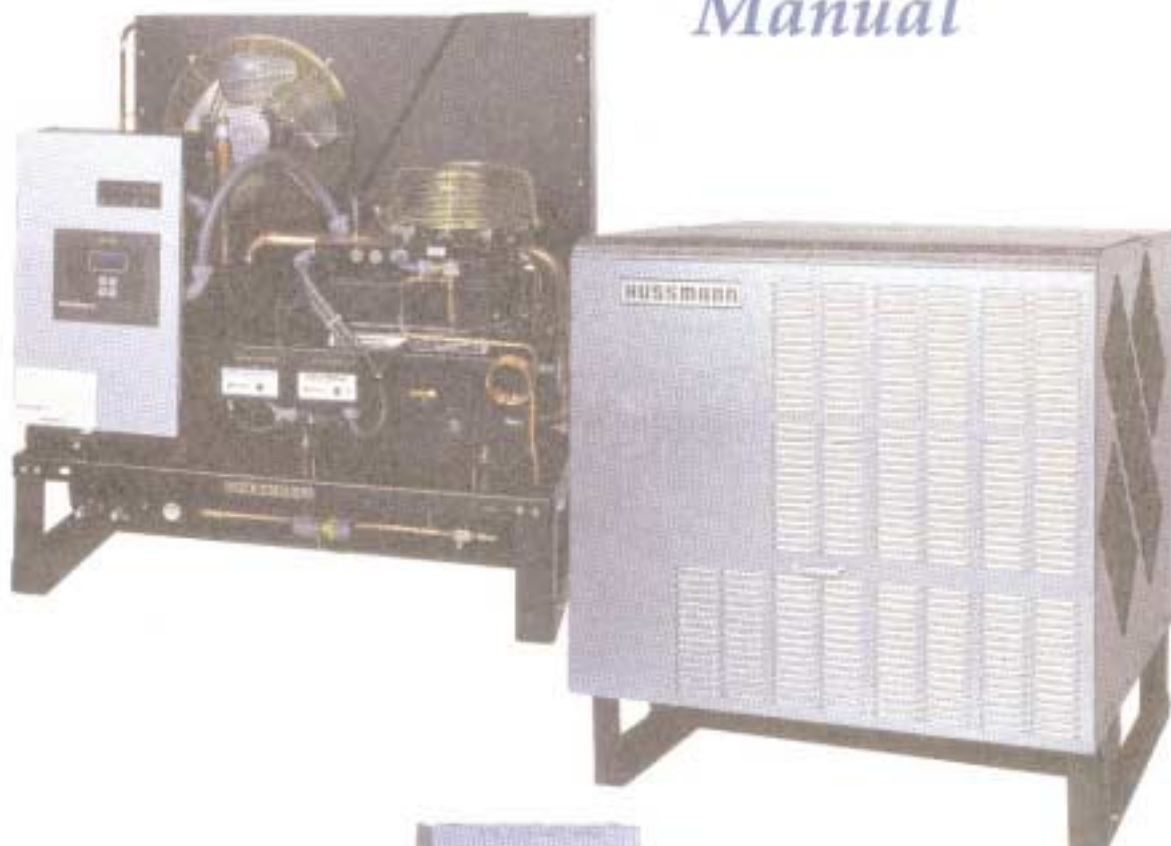

P/N 311859E
November, 1997

TABLE OF CONTENTS

Topics	Figures
1. Installation	
Overview	1-1
Shipping Damage	1-1
Rigging and Hoisting	1-1
Isolation Pads	1-2
Product Code	1-3
Base Dimensions	1-4
Unit Weights	1-5
Quad-Ventional Weights	1-7
Quad-Ventional Dimensions	1-7
Machine Room Requirements	1-8
Unit Placement	1-9
Shipping Block Removal	1-9
2. Refrigeration	
Overview	2-1
Refrigeration Cycle	2-1
Heat Reclaim	
Valve	2-3
Description	2-4
Location and Mounting	2-4
Low Ambient Controls	
Adjustable Flooding Valve and Check Valve	2-5
Fixed Flooding Valve	2-6
Liquid Line Solenoid Valve	2-6
TEV	2-7
EPR Valve	2-8
CPR Valve	2-9
Demand Cooling	2-9
Copeland Scroll Compressors	2-11
Reverse Cycle Defrost	2-12
Temperature Control	2-15
Refrigeration Cycle	2-1
Heat Reclaim Valve	2-2
Adjustable Flooding Valve and Check Valve	2-2
Fixed Flooding Valve	2-2
Liquid Line Solenoid	2-2
TEV	2-2
EPR Valves	2-3
Heat Reclaim Valve	2-3
Heat Reclaim Expansion Ratios	2-4
Heat Reclaim	
Smoothing Air Velocities	2-5
Heat Reclaim with	
Air Conditioning Coil	2-5
Adjustable Flooding Valve and Differential Check Valve	2-5
Fixed Flooding Valve	2-6
Liquid Line Solenoid Valve	2-7
TEV	2-7
Probe Locations for Setting TEV	2-8
Direct Acting EPR Valve	2-8
Pilot Operated EPR Valve	2-8
Direct Acting CPR Valve	2-9
Pilot Port CPR Valve	2-9

TABLE OF CONTENTS (Continued)

Topics	Figures
2. Refrigeration (continued)	
	Demand Cooling Components 2-10
	Demand Cooling Wiring 2-11
	Demand Cooling Alarm Connections . . . 2-11
	Liquid Injection Schematic 2-11
	Pilot Valve Operation 2-12
	Reversing Valve Connections 2-13
	Heat Reclaim with Reverse Cycle Defrost 2-13
	Reverse Cycle Defrost – Refrigeration and Defrost Modes 2-14
3. Piping	
Overview 3-1	Supporting Refrigeration Lines 3-1
Refrigeration Line Runs 3-1	Insulating a Riser 3-2
Merchandiser Piping 3-4	Vibration Allowance 3-2
Special Piping for Open Rooms 3-5	P-Trap Construction 3-2
Run Lengths and Equivalent Feet 3-5	Reduced Riser 3-2
Insulation 3-5	HIRU to Condenser Piping 3-3
	Line Piping Inside Merchandisers 3-4
	Equivalent Feet for Angle Valve and Elbow 90° 3-5
4. Electrical	
Overview 4-1	8145 Timer 4-2
Field Wiring 4-1	8245 Timer 4-3
Wiring Guidelines Based on	A633 Timer 4-3
Various Components 4-1	CD104MB Timer 4-4
Electrical Diagrams in this Section 4-2	Heat Reclaim Circuits 4-4
Defrost Timers 4-2	Heat Reclaim Circuit with
Heat Reclaim Circuits 4-4	Reverse Cycle Defrost 4-5
Fan Cycling Circuits 4-5	Single Fan Circuits 4-5
440V Compressors 4-6	Fan Bank Circuits 4-5
Electric Defrost 4-6	Cycling Fan Bank Circuits 4-5
Copeland Scroll Compressors 4-12	Variable Speed Fan Control 4-5
Additional Timer Circuits with	Cycling Fan Bank Circuits with
Reverse Cycle Defrost 4-13	Reverse Cycle Defrost 4-6

TABLE OF CONTENTS (Continued)

Topics	Figures
4. Electrical (continued)	
Variable Speed Fan Control with Reverse Cycle Defrost	4-6
440V Compressor with 230/208V Control Panel	4-7
Defrost Sub Breaker Wiring	4-7
8145 Indoor Clock Schematic	4-8
8245 Indoor Clock Schematic	4-9
A633 Outdoor Clock Schematic	4-10
CD104MB Clock Over 110 Min	4-11
Liquid Injection Wiring	4-12
Wiring for Discharge Thermostat and Trax-Oil	4-12
Timer Circuits with Reverse Cycle Defrost	4-12

5. Control Settings

Startup	5-1
Control Settings	5-4
Service	5-6

Warranty

SAFETY TIPS

Being Safe is Your Responsibility.

Wear proper eye protection whenever working.

Wear proper hearing protection whenever working in a machine room.

Stand to one side—never work directly in front of:

- Any valve you are opening or closing
 - Manual refrigeration valves
 - Regulator valves on brazing tanks and nitrogen tanks
- Electrical Circuit Breakers
- Refrigeration lines you are cutting or opening

Always use a pressure regulator with a nitrogen tank.

- Do not exceed 2 pounds of pressure and vent lines when brazing.
- Do not exceed 350 pounds of pressure for leak testing high side.
- Do not exceed 150 pounds of pressure for leak testing low side.

Use only a striker to light torch.

Know whether a circuit is open at the power supply or not. Remove all power before opening control panels.

Always supply proper ventilation.

- Refrigerants and nitrogen can displace oxygen causing suffocation.
- Refrigerants exposed to flame can produce phosgene, a poisonous gas.

Be sure refrigeration lines are free of pressure before cutting. Check:

- Both sides of a two way valve
- All lines to a 3-way or 4-way valve

Dangerous hydraulic explosions may result if you

- Isolate liquid lines or compressor when they can absorb heat over an extended time period
- Overfill pumpdown refrigerant containers

Never vent refrigerants into the atmosphere.

INSTALLATION INSTRUCTIONS

OVERVIEW

This section is limited to the information needed to set the HICA, HOCA, HIRU and Quad-Ventional units. Power Supply requirements are found under *Electrical*; piping, under *Piping*; and charging, under *Startup and Maintenance*. Auxiliary units are found in the sections devoted to them or in the manuals accompanying them.

SHIPPING DAMAGE

All equipment should be thoroughly examined for shipping damage before and while unloading.

This equipment has been carefully inspected at our factory and the carrier has assumed responsibility for safe arrival. If damaged, either apparent or concealed, claim must be made to the carrier.

Apparent Loss or Damage

If there is an obvious loss or damage, it must be noted on the freight bill or express receipt and signed by the carrier's agent; otherwise, carrier may refuse claim. The carrier will supply the necessary claim forms.

Concealed Loss or Damage

When loss or damage is not apparent until after equipment is uncrated, a claim for concealed damage is made. Upon discovering damage, make request in writing to carrier for inspection within 15 days and retain all packing. The carrier will supply inspection report and required claim forms.

RIGGING AND HOISTING

Under no circumstances should the manifolds, piping return bends or control panel be used for lifting or moving the unit. Use lifting eyes provided on the two tier units. On single tier units, secure lifting hooks to the under side of the base. The installer is responsible to see that equipment used to move the units is operated within its limits.

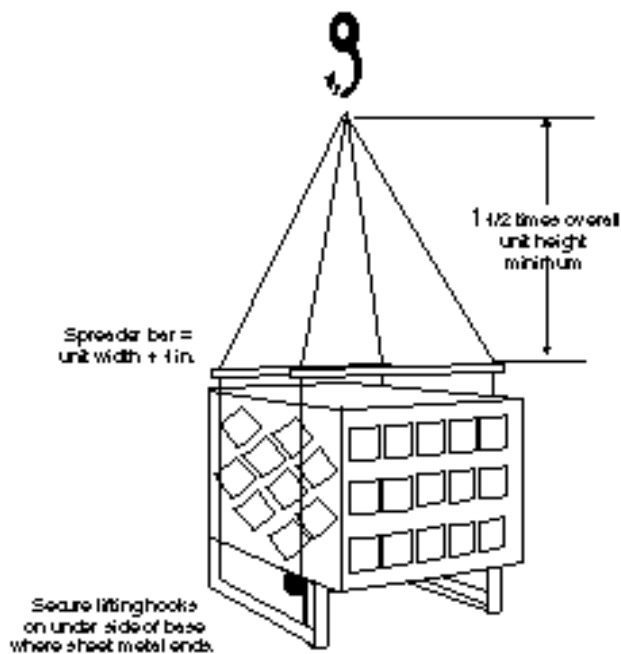
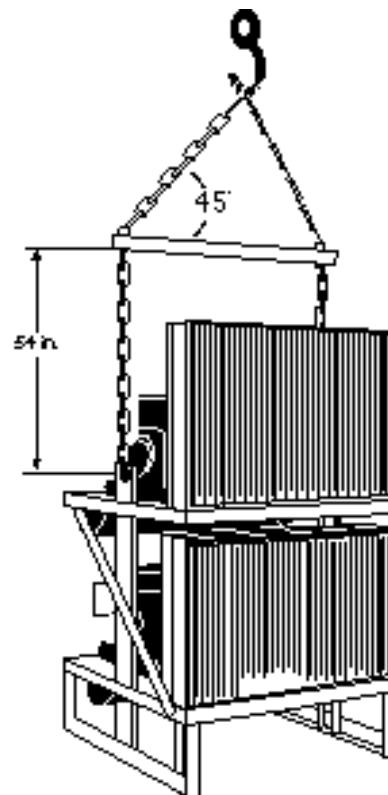

P/N 311859E

1 - 2

On the Quad-Ventional, rigging should lift the frame just below the compressors. A hook and safety strap should be used since the control panel makes the unit top heavy toward the back.

When using a fork lift, extra care should be taken to prevent the unit from tipping backward.

ISOLATION PADS

The Quad-Ventional is shipped with 6 Isolation Pads. If a shim is used to adjust for a slightly uneven floor, it must go under the Isolation Pad. Shims are field supplied and should be the same size as the Pads. The Pads are used running lengthwise with the base.

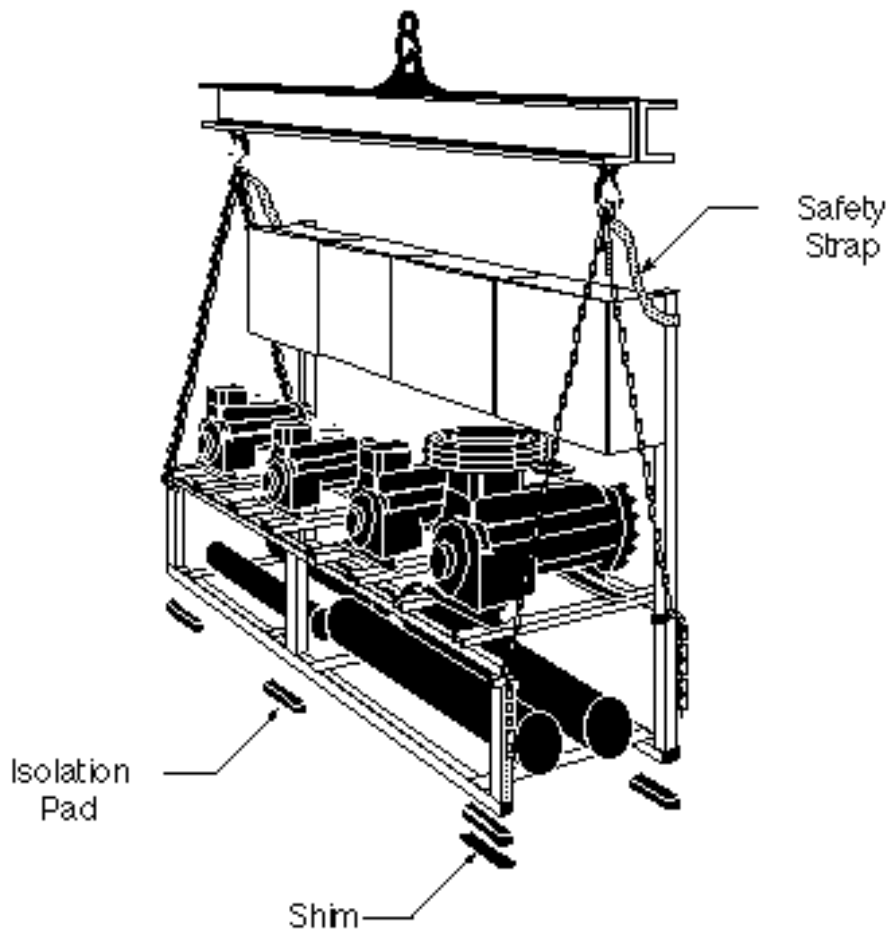
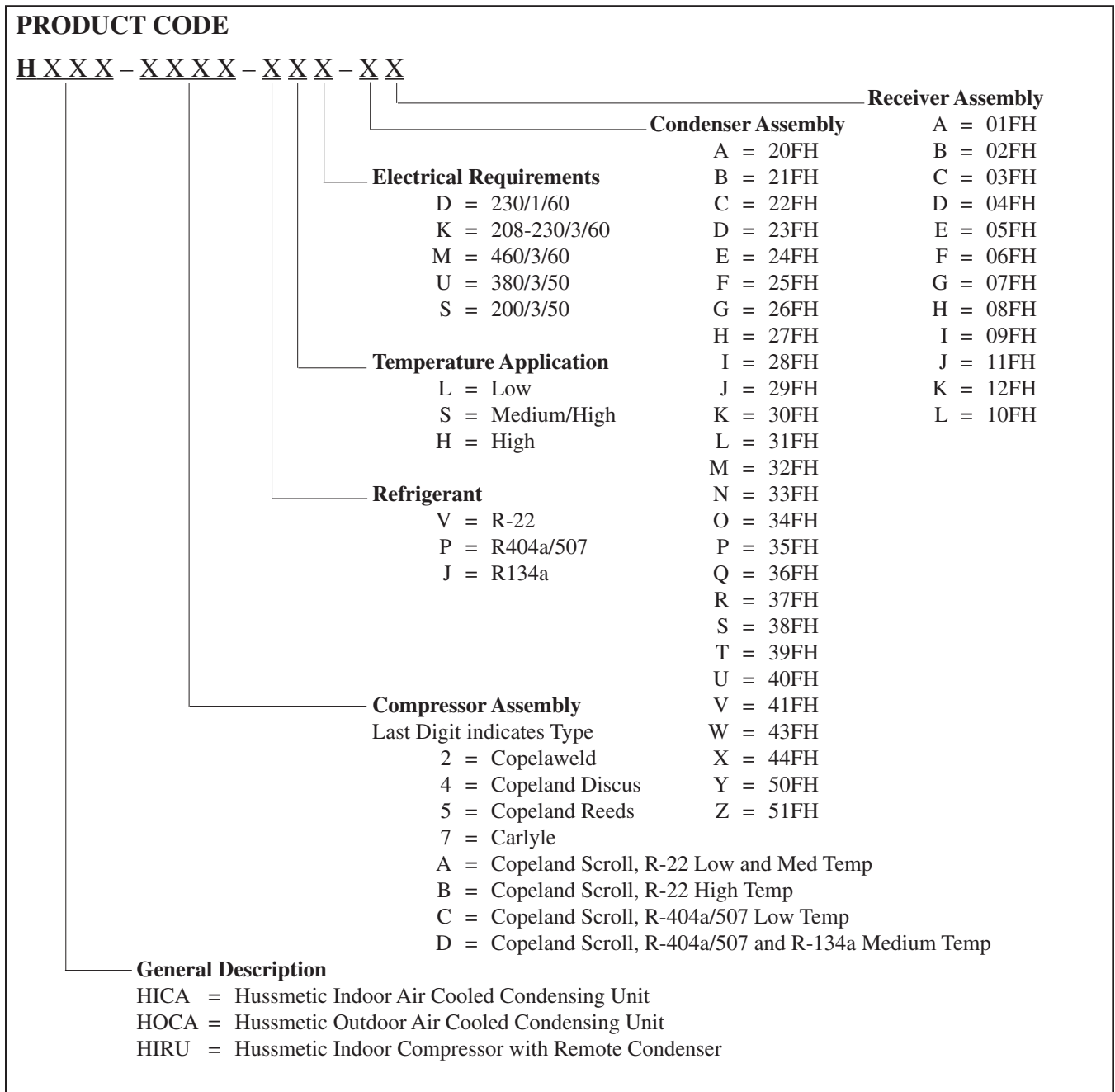

Figure 1-2 Rigging and Lifting



BASE DIMENSIONS

Single Compressor Application

	Nominal hp	Length (in.)	Depth (in.)	Height (in.)
HICA	01 - 04	39	29½	40 Max
	05 - 10	47	37	50 Max
	*12 - 25	47	37	91 Max
HOCA	01 - 04	39	34	40 Max
	05 - 10	47	44	50 Max
	*12 - 30	94	44	50 Max
HIRU	01 - 04	39	29½	37 Max
	05 - 25	47	37	45 Max

*HICA units with condenser assemblies larger than 31FH utilize two parallel condensers. These are stacked on a Two-Tier frame.

HOCA units of 15 nominal hp and above with condenser assemblies larger than 31FH require a double-wide housing to hold the single coil double-length condenser.

Two-Tier Application

Length and Depth equal single compressor application for the bottom tier. Since the mounting surface for the top tier is always 53 in. high the total unit height is determined by the top tier height + 53 in.

HICA	Top Tier Compressor Nominal HP	Total Height (in.)
	01	73
	1½	79
	02 - 04	81
	05 - 06	85
	7½ - 12	91

The height of Two-Tier HIRU units depends on the height of the top control panel. The total height maximum is 87 in.

UNIT WEIGHTS

With Modular Conventional Units the customer can build units specific to particular needs. Compressors, condensers (including frame), and

receivers may be selected in a variety of combinations. To determine approximate weights add the component weights together.

Compressor Weights		Hermetic COPELAWELD		Semi-Hermetic COPELAND (cont'd)		Semi-Hermetic COPELAND (cont'd)	
Scroll COPELAND		Assembly 4 Numbers of Product Code	Weight (lbs)	Assembly 4 Numbers of Product Code	Weight (lbs)	Assembly 4 Numbers of Product Code	Weight (lbs)
Assembly 4 Numbers of Product Code	Weight (lbs)						
030A	65	0152	70	0225	178	2504	435
035A	68	0202	72	0245	180	2704	498
040A	85	0252	79	0304	265	2824	440
050A	94	0312	80	0305	230	3014	535
060A	95	0352	91	0315	231	3025	535
075A	225	0402	91	0326	231		
100A	225	0502	95	0335	197		
030B	65	0752	180	0355	197		
035B	68	0902	180	0356	262		
040B	85			0475	242		
050B	94			0404	265		
060B	95			0484	265		
075B	225			0494	265		
090B	225			0504	265		
100B	225			0524	265		
130B	240			0604	265		
030C	65			0654	285		
035C	68			0704	285		
040C	85			0724	355		
050C	94			0734	355		
060C	95			0934	370		
075C	225			1064	370		
100C	225			1204	380		
030D	65			1314	380		
035D	68			1464	380		
040D	85			1514	412		
050D	94			1964	415		
060D	95			2025	421		
075D	225			2204	420		
100D	225						

Semi-Hermetic CARLYLE	
Assembly 4 Numbers of Product Code	Weight (lbs)
0227	145
0317	150
0337	213
0457	213
0477	213
0527	213
0537	228
0677	243
0687	288
0767	295
1027	303
1107	303

Condenser Weights				
Assembly Next to Last Letter of Product Code	Weight (lbs)	Number of ½ hp Fans	HOCA Outdoor Housing*	
			Length x Depth x Ht (in.)	Weight (lbs)
A (20FH)	235	1	39 x 34 x 35	52
B (21FH)	225	1	39 x 34 x 35	52
C (22FH)	265	1	39 x 34 x 40	58
D (23FH)	280	1	39 x 34 x 40	58
E (24FH)	300	1	39 x 34 x 40	58
F (25FH)	320	2	47 x 44 x 44	81
G (26FH)	340	2	47 X 44 x 44	81
H (27FH)	365	2	47 x 44 x 50	92
I (28FH)	375	2	47 x 44 x 50	92
J (29FH)	390	3	47 x 44 x 50	92
K (30FH)	400	3	47 x 44 x 50	92
L (31FH)	410	3	47 x 44 x 50	92
M (32FH)	720	4		
N (33FH)	735	4		
O (34FH)	750	4		
P (35FH)	770	6		
Q (36FH)	785	6		
R (37FH)	800	6		
S (38FH)	720	4	94 x 44 x 50	161
T (39FH)	735	4	94 x 44 x 50	161
U (40FH)	770	6	94 x 44 x 50	161
V (41FH)	785	6	94 x 44 x 50	161
W (43FH)	800	6	94 x 44 x 50	161
X (44FH)	825	8	94 x 44 x 63	161
HIRU Application Base Only				
Y (50FH)	175	0		
Z (51FH)	210	0		

*Add Outdoor Housing weight to HOCA units when figuring total weights
Height includes the base.

Conventional Receiver Weights				
Assembly Last Letter of Product Code	Dimensions (in.)	Weight (lbs)	80% Charge	
			R-22 (lbs)	R-404a (lbs)
A (01FH)	6 x 29	29	24	21
B (02FH)	8 ⅝ x 29	40	48	42
C (03FH)	8 ⅝ x 38	60	64	56
D (04FH)	8 ⅝ x 45	72	77	66
E (05FH)	9 ¾ x 29	50	60	51
F (06FH)	9 ¾ x 38	70	80	69
G (07FH)	9 ¾ x 45	76	96	82
I (09FH)	10 ¾ x 45	117	117	102
K (12FH)	8 ⅝ x 92	143	160	139
L (11FH)	8 ⅝ x 84	136	146	1xx

QUAD-VENTIONAL WEIGHTS

To figure the weight of a Quad-Ventional unit, add the compressor weights and the receiver weights to the rack base weight of 1,000 pounds.

The compressors are the same as for conventional units (except for mounting), but the receivers are different. Use the table below for Quad-Ventional receiver weights.

QUAD-VENTIONAL DIMENSIONS

The unit is 84 in. long by 76 in. high by 31 in. deep. Depth measurement includes space for the piping and accessories on the back of the unit. The height includes 1 in. for isolation pads.

Quad-Ventional Receiver Weights				
Assembly Last Letter of Product Code	Dimensions (in.)	Weight (lbs)	80% Charge	
			R-22 (lbs)	R-404a (lbs)
53VQ	8 $\frac{3}{4}$ x 29	40	48	40.7
54VQ	8 $\frac{3}{4}$ x 38	60	64	54.2
55VQ	9 $\frac{3}{4}$ x 38	70	80	67.6
56VQ	10 $\frac{3}{4}$ x 38	97	98	82.5
57VQ	11 $\frac{3}{4}$ x 38	124	118	99.0

MACHINE ROOM REQUIREMENTS

•The equipment room floor must solidly support the compressor unit as a live load. Ground level installation seldom presents problems, but a mezzanine installation must be carefully engineered.

•HIRU and Quad-Ventional ventilation should be 100 cfm per compressor unit horsepower. The air inlet should be sized for a maximum of 600 fpm velocity (0.5 ft² of air intake per compressor unit horsepower). HICA ventilation should be 750 to 1000 cfm with 2 to 2.5 ft² of air intake per compressor unit horsepower. The ventilation fans should cycle by thermostatic control.

• All machine room ventilation equipment must be field supplied. Check local codes for variances.

• Proper ventilation provides airflow across the compressors. Duct work may be necessary.

• Provide a floor drain for disposal of condensate that may form on the compressor unit.

• Equipment must be located in the machine room to provide enough working space for service personnel, and to meet electrical codes.

• Consult NEC National Fire Handbook particularly “Installation of Switch Boards” and “Working Space Requirements”. The figures demonstrate some suggested distances. Refer to local codes for each installation.

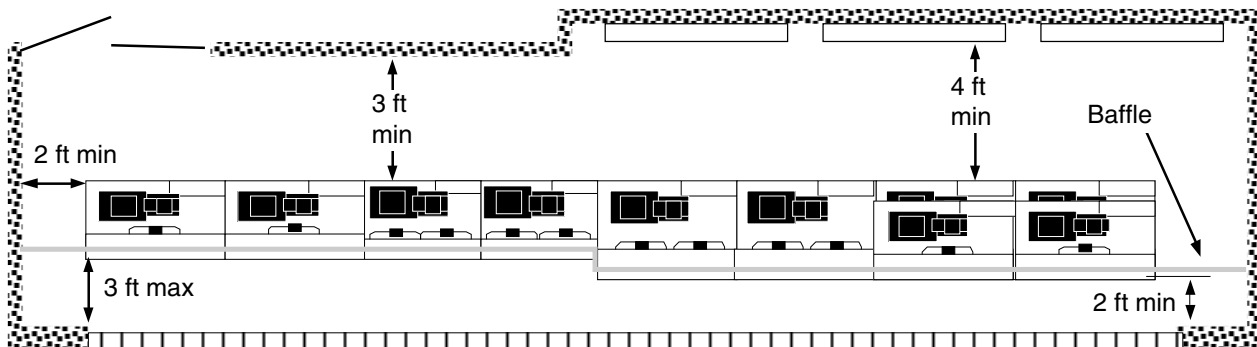
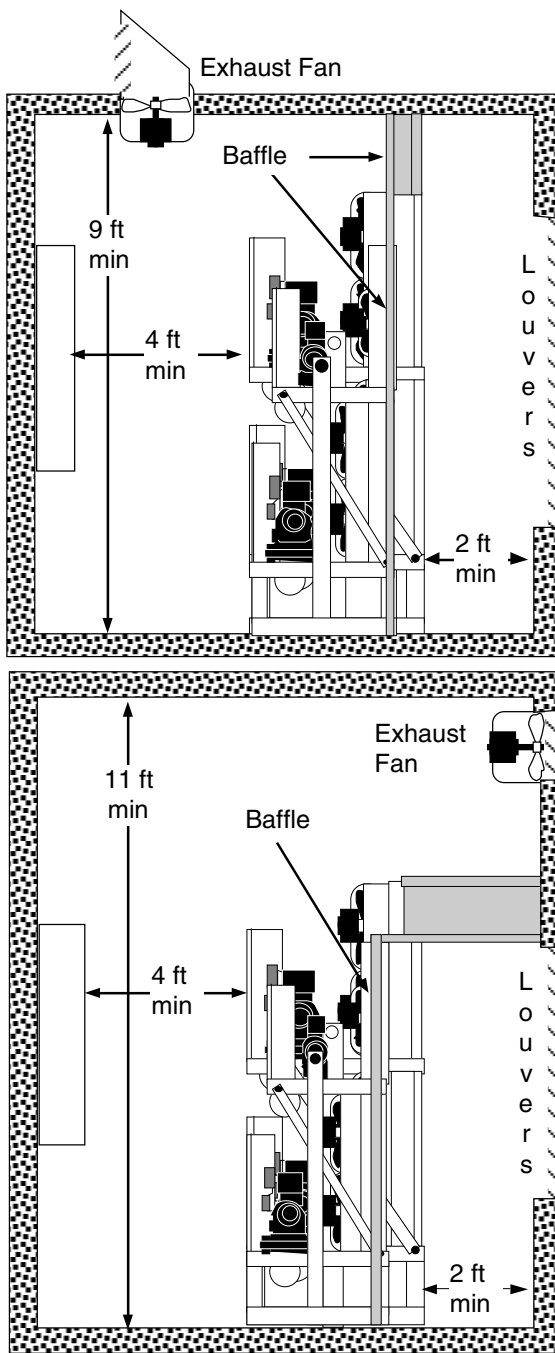

Figure 1-3 Machine Room Requirements

UNIT PLACEMENT

When setting the units, plan in relation to the rest of the equipment to be installed and existing structures. Some minimum and maximum distances are listed. **Note:** Piping equivalent is not the same as linear distance.

Minimum Allowable Distances

Between a HOCA and any vertical structure (except open chain link fence) the minimum allowable distance is 4 feet.

Between one HOCA exhaust and another HOCA intake the minimum allowable distance is 12 feet.

Between the sides of two HOCA units the minimum allowable distance is 5 feet.

On HICA and HIRU units the minimum distance between the Control Panel and a wall is 3 feet.

On HICA and HIRU units the minimum distance between the Control Panel and another live panel is 4 feet.

On HICA units the minimum distance between the Condenser Air Intake and a louvered wall is 2 feet.

Maximum Allowable Distances

When piping a suction riser the maximum vertical distance between P-traps is 20 feet.

When piping from HIRU to a Condenser, the maximum allowable piping equivalent is 100 feet.

SHIPPING BLOCK REMOVAL

Units are shipped with blocks under each compressor foot to prevent transit damage. Loosen the mounting spring nuts at least one full turn and remove the blocks.

Adjust the torque on the mounting spring nuts so that the compressor feet are 1 inch above the unit's base.

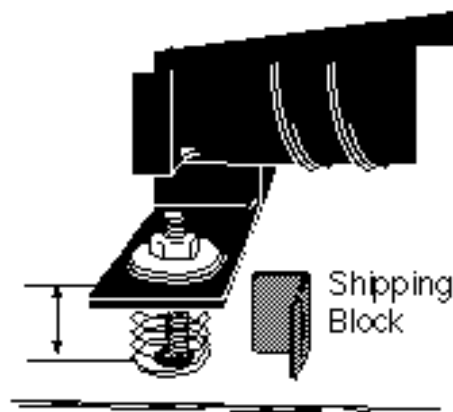
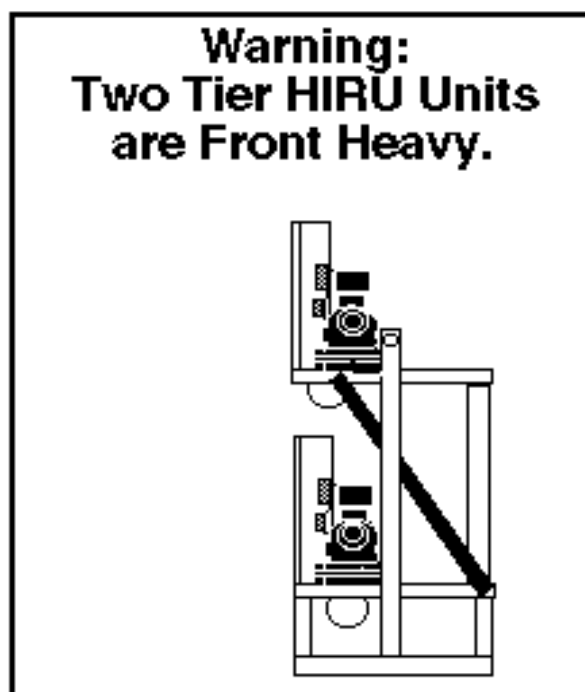

Figure 1-4 Removing Shipping Block



REFRIGERATION PROCESS

OVERVIEW

This section details the refrigeration process by tracking the refrigerant flow through the system components. Heat Reclaim, Demand Cooling and Reverse Cycle Defrost are covered here. See *Piping* for piping guidelines.

In this instruction the following constants are maintained to assist the reader.

In the diagrams refrigerant flow direction is generally clockwise.

Electrical solenoid valves carry the same initial abbreviations as in the electrical schematics.

Each specific refrigerant state and pressure maintains the same fill pattern throughout the instruction.

Vapor - hot high pressure.....

Vapor - warm high pressure.....

Liquid - warm high pressure

Vapor - cool low pressure.....

REFRIGERATION CYCLE

Beginning with the **Compressor**, vapor refrigerant is compressed into the **Discharge Line**.

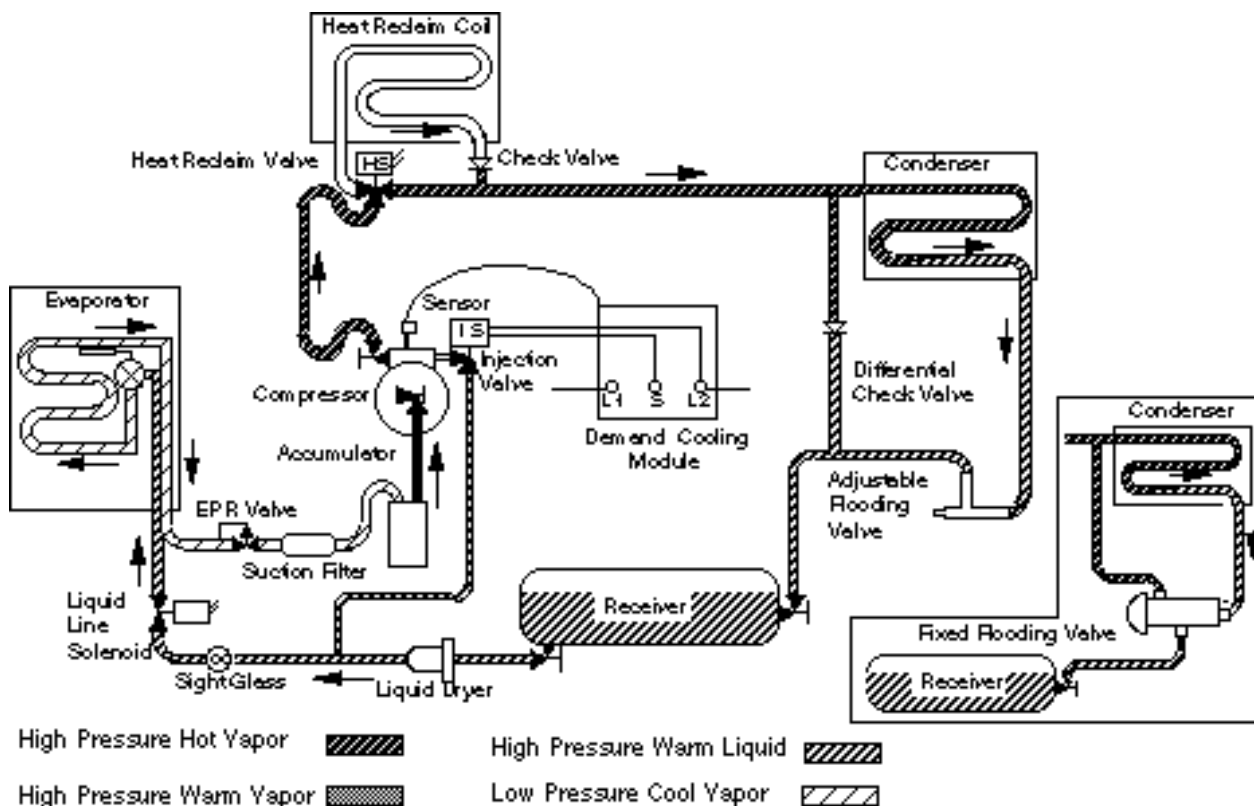

A 3-Way **Heat Reclaim Valve** (HS) directs the refrigerant to either the condenser or a Heat Reclaim Coil. When the HS solenoid is de-energized, the valve directs the refrigerant to the condenser.

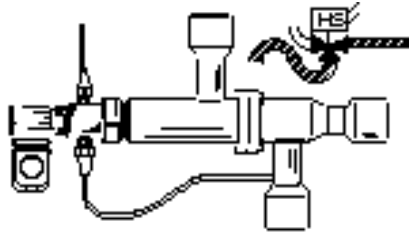

The **Condenser** discharges the unwanted heat from the system.

Low Ambient Controls include Fan Cycling (See Electrical Section), field supplied and installed louver controls (See manufacturer's manual) and **Flooding Valves**. These valves may be fixed or adjustable. The adjustable flooding valve works in parallel with a 20 pound differential check valve.

The fixed flooding valve maintains head pressure in response to a charge in its dome.

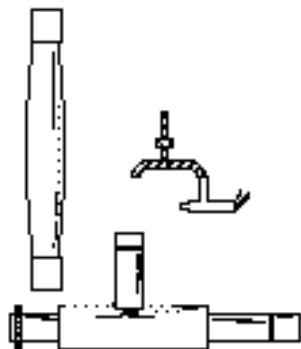
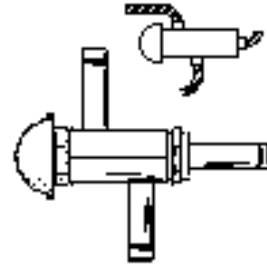

Figure 2-3 Adjustable Flooding Valve and Differential Check Valve



The **Receiver** acts as a vapor trap and supplies the Liquid Line with quality liquid refrigerant.

A **Liquid Line Drier** removes moisture and contaminants from the refrigerant.

The **Sight Glass** allows service personnel to view refrigerant flow inside the liquid line.

The **Liquid Line Solenoid Valve** closes off refrigerant supply to the evaporator.

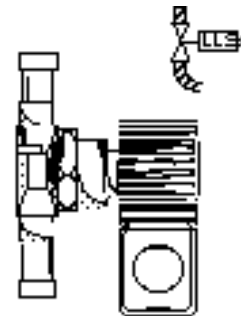

The **TEV**, located in the merchandiser, meters liquid refrigerant through its orifice to the low pressure side of the system where it evaporates, absorbing heat from the coil.

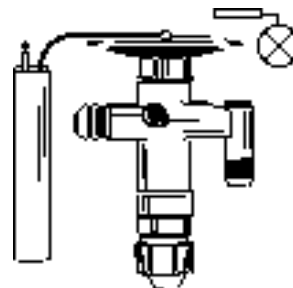

A **SORI** or **EPR Valve** (EPR) may be used to control the evaporator temperature by preventing the evaporator pressure from dropping below a set point.

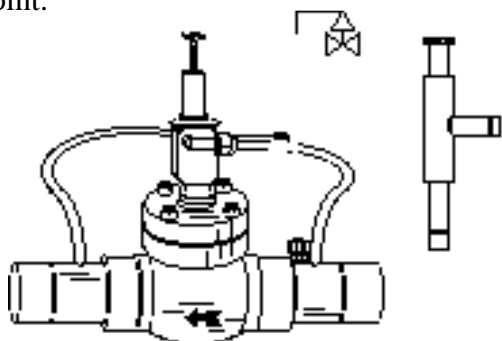

The **Accumulator** catches liquid refrigerant in the suction line and provides a means for it to boiloff before it reaches the compressor.

A **Suction Filter** is placed upstream of the compressor to remove system contaminants from the refrigerant vapor.

At critical locations along the refrigerant path, **service valves** or **ball valves** allow isolation of components.

HEAT RECLAIM VALVE

A 3-Way Heat Reclaim Valve directs the refrigerant to either the Condenser or a Heat Reclaim Coil. When the solenoid is de-energized the valve directs the refrigerant to the condenser.

The pilot valve, a check valve, is directional. When the solenoid is de-energized, the high pressure inlet is stopped and the passage between suction and valve chamber is open. When the solenoid is energized, the suction outlet is stopped and the passage between high pressure and the valve chamber is open.

"B" version of the valve has a bleed port through the drive piston to the suction manifold. The bleed port provides a vent for fluids trapped in the Heat Reclaim circuits during normal operation.

When installed with Reverse Cycle Defrost, the Heat Reclaim Valve is installed upstream of the Reversing Valve and the return enters the line to the condenser downstream of the Reversing Valve.

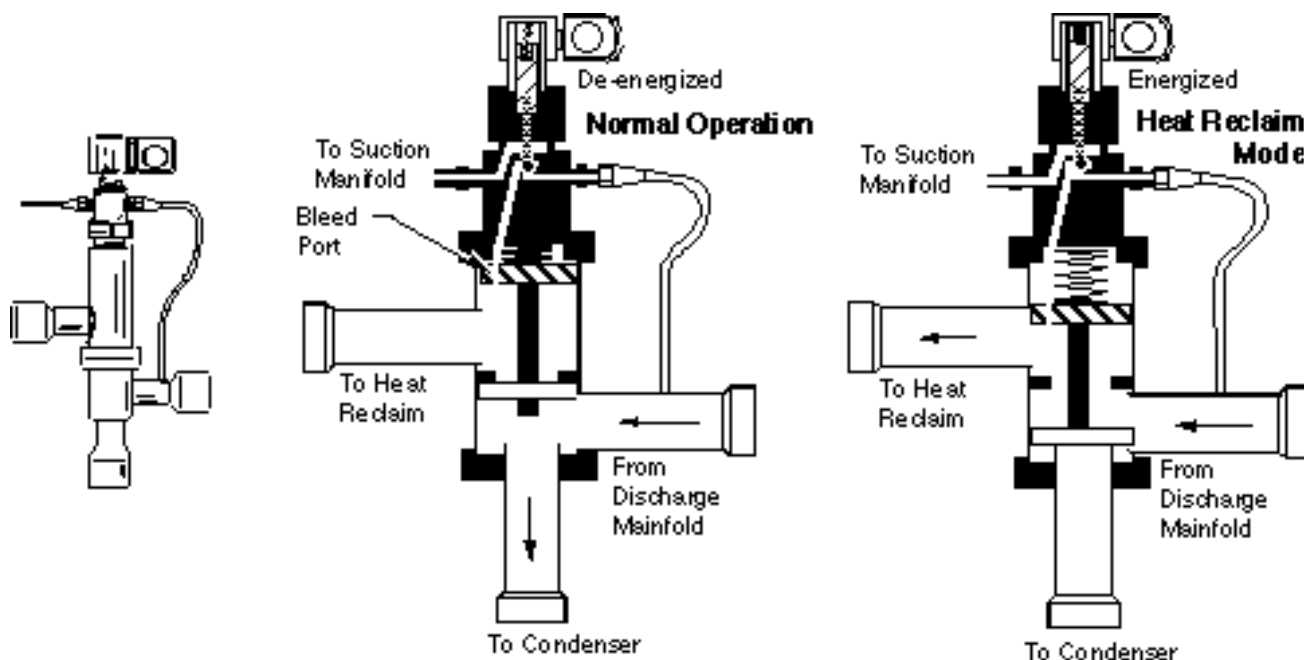

HEAT RECLAIM DESCRIPTION

Hussmann Heat Reclaim uses the heat normally discharged to the atmosphere from the condenser to provide heat to the store.

Heat reclaim is available on 3 hp and larger Hussmatic condensing units, either indoor air cooled, water cooled, or remote condensers.

Heat Reclaim is not applicable to outdoor units. It is also not normally applied to coolers or preparation areas because of their limited heat return.

Normally, the heat reclaim system will supply a large percent of the total heat required for a supermarket. But, because of the many variables involved, supplemental booster heat is advised and should be installed.

The principle behind heat reclaim is that the hot discharge gas that normally passes through the condenser is routed first through the heat reclaim coil and then to the condenser. This has a built-in safety feature so that a failure occurring in the store air handling system will not affect the refrigeration equipment.

The complete heat reclaim system includes the following:

A. Heat Reclaim Valve Kit for each HICA, HICW or HIRU unit from which heat will be reclaimed.

B. Multi-circuited Heat Reclaim Coil for each store.

C. Control System, usually either an environmental control panel or a two state heating thermostat.

Installing Heat Reclaim systems requires:

A. Location and mounting of the heat reclaim coil.

B. Piping between heat reclaim coil and condensing units with heat reclaim valve kit.

C. Electrical interconnection of the heat reclaim control to the heat reclaim valves.

LOCATION AND MOUNTING

The heat reclaim coil is installed in the duct system of the air handler and is integrated with the store heating and air conditioning systems. The coil is installed downstream of the air conditioning coil and upstream of any booster heaters involved with the duct work.

Whenever possible, air should enter the coil on the refrigerant outlet side of the coil. If necessary, for more desirable location of header stubs, the coil can be rotated such that the air flow will be reversed (into the gas inlet). However, the liquid outlet(s) must always be lower than the gas inlet(s). The heat reclaim coil must be located so the refrigerant piping neither to nor from the heat reclaim coil exceeds 100 lineal feet each, and should not be more than 3 feet below the compressor unit.

Allow sufficient space between the coil and the booster heater so radiant heat from the booster heater will not affect the coil. Duct transition must be constructed to allow even air distribution through the heating coil. The distance for a transition should be sufficient for an expansion ratio of 4:1 on the inlet side and a contraction ratio of at least 3:1 on the outlet side.

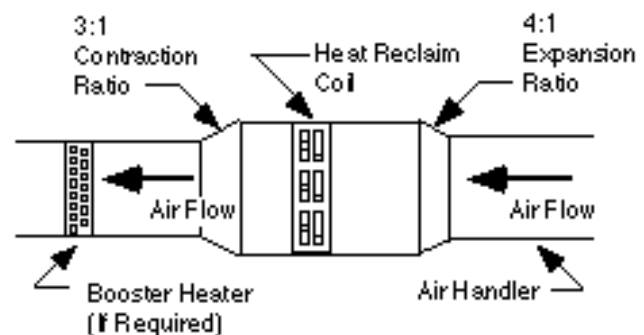

Figure 2-9 Heat Reclaim
Expansion Ratios

When heat reclaim coils are mounted in abrupt expansions downstream from the air discharges, it is very difficult to achieve even velocities across the face of the coil because air distribution is poor. If it becomes necessary to place duct

coils in this arrangement, then a 50% free air perforated plate is recommended to improve performance. This method will give good air distribution across the duct coil without significant effect on airflow rate or static pressure. The plate must be positioned at a distance from the fan outlet of 1.5 times the diameter of the fan. Any other location will not give acceptable performance.

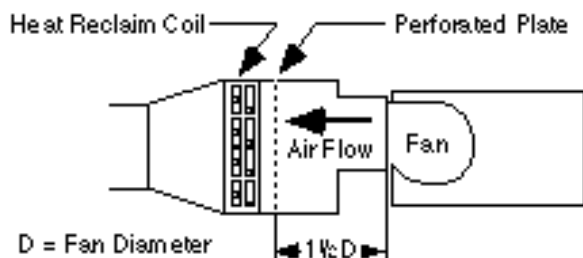

Figure 2-10 Heat Reclaim Smoothing Air Velocities

Here, the heat reclaim coil is mounted downstream from the air conditioning coil in an air handler.

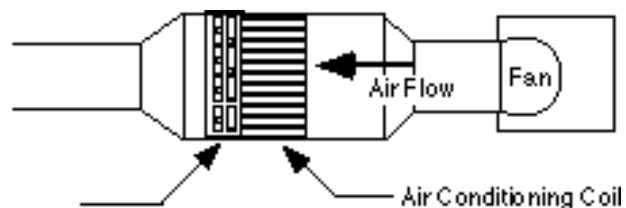

Figure 2-11 Heat Reclaim with

LOW AMBIENT CONTROLS

Adjustable Flooding Valve with Differential Check Valve

The **Adjustable flooding valve** maintains head pressure in low ambient conditions by reducing the available condensing area. When restricting liquid refrigerant flow from the Condenser, the **Adjustable flooding valve** prevents the liquid refrigerant from leaving the Condenser as fast as it is forming, so the Condenser floods with its own condensate.

During high ambient conditions, the inlet pressure on the seat disc exceeds the force of the adjusting spring and the valve stays open.

During low ambient conditions the head pressure drops. As the inlet pressure on the seat disc falls, the force of the adjusting spring pushes the seat disc toward a closed position. As the valve closes it throttles the refrigerant flow out of the condenser.

Since the Adjustable flooding valve responds to low head pressure by throttling the liquid return line to the receiver, the receiver pressure tends to drop even further. To maintain receiver pressure the adjustable flooding valve is applied with a parallel **differential check valve** requiring about 20 pressure pounds to open. If the receiver pressure drops below the condenser pressure by 20 pounds, the check valve opens directing compressor discharge vapor into the receiver to maintain sufficient high side pressure for TEV operation.

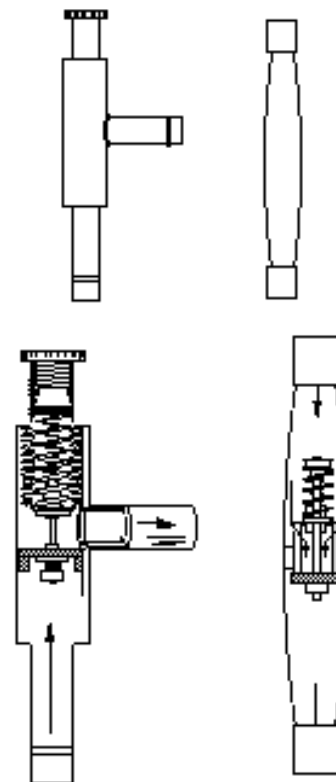

Figure 2-12 Adjustable Flooding Valve and Differential Check Valve

Fixed Flooding Valve

The **Fixed Flooding Valve** maintains head pressure in low ambient conditions by reducing the available condensing area. When restricting liquid refrigerant flow from the Condenser, the **Fixed Flooding Valve** prevents the liquid refrigerant from leaving the Condenser as fast as it is forming, so the Condenser floods with its own condensate.

During high ambient conditions the inlet pressure from the Bypass exceeds the force on the diaphragm from the pressure in the dome. The passage from the condenser inlet to the receiver outlet stays open.

During low ambient conditions the head pressure drops. As the bypass inlet pressure falls, the force on the diaphragm from the pressure in the dome pushes the seat disc toward a closed position. As the valve closes it throttles the refrigerant flow out of the condenser and opens the bypass. The opened bypass directs compressor discharge vapor into the receiver to maintain sufficient high side pressure for TEV operation.

Notes:

- The Fixed Flooding Valve is not recommended for use with fan cycling controls.
- In some installations check valves may be required to prevent migration of refrigerant during off-cycle periods.

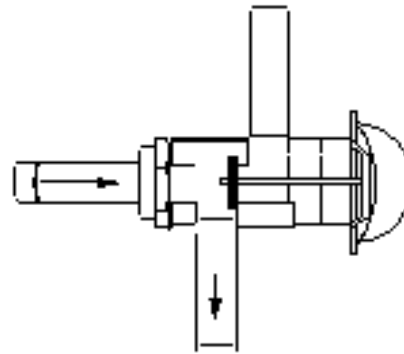

High Ambient Conditions

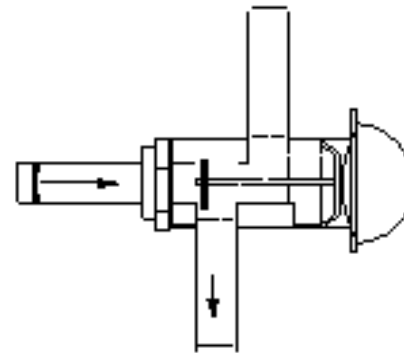

Low Ambient Conditions

LIQUID LINE SOLENOID VALVE

The Liquid Line Solenoid Valve closes off refrigerant supply to the evaporator.

When the Solenoid is de-energized, the Valve Port ① is held closed. Higher Pressure ② upstream fills the Valve Chamber ③ through the Equalizing Port ④, keeping the Valve closed.

In refrigeration the Valve Port ① opens, emptying Valve Chamber ③ faster than the Equalizing Port ④ can fill it. Higher Pressure ② upstream forces the Valve open.

Note: If a liquid line solenoid valve is used with Reverse Cycle Defrost it must be a bi-flow type. Otherwise, a check valve must be piped around the solenoid to allow reverse flow during defrost.

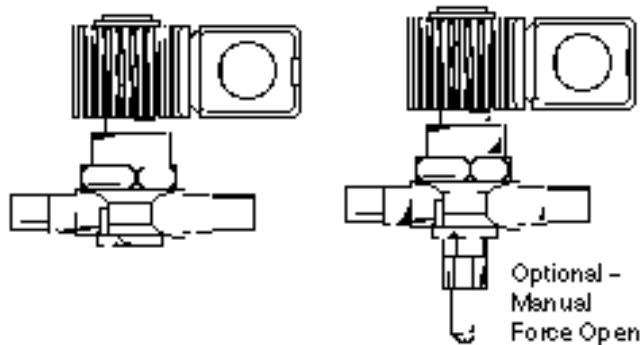
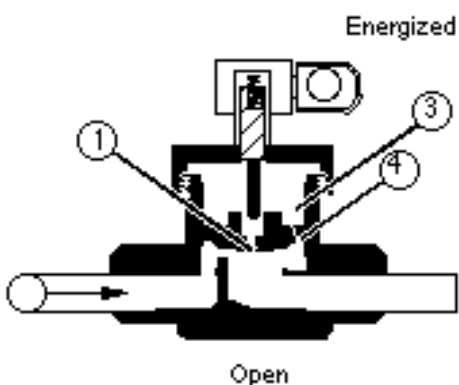
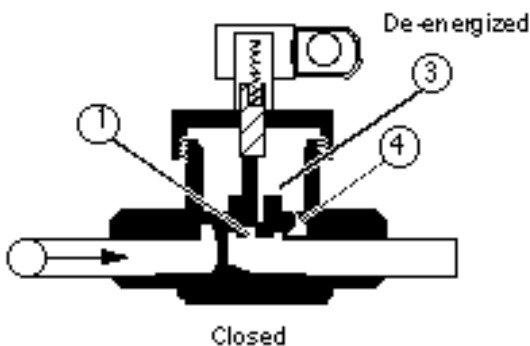
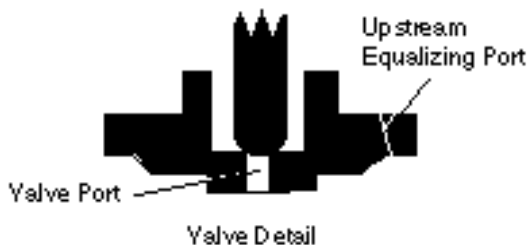

TEV

The Thermal Expansion Valve regulates refrigerant flow into the evaporator by responding to the temperature of superheated vapor at the outlet of the evaporator.

Note: With Reverse Cycle Defrost, the evaporator piping and expansion valve assembly are the same as in Koolgas merchandisers.

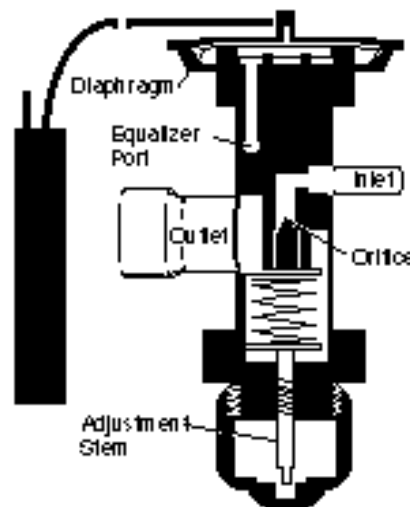
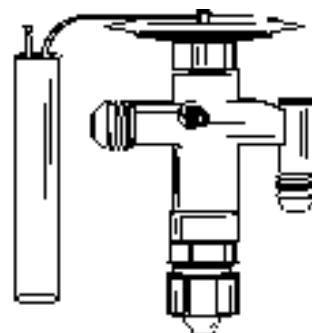

Before attempting to set a TEV be sure the merchandiser is within 10°F of its normal operating range. Attach temperature probes at both the TEV bulb location (under the clamps), and between the TEV and the evaporator Inlet.

While the valve is hunting the temperature difference between the two probes should not exceed 3-5°F. The differential may fall to zero. To reduce differential, turn the adjusting stem counter clockwise and wait at least 15 minutes before checking results.

Valve Body	Recommended Adjustment
G	½ turn
BF	¼ turn

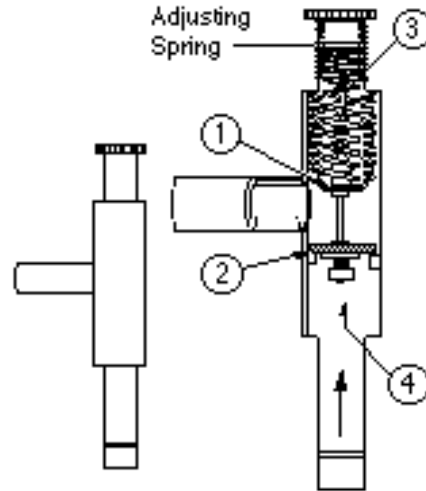
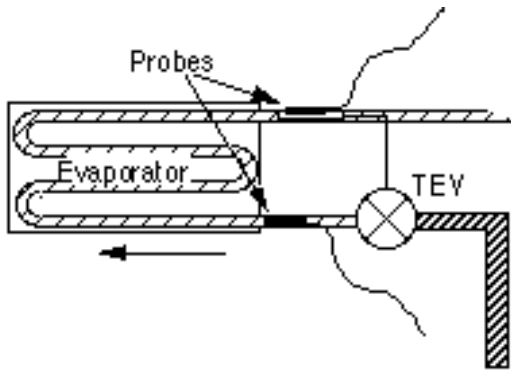

Pilot operated EPR Valves (used on some HOCA units) require an external high pressure supply to power the main piston chamber. This high pressure supply must maintain a positive differential of at least 50 psig above the down stream side of the valve. Lower pressure differentials may cause valve malfunction.

EPR VALVE

Evaporator Pressure Regulator Valves respond to upstream pressure and are used to maintain a minimum evaporator temperature. The final test for setting an EPR should always be evaporator discharge air temperature. Basically all EPR and ORI valves open on upstream suction pressure rise.

In the direct acting EPR the outlet pressure applies equal force to both the Valve Disc ② and the Spring Diaphragm ①. Since outlet pressure on the diaphragm opens the valve, and on the disc closes the valve, outlet pressure is negated as a factor in the valve operation. The two remaining forces on the valve disc are the Spring Tension ③ pushing it closed, and the Upstream Pressure ④ pressing it open.

Achieve the desired suction pressure by balancing Adjustment Spring ① against Upstream Suction Pressure ② and Fixed Pressure Counter Spring ③. As upstream pressure rises it closes the high pressure inlet to the Main Valve Chamber ④. The downstream bleed off reduces the Main Chamber pressure to the point that Piston Spring ⑤ and Upstream Pressure ⑥ open the main valve.

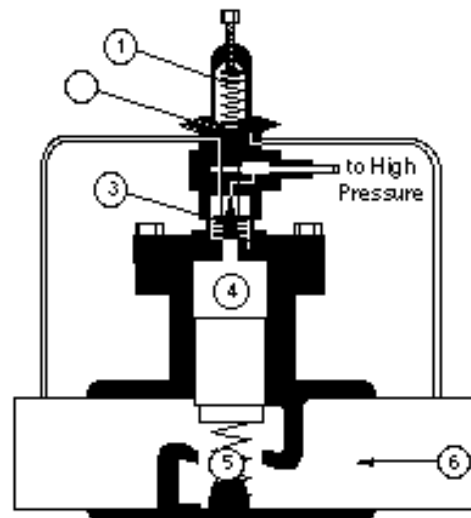

CPR VALVE

There are basically two designs of Crankcase Pressure Regulators used. On smaller units a direct acting type is sufficient. For larger units a pilot operated valve is used because of the volume of refrigerant flow.

In the Direct Acting CPR the inlet pressure applies equal force to both the Valve Disc ② and the Spring Diaphragm ①. Since inlet pressure on the diaphragm closes the valve, and on the disc opens the valve, inlet pressure is negated as a factor in the valve operation. The two remaining forces on the valve disc are the Spring Tension ③ pushing it open, and the Downstream Pressure ④ pressing it closed.

When the downstream pressure exceeds the adjusting spring force, the valve closes.

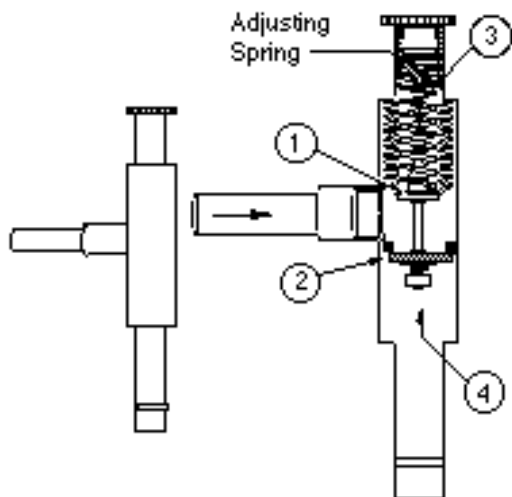

In the Pilot Operated CPR Valve the Downstream Pressure ① fills the Chamber ② just below the the Adjusting Spring Diaphragm ③. When the Downstream Pressure falls below the force of the Adjusting Spring, the Pilot Port ④ opens allowing upstream pressure into the Valve Chamber. As the Valve Chamber fills the valve opens. When the Downstream Pressure exceeds the Spring Force the Pilot Port is closed.

The Valve Chamber empties through Bleed Ports and the Closing Spring pulls the main valve closed.

When the downstream pressure exceeds the adjusting spring force, the valve closes.

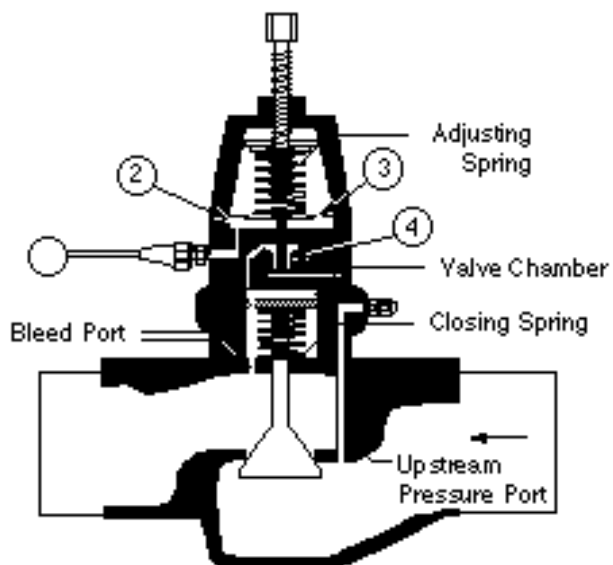

DEMAND COOLING

The Demand Cooling System is designed to inject saturated refrigerant into the suction cavity when the compressor internal head temperature exceeds 292°F. Injection continues until the temperature is reduced to 282°F. If the temperature remains above 310°F for one minute the control shuts down the compressor. After correcting the cause of shutdown, manual reset is required.

Demand Cooling is available only on Low Temperature Discus compressors using R22 refrigerant.

The System Parts

- Temperature Sensor
- Control Module
- Injection Valve

The Temperature Sensor employs a Negative Temperature Coefficient (NTC) Thermistor to provide signals to the Control Module. The NTC resistance drops on temperature rise.

Temperature °F	Approximate Ω Reading
77	90,000
282	2,400
292	2,100
310	1,700

Probe test readings between 100,000 Ω and 1,600 Ω usually indicate an operating probe.

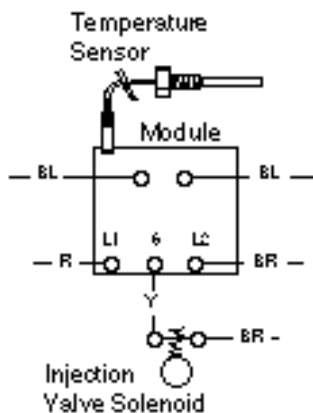
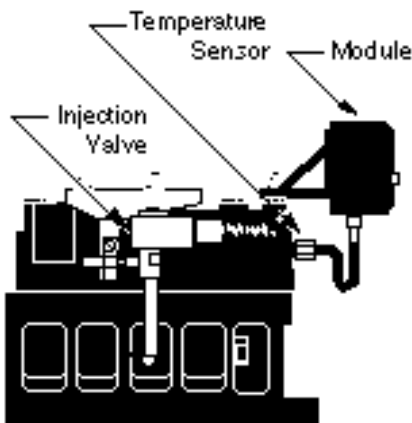

Figure 2-21 Demand Cooling Components

Component Testing

Remove power to the system. Unplug the Temperature Sensor from the Module. The Sensor should ohm out between 1,600 Ω and 100,000 Ω .

Leave the Sensor unplugged and restart the system. There should be **no** voltage between terminals "S" and "L2" on the Module. The inlet and outlet sides of the Injection Valve should feel the same temperature. After one minute the alarm relay should trip. Remove power to the system. Press the manual reset on the Module.

Using a small piece of wire jump the Sensor circuit at the female plug in the Module. Restart the system. There should be **voltage** between terminals "S" and "L2" on the Module. The outlet side of the Injection Valve should feel colder than the inlet side. After one minute the alarm relay should trip. Remove power to the system. Press the manual reset on the Module.

Remove the jumper wire and plug in the Temperature Sensor.

Restart the System.

Alarm Circuit

The Alarm Circuit has three terminals in the Control Module.

- "L" —Common
- "M" —Normally Closed
- "A" —Normally Open

"L" and "M" are wired into the compressor control circuit so an alarm condition removes the compressor from the line and power to the Module. A manual reset is required to call attention the alarm condition.

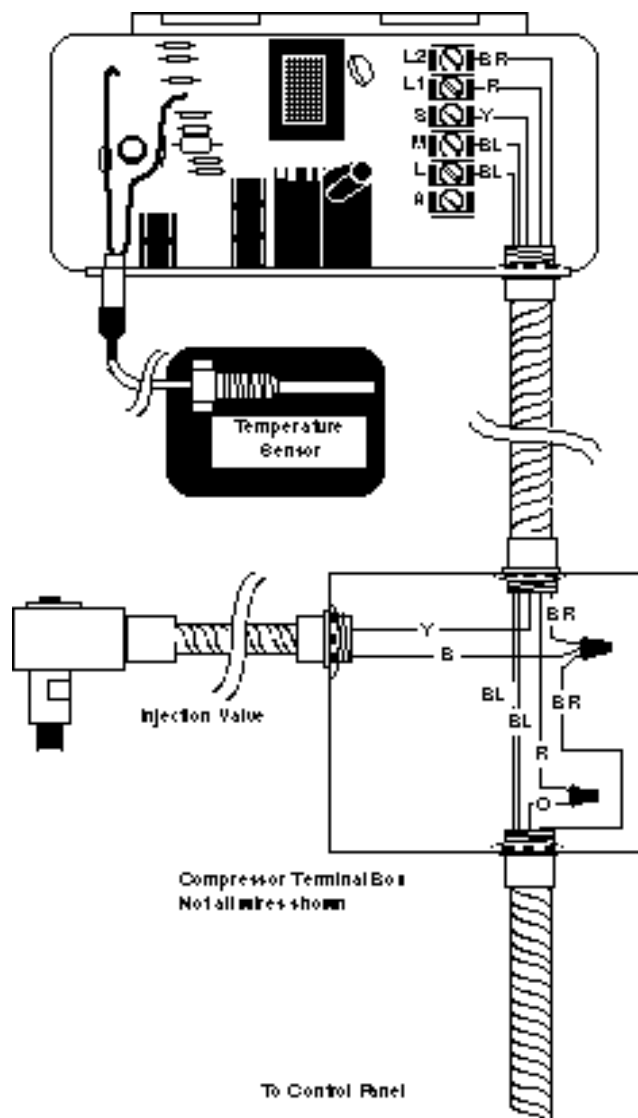

Figure 2-23 Demand Cooling Alarm Connections

Alarm Relay

The Alarm Relay is activated after a one minute delay under the following three conditions:

- When compressor discharge temperature exceeds 310°F.
- A shorted circuit or very low Thermistor Resistance.
- An open circuit or very high Thermistor Resistance.

Operational Notes:

Demand Cooling does NOT replace head cooling fans which are still required on low temperature applications.

Temperature Sensor cable must not touch any hot surfaces or the cable will be damaged.

SPECIAL NOTES REGARDING COPELAND SCROLL COMPRESSORS

Liquid Injection

Copeland's Midpoint Liquid Injection is standard on all low temperature (ZF) scroll compressor models. A precision sized capillary tube mounted on the compressor is fed from the unit liquid line after the drier. The refrigerant flow to the capillary tube is controlled by a solenoid valve which closes when the compressor is not running. On the 3- to 6-HP models, a current sensing relay is included to close the solenoid if the compressor shuts off on internal protection.

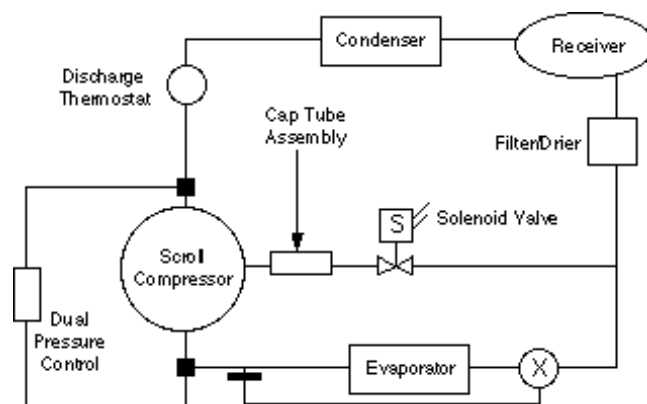

Figure 2-24 Liquid Injection Schematic

Oil Level Monitoring

The oil level in scroll compressors is monitored by the Sporlan Trax-Oil device. On other applications the Trax-Oil is used to regulate the flow of oil back to the compressor, but on Conventional Units the Trax-Oil is used as a compressor protective device only. The Trax-Oil has a sightglass with a float to indicate the actual oil level in the compressor. When the oil level drops below 1/2 sightglass for more than 120 seconds, the Trax-Oil unit will open the compressor control circuit.

Crankcase Heater

A crankcase heater is required on all outdoor scroll compressor units.

Discharge Line Thermostat

A discharge line thermostat is standard on all Copeland scroll compressors 6 HP and smaller.

Accumulator

Due to the smaller footprint of the scroll compressors, factory installed accumulators will now be available as an option on these units.

Phase Monitor

A phase monitor is standard on the scroll compressor units. It is a requirement that the scroll operate with the correct direction of rotation, so a monitor is needed to maintain correct phase orientation.

REVERSE CYCLE DEFROST

Reverse Cycle Defrost may be applied to HICA units. The 4-Way Reversing Valve provides a two line gas defrost by switching the functions of the evaporator and the condenser during defrost. The pilot valve on the Reversing valve is a direct acting reversing valve. The valve is installed so that solenoid failure leaves the unit in refrigeration mode.

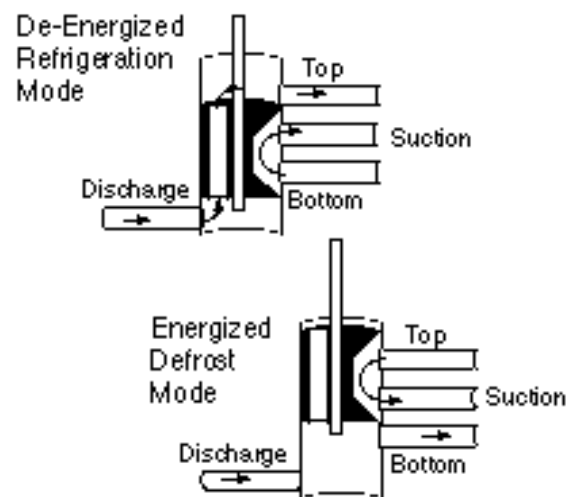

Figure 2-25 Pilot Valve Operation

Notes:

- If a liquid line solenoid valve is used with Reverse Cycle Defrost it must be a bi-flow type.
- If a fan cycling control is used on the condenser, a bypass relay keeps the fans running during defrost.
- With Heat Reclaim the Valve is installed upstream of the Reversing Valve and the return enters the line to the condenser downstream of the Reversing Valve. Heat Reclaim is locked out during defrost.
- 7½ through 15 hp units use two parallel bi-flow driers. 20 hp and above use a standard drier and check valve together in parallel with a second check valve for reverse flow.

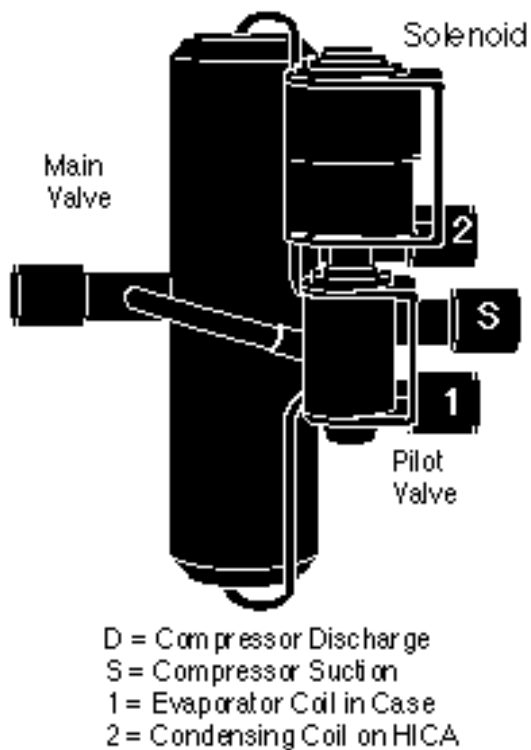

Figure 2-26 Reversing Valve Connections

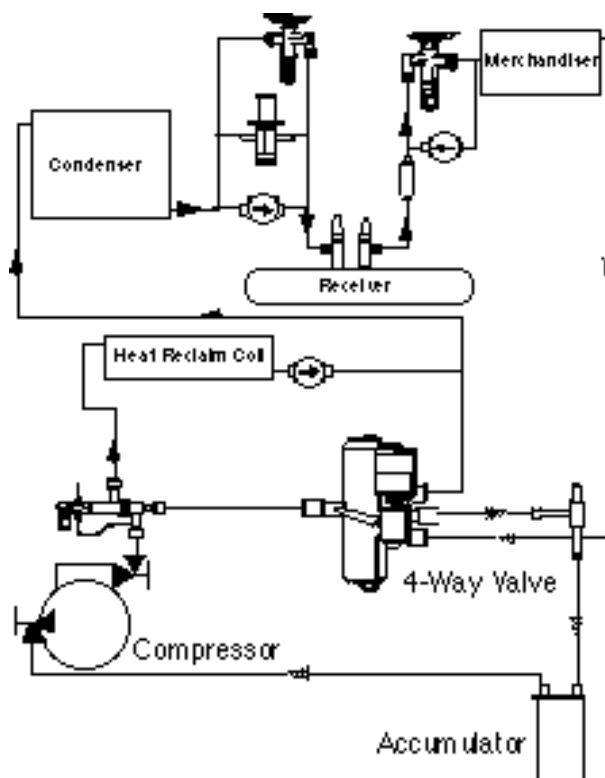
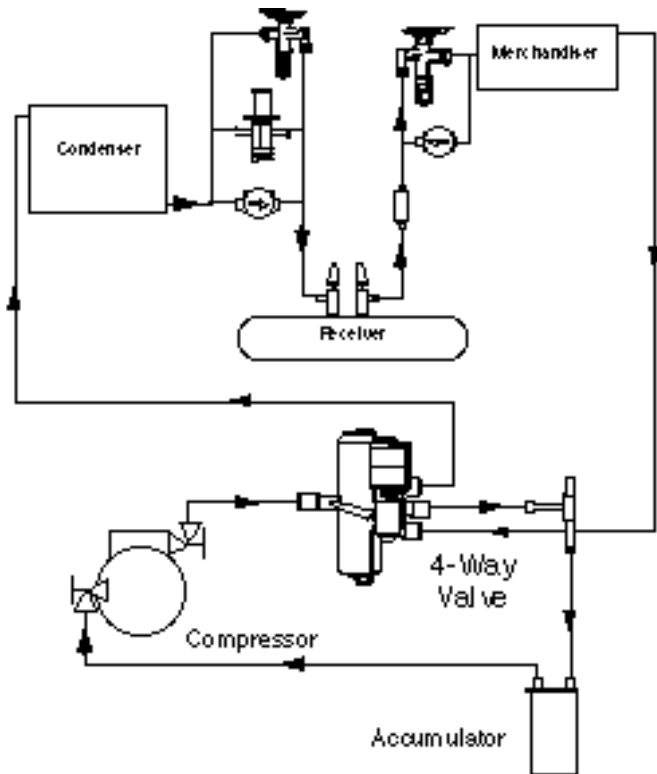
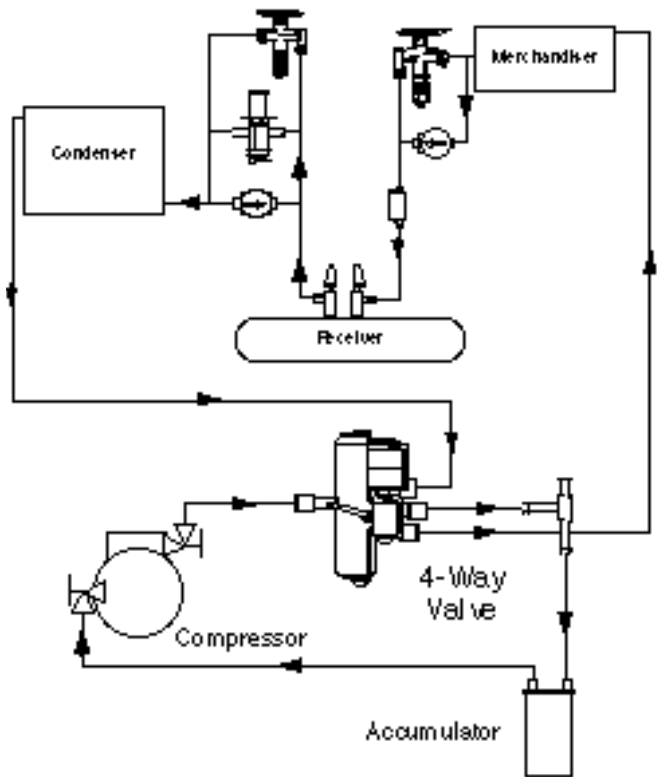
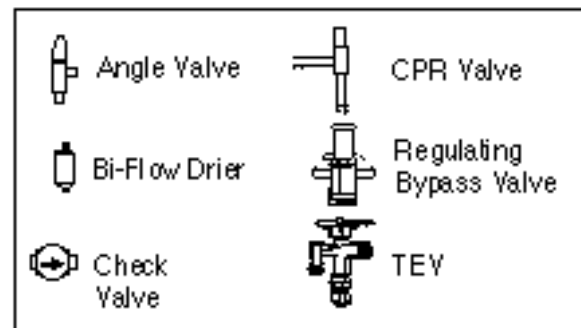
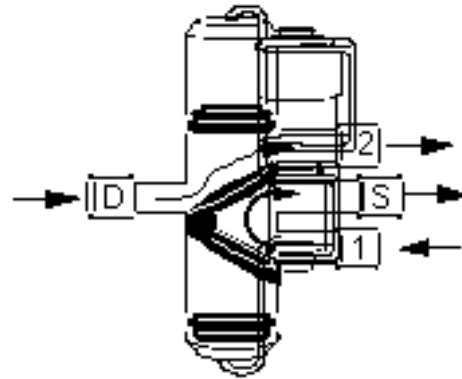

Figure 2-27 Heat Reclaim with Reverse Cycle Defrost



**Custom
Conventional
Reverse Cycle Defrost**

Refrigeration Mode



Defrost Mode

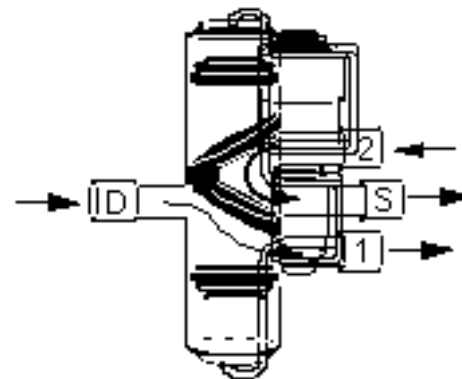

Figure 2-28 Reverse Cycle Defrost—Refrigeration and Defrost Modes

TEMPERATURE CONTROL

Varied applications, temperature ranges, piping runs, machine selection and placement, along with the customer needs, all affect the selection of temperature control devices. Five methods of controlling temperature are listed below along with advantages and disadvantages of each method.

METHOD	ADVANTAGES	DISADVANTAGES
Thermostat controlling Compressor Motor Contactor	<ul style="list-style-type: none"> + Quick compressor response + Less short cycling than with pressure control + Thermostat is part of compressor control circuit 	<ul style="list-style-type: none"> – No positive refrigerant shutoff—possible liquid migration to suction line (not recommended for long off cycles) – Requires stat to control panel wiring – Thermostat voltage is the same as the control panel voltage
Thermostat controlling Liquid Line Solenoid on Compressor Unit (Compressor run controlled by pressure)	<ul style="list-style-type: none"> + Reduces liquid migration to suction line by pumping down at cycle end + Same solenoid acts for defrost pumpdown + Convenient for installation and service + Thermostat is part of control panel circuit 	<ul style="list-style-type: none"> – Slower compressor response – Requires stat to control panel wiring – Compressor may short cycle – Thermostat voltage is the same as the control panel voltage – Oil foaming during pumpdown
Thermostat controlling Liquid Line Solenoid at Evaporator (Compressor run controlled by pressure)	<ul style="list-style-type: none"> + Reduces liquid migration to suction line by pumping down at cycle end + Same solenoid acts for defrost pumpdown + Requires <u>no</u> stat to control panel wiring + Quick evaporator response + On walk-ins the circuit may be used with a door switch 	<ul style="list-style-type: none"> – Slower compressor response – Compressor may short cycle – Oil foaming during pumpdown
*EPR Valve with Thermostat	<ul style="list-style-type: none"> + Provide the most consistent humidity and temperature control 	<ul style="list-style-type: none"> – Decrease compressor efficiency – May increase compressor short cycling during low load conditions without unloader
Low Pressure Control only	<ul style="list-style-type: none"> + Simple control panel + Suitable for non-critical Medium Temperature applications 	<ul style="list-style-type: none"> – Suction line must be run so ambient conditions do not affect evaporator performance – Unsuitable for products requiring a narrow temperature range to maintain shelf life – Unsuitable for HOCA or HIRU in low ambient application – May increase compressor short cycling during low load conditions without unloader – During low load and low ambient conditions refrigeration may continue below desired cutout temperature

*EPR Valves are required as primary temperature control with a thermostat as secondary control for all service deli and meat merchandisers.

COMPONENT PIPING

OVERVIEW

This section deals with the information necessary for installing the refrigeration lines for Conventional Units. The Conventional Units are piped as completely as practical at the factory. Field piping requires only interconnection of the major components and the refrigerators.

Use only clean, dehydrated, sealed refrigeration grade copper tubing. Use dry nitrogen in the tubing during brazing to prevent the formation of copper oxide. All joints should be made with silver alloy brazing material, and use 35% silver solder for dissimilar metals.

REFRIGERATION LINE RUNS

Liquid lines and suction lines must be free to expand and contract independently of each other. Do not clamp or solder them together. Run supports must allow tubing to expand and contract freely. Plan proper pitching, expansion allowance, and P-traps at the base of all suction risers. Use long radius elbows to reduce line resistance and breakage. Avoid completely the use of 45° elbows. Install service valves at several locations for ease of maintenance and reduction of service costs. These valves must be UL approved for 450 psig minimum working pressure.

WARNING

Always use a Pressure Regulator on the nitrogen tanks.

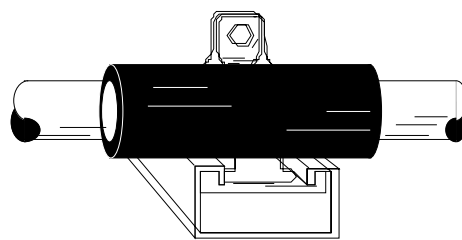

Support Detail

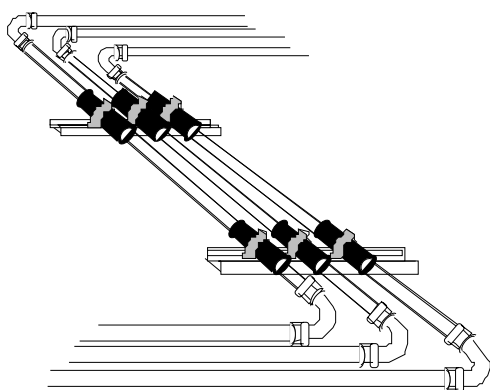

Floor Run

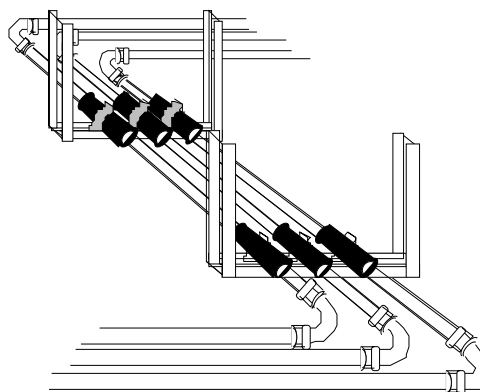

Ceiling Run

Figure 3-1 Supporting Refrigeration Lines

Through Walls or Floors

Refrigeration lines run through walls or floors must be properly insulated. Avoid running lines through the refrigeration cases. When this is done, the lines must be adequately insulated—Armaflex or equivalent.

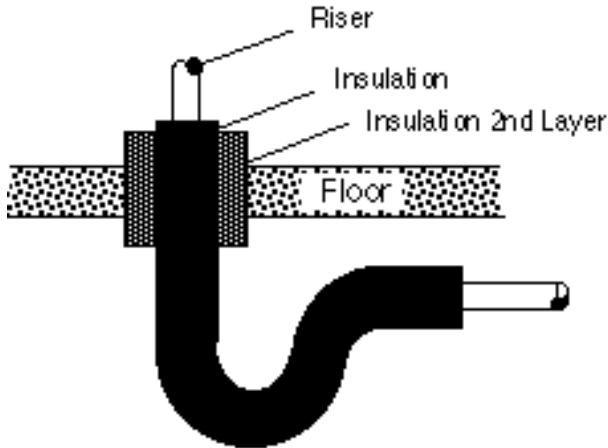

From Machinery to Solid Object

When mounting lines from machinery to a solid object, allow line freedom for vibration to prevent metal fatigue.

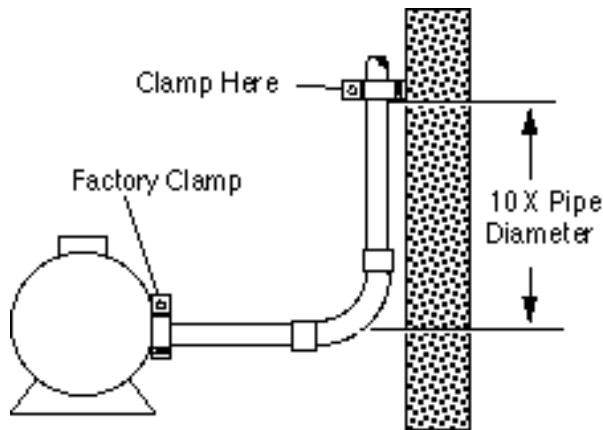

P-Trap Construction

A P-Trap must be installed at the bottom of all suction risers to return oil to the compressors.

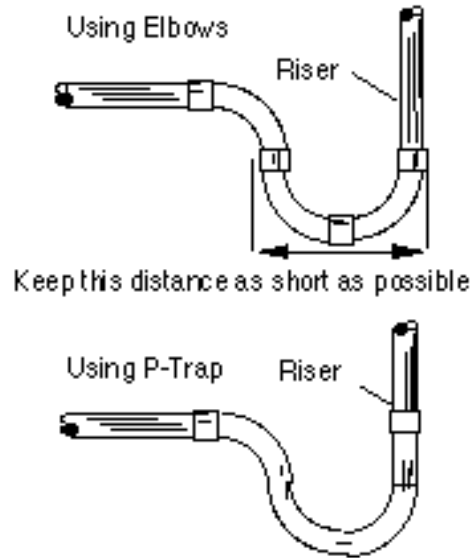

Reduced Riser

When a reduced riser is necessary, place the reduction coupling downstream of the P-Trap.

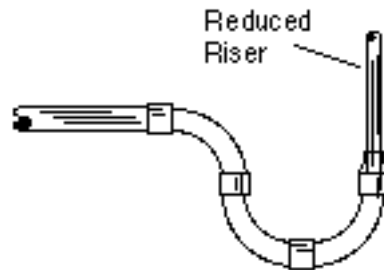

Factory Supplied Stubs

Stub sizes provided do not automatically correspond to the line sizes necessary. It is the installer's responsibility to supply reduction couplings.

Protecting Valves and Clamps

When brazing near factory installed clamps or valves be sure to protect them with a wet rag to avoid overheating.

Connecting Remote Condenser

- Discharge Line will be routed directly to the condenser inlet stub with a purge valve at the highest point.
- Liquid Return Line will be pitched downstream, and provide trapless drainage to the receiver.

WARNING
Vent the Receiver Safety Relief Device properly.

Purge Valve Location

The purge valve will be installed at the highest point of an inverted P-trap, with at least a 3-inch rise. (Use with approved recovery vessel.)

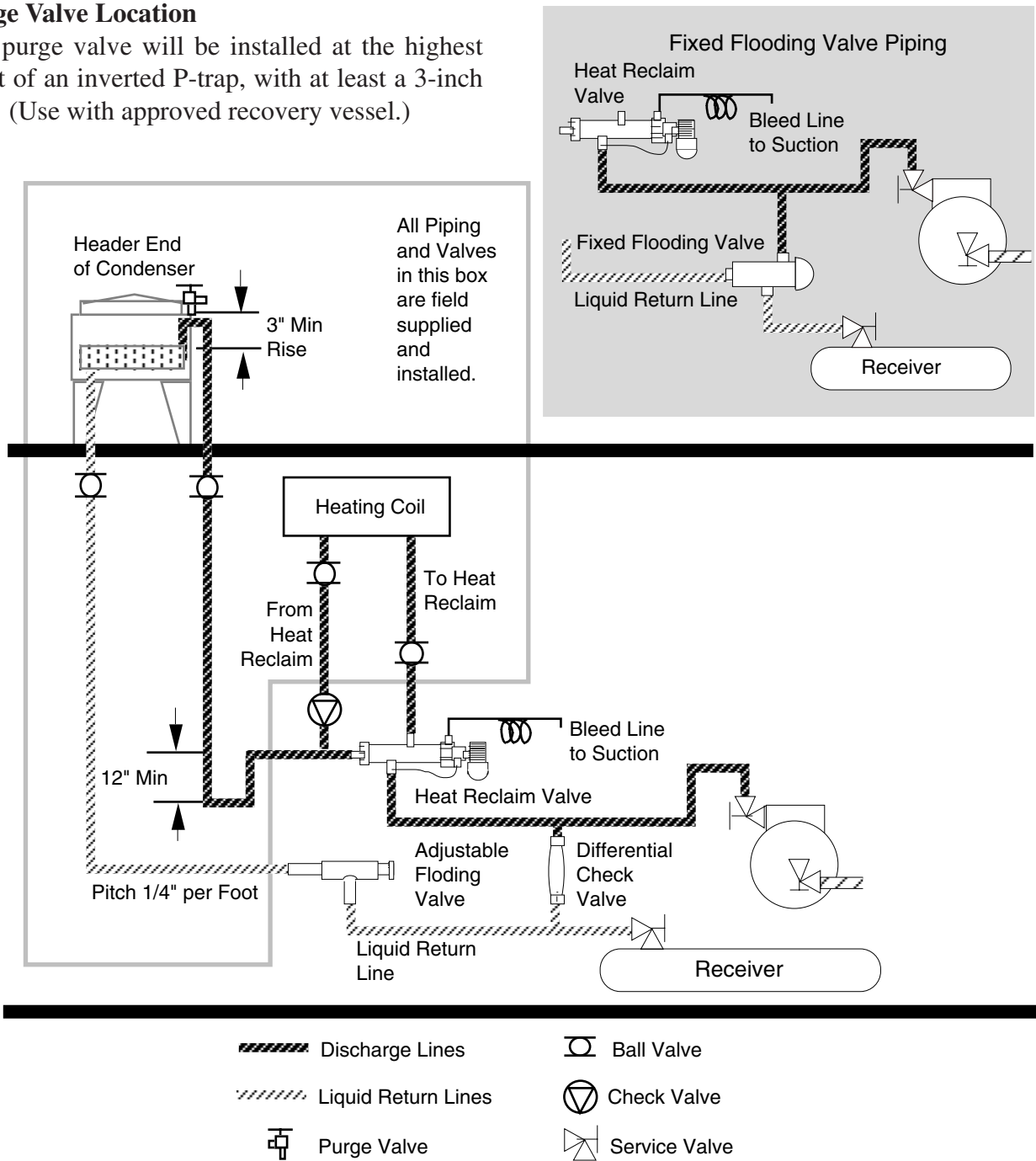
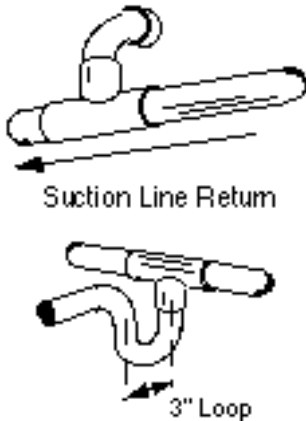

Figure 3-6 HIRU to Condenser Piping

MERCHANDISER PIPING

Suction Line

- Pitch in direction of flow.
- May be reduced by one size at one-third of case run load and again after the second third. Do not reduce below evaporator connection size.
- Suction returns from evaporators enter at the top of the branch line.



Liquid Line

Offtime and Electric Defrost

- May be reduced by one size after one-half the case load run. Do not reduce below evaporator connection size.
- Take-offs to evaporators exit the bottom of the liquid line. Provide an expansion loop for each evaporator take-off. (Minimum 3 inch diameter.)

Reverse Cycle Defrost

- Merchandisers on Reverse Cycle Defrost are piped and equipped like Koolgas cases.
- Maximum of 6 evaporators per Unit.
- Increase the liquid line size inside the case by two sizes.

Line Size	In Case Size
1/2	7/8
5/8	1 1/8
3/4	1 3/8
1 1/8	1 5/8
1 3/8	2 1/8

- Take-offs to evaporators exit the bottom of the liquid line. Provide an expansion loop for each evaporator take-off. (Minimum 3 inch diameter.)

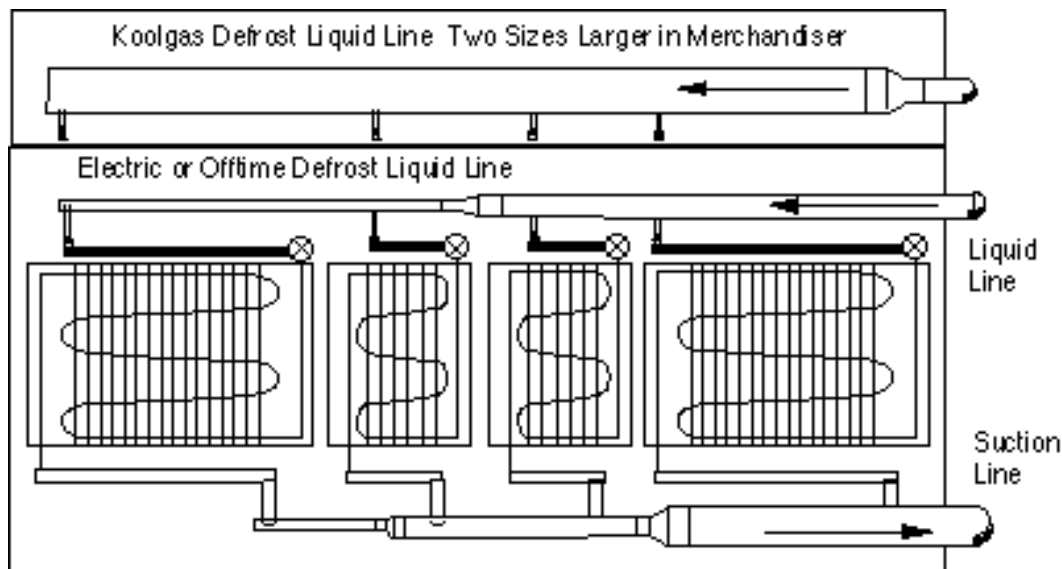

Field Connection of Heat Reclaim

Each circuit of the heat reclaim coil is tagged to correspond with a specific condensing unit and must be connected only to that unit.

The supply and return lines are to be installed as shown in Figure 3-6.

SPECIAL PIPING FOR OPEN ROOMS

An open preparation room allows heat infiltration from the rest of the store at a rate which may jeopardize total refrigeration performance. To protect the refrigeration system, open preparation room evaporators must be piped with a Crankcase Pressure Regulating Valve (CPR).

The CPR is field installed in the suction line(s) from the evaporator(s). The installer is responsible for proper adjustment of the Valve.

RUN LENGTHS AND EQUIVALENT FEET

When figuring run lengths, angle valves and elbow 90° are figured as additional straight pipe. The following chart gives equivalent lengths for these components.

Tubing Size	Angle Valve	Long Radius Elbow 90°
½	6	1.0
5⁄8	7	1.2
7⁄8	9	1.4
1 ¼	12	1.7
1 ½	15	2.3
1 ¾	18	2.6
2 ¼	24	3.3
2 ½	29	4.1
3 ¼	35	5.0
3 ½	41	5.9
4 ¼	47	6.7

Table 3-1 Equivalent Feet for Angle Valve and Elbow 90°*
**ASHRAE 1994 Refrigeration Handbook*

INSULATION

For merchandisers and unit coolers with **GAS DEFROST**:

The suction and liquid lines should NOT contact each other and should be insulated separately for a minimum of 30 ft from the merchandiser.

For merchandisers and unit coolers with **OTHER** than gas **DEFROST**:

The suction and liquid lines should be clamped or taped together and insulated for a minimum of 30 ft from the merchandiser.

FOR ALL merchandisers and unit coolers:

Additional insulation for the balance of the liquid and suction lines is recommended wherever condensation drippage is objectionable or the lines are exposed to ambient conditions.

ELECTRICAL

OVERVIEW

The scope of this section is limited to main field wiring connections, and to the control panel.

The standard Custom Conventional Unit is available wired for 208-230/3/60 or 460/3/60 compressors. In either case, the control circuit is 208-230V.

Quad-Ventionals with 208V compressors have a single point connection. With 460V compressors, two single point connections are used, one for the compressors and one for the control and defrost circuits.

Refer to the serial plate located on the control panel to determine wire size (MCA) and over-current protection (MOPD).

FIELD WIRING

Unit components are wired as completely as possible at the factory with all work completed in accordance with the National Electrical Code (NEC). All deviations required by governing electric codes will be the responsibility of the installer.

The lugs on the circuit breaker package in the control panel are sized for copper wire only, with 75° C THW insulation. All wiring must be in compliance with governing electrical codes.

For 208-230/3/60 Compressor Units:

To each Unit provide
one 208-230/3/60 branch circuit

For 460/3/60 Compressor Units:

To each Unit provide
one 460/3/60 branch circuit
one 208-230/3/60 branch circuit

WIRING GUIDELINES BASED ON VARIOUS COMPONENTS

Check the store legend for components requiring electrical circuits to either the compressor unit or the defrost control panel.

These include:

- Defrost Termination Thermostat
- Thermostat controlling a Motor Contactor

All thermostat and temperature sensor wires should be sized for pilot duty at 120VA 120VAC. Run a 2-wire circuit for each system using either control listed above.

Unit Cooler Fan Wiring

Provide a 120/1/60 fused power supply for each cooler. (Check the store legend to see if 208-230/1/60 is required at this location.) 208V for power can be picked up from the time-clock or an optional breaker/contactors kit.

Evaporator Mounted Liquid Line Solenoid

Power for a liquid line solenoid in the case can be picked up from the fan circuit. (Check fan motor and solenoid voltages first.)

Cooler Door Switch Wiring

Check the store legend for door switch kits (M115 or M116). The switch must be mounted to the cooler door frame, and must be wired to control the field installed liquid line solenoid and the fan circuit. For Reverse Cycle Defrost applications, Kit M116 includes a check valve to bypass the liquid line solenoid valve.

Sizing Wire and Overcurrent Protectors

Check the serial plate for Minimum Circuit Ampacity (MCA) and Maximum Overcurrent Protective Devices (MOPD). Follow NEC guidelines.

Defrost Controls

The basic defrost circuits are shown on the wiring diagrams in this section. These circuits may be repeated and/or intermixed in one store.

Other Controls

When other controls are used, refer to the manual included with that control.

ABOUT THESE ELECTRICAL DIAGRAMS

All diagrams show the electrical system DE-energized and in refrigeration mode. Diagrams emphasize individual circuit continuity and logic. They aid troubleshooting and testing by identifying point-to-point connections. Color coding wires allows easy transfer to the control panel. The diagrams normally move from left to right so the user can "read" the series of components and their terminals which make up a circuit.

Generally, in a control circuit the loads are limited to coils, lights, and bells. By identifying one control circuit load and "reading" the schematic to the load, the sequence of operation becomes obvious. Troubleshooting that circuit then breaks into test point terminals. Take only one circuit at a time.

Important Note:

The diagrams in this section show circuit logic. They are **not intended** for troubleshooting or design work. For Unit Cooler fan power, electric defrost sub circuit balance, and other location specific circuits refer to the schematics on control panels or contact Hussmann Engineering.

DEFROST TIMERS

Generally, one of four time clocks will be used on a Conventional Unit for defrost control. Each is used because it fills the needs of a particular application.

8145 Indoor Clock

APPLICATIONS

Temperature Range-	Medium Low
Types of Defrost-	Electric Reverse Air Off-Time Reverse Cycle
Types of Termination-	Time Temperature

SEQUENCE OF OPERATION

On call for defrost contacts 1 - 3 close and 2 - 4 open. On call for termination contacts 1 - 3 open and 2 - 4 close.

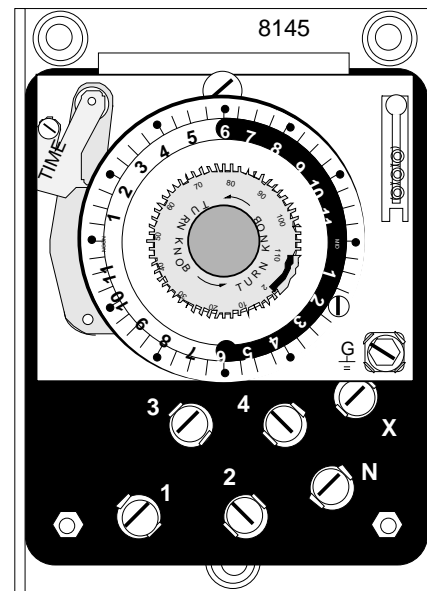
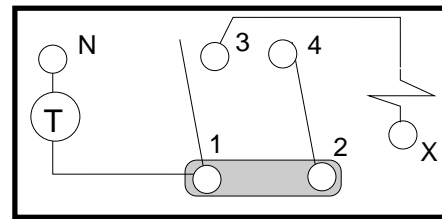

Figure 4-1 8145 Timer

8245 Indoor Clock

APPLICATIONS

Temperature Range- Medium
Low
Types of Defrost- Electric
Reverse Air
Off-Time
Types of Termination- Pressure

SEQUENCE OF OPERATION

On call for defrost contacts 1 - 3 close and 2 - 4 open. On call for termination contacts 1 - 3 open and 2 - 4 close.

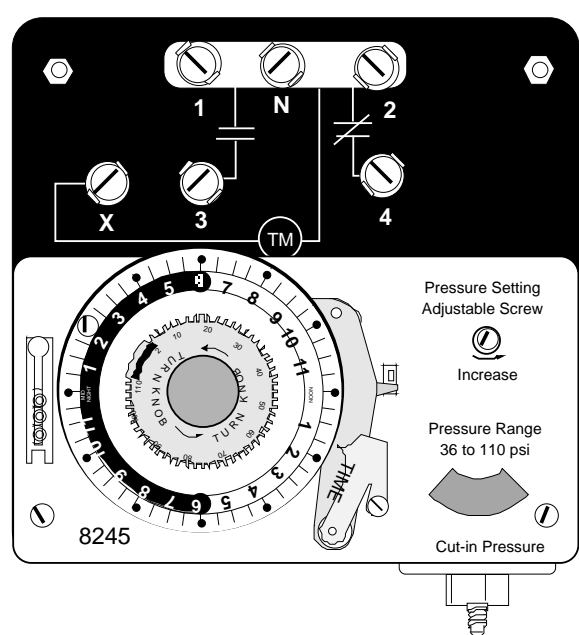
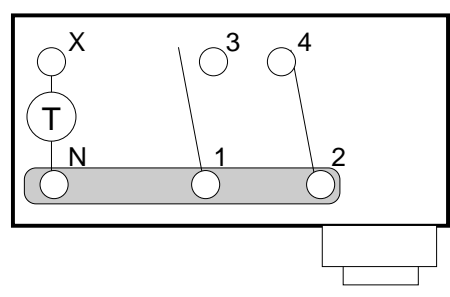

Figure 4-2 8245 Timer

A633 Outdoor Clock

APPLICATIONS

Temperature Range- Medium
Low
Types of Defrost- Electric
Reverse Air
Off-Time
Types of Termination- Time
Temperature

SEQUENCE OF OPERATION

On call for defrost contacts 3 - 1 open. Four minutes later contacts 2 - 4 open and 3 - N close. On call for termination contacts 3 - N open and 3 - 1 close, contacts 2 - 4 close.

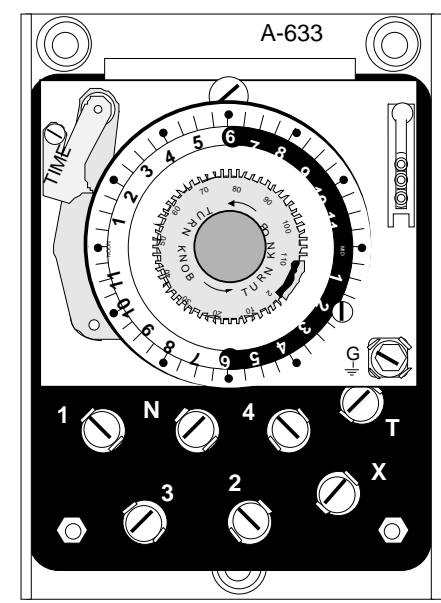
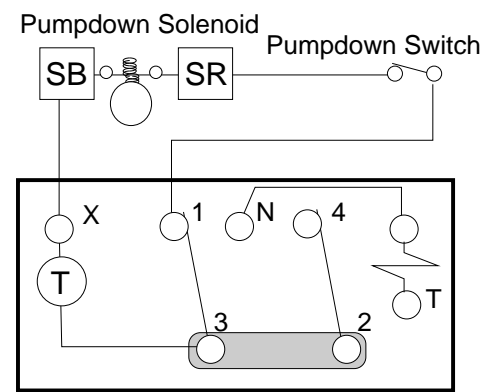

Figure 4-3 A633 Timer

P/N 311859E

4 - 4

**CD104MB Indoor Clock,
for Defrost Duration over 110 minutes.**

APPLICATIONS

Temperature Range- Medium
Types of Defrost- Off-Time
Types of Termination- Time

On call for refrigeration contacts 1 - 2
and 4 - 3 close.

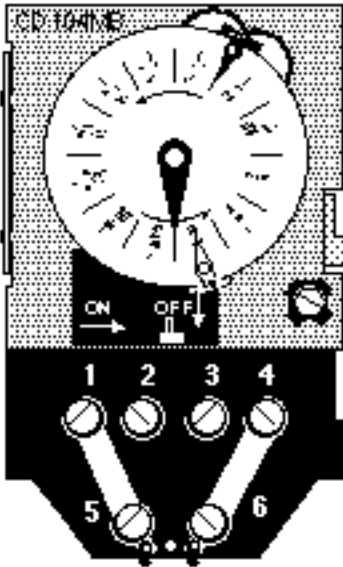
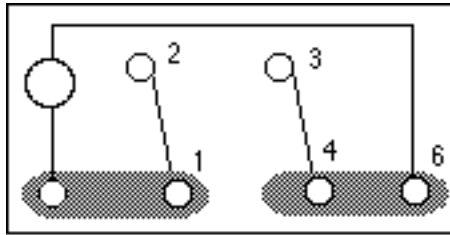

HEAT RECLAIM CIRCUITS

Heat Reclaim Solenoids often have a power supply separate from the HICA, HOCA or HIRU. Heat Reclaim requires a Pumpdown Solenoid which is energized while the compressor is running.

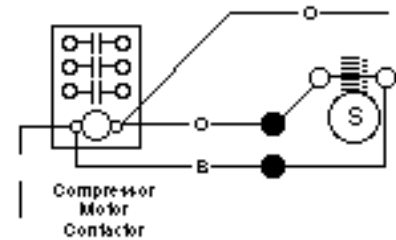
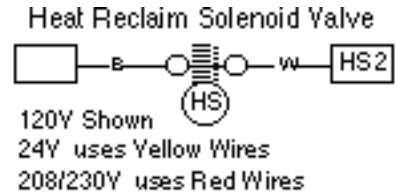

When Reverse Cycle Defrost is used, the HICA will have a lockout relay to keep Heat Reclaim from operating during defrost. The Lockout Relay Coil is energized during defrost, opening the Heat Reclaim Circuit.

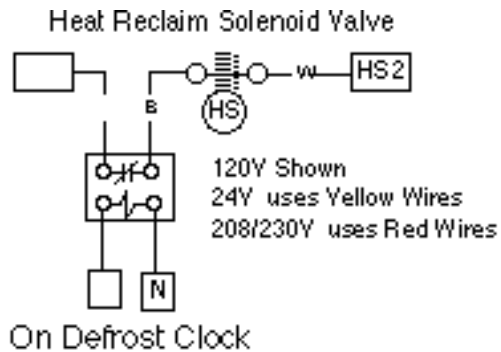

Figure 4-6 Heat Reclaim Circuit with

FAN CYCLING CIRCUITS

Condenser fans come on with the compressor. In addition a pressure type fan cycling control may be used.

A single fan is spliced into the Orange and Brown wires in the compressor terminal box. If a fan cycling control is added, it is placed in series with the fan.

On Fan Banks a fan contactor controls the 3 phase power to the fans. The Fan Contactor Coil is wired parallel to the Compressor Motor Contactor Coil.

Fan Cycling Control is spliced into the Orange wire in the Compressor Terminal Box. If the #1 Fan is cycled with the compressor it is spliced into the Orange and Brown wires in the Compressor Terminal Box. Fans #2 thru #6 remain wired as shown.

With Variable Speed Fan Control, while the compressor is running the fan RPM is reduced as the condenser pressure drops below a set point.

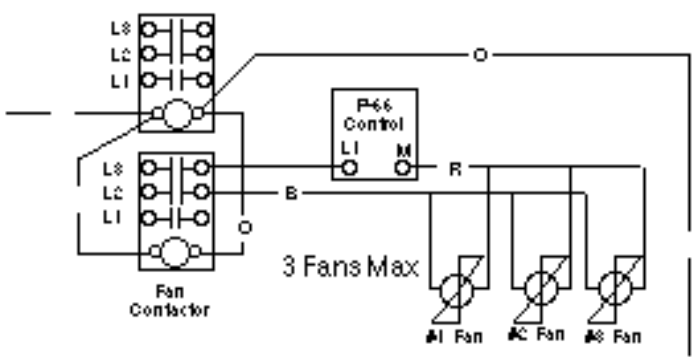
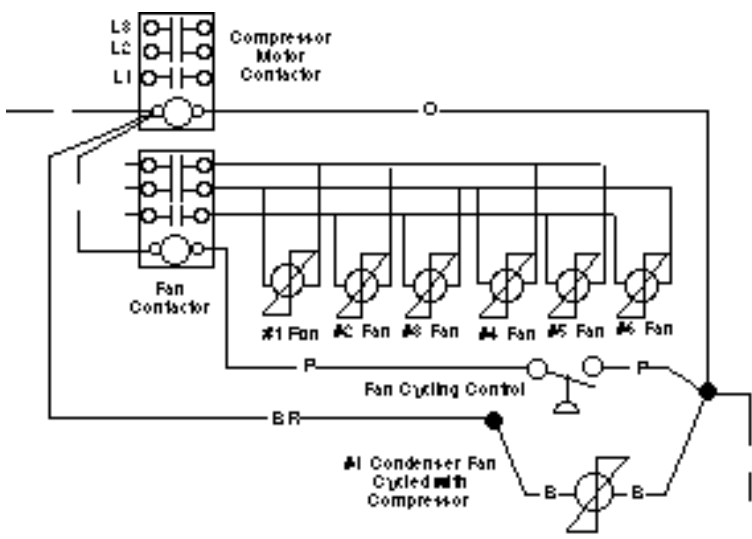
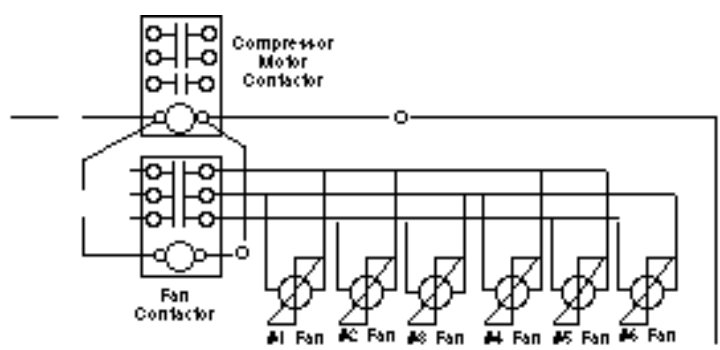
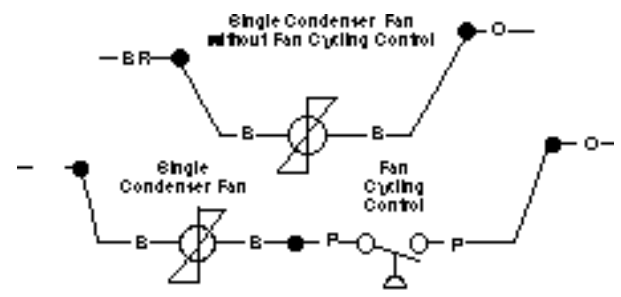

Since Reverse Cycle Defrost uses the ambient heat around the condenser to defrost the merchandiser evaporator, the condenser fans need to be running during defrost. Reverse Cycle Defrost includes a Bypass Relay parallel to the cycling control. This Normally Closed Relay is energized during Refrigeration mode. In Defrost the de-energized relay completes a circuit around the cycling control.

Should the Bypass Relay fail, the fans will cycle with the compressor.

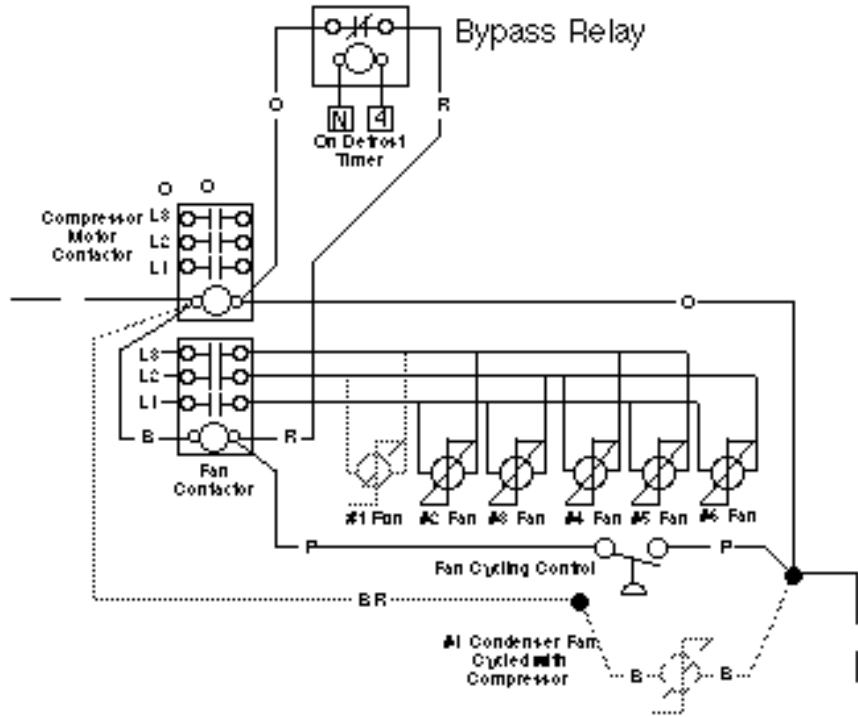

Figure 4-11 Fan Bank Circuits with Reverse Cycle Defrost

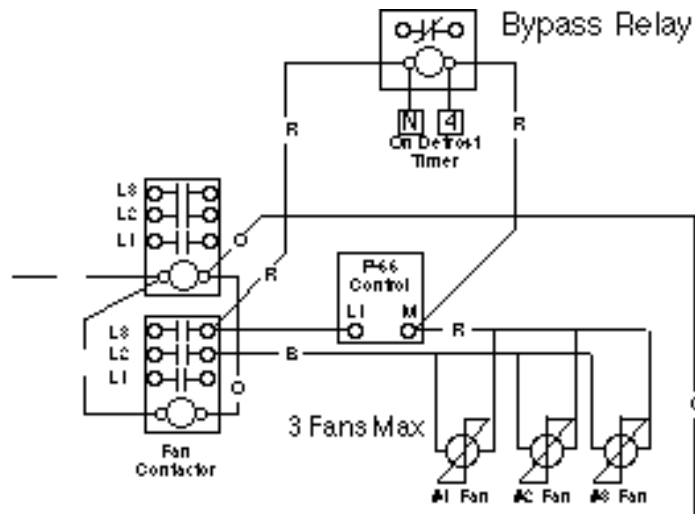
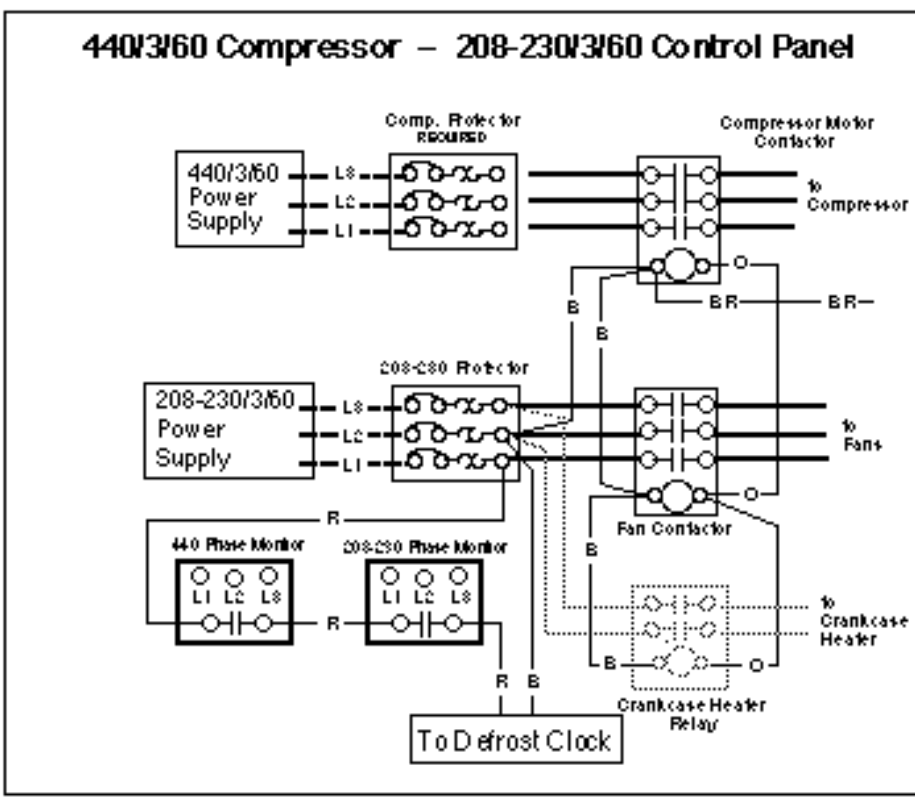

Figure 4-12 Variable Speed Fan Control with

440V COMPRESSORS

When 440V compressors are used a second power supply of 208/230V 3Ph must be wired to the control panel for fans and control circuits.



ELECTRIC DEFROST

Sub Breaker Wiring to the merchandisers must be done to provide good phase balance from the Defrost Contactor. Individual merchandiser amp loads must be taken in to account.

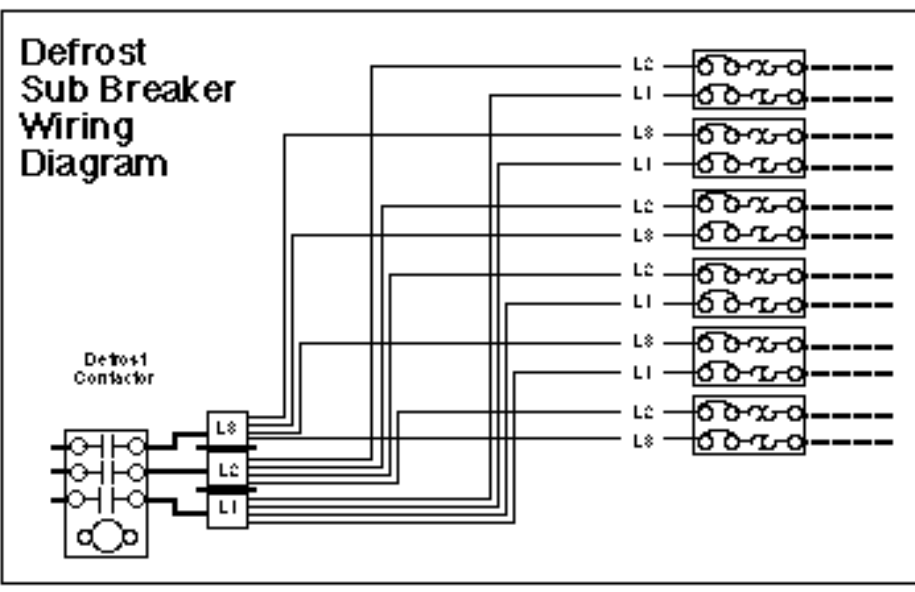

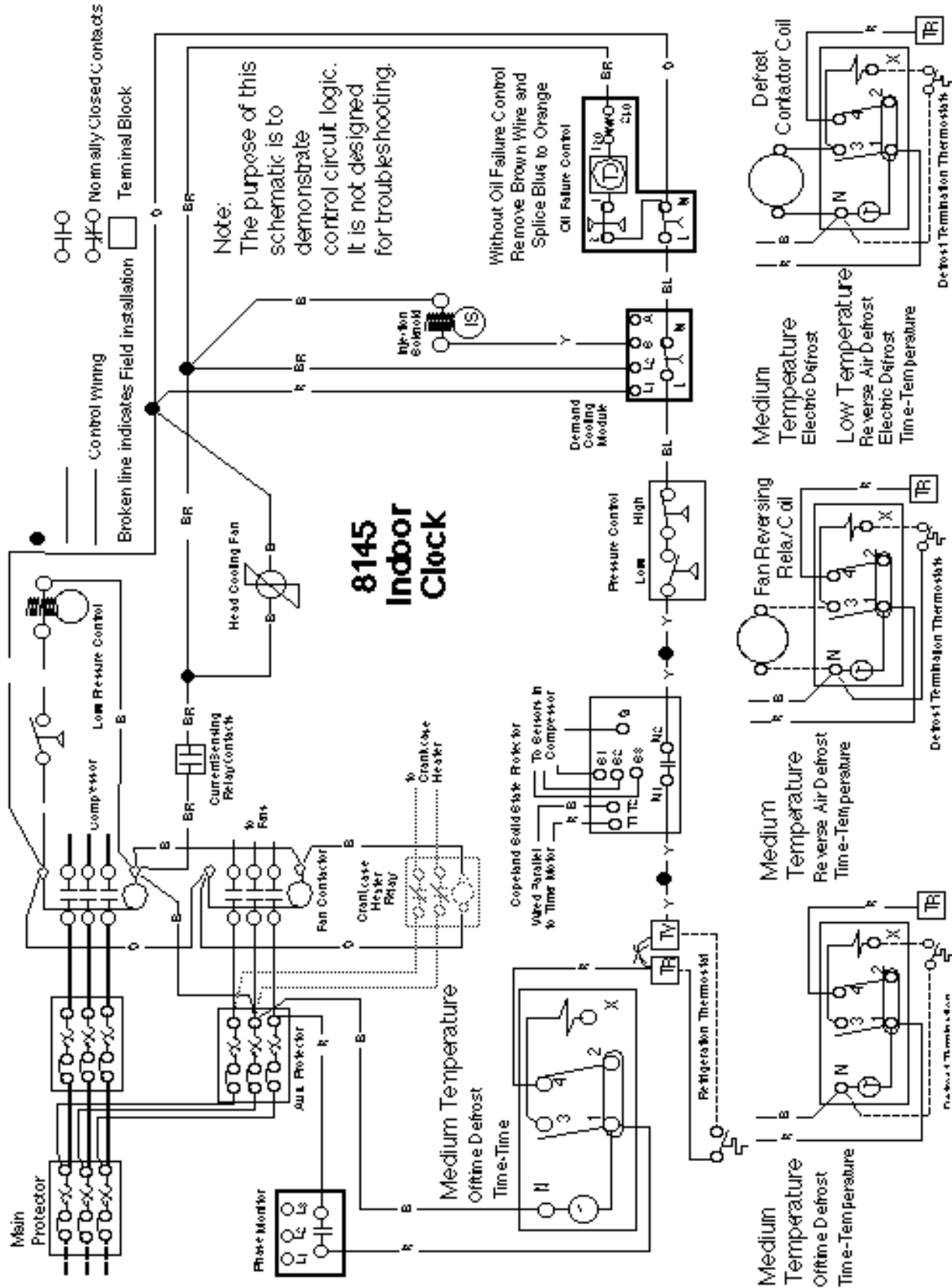

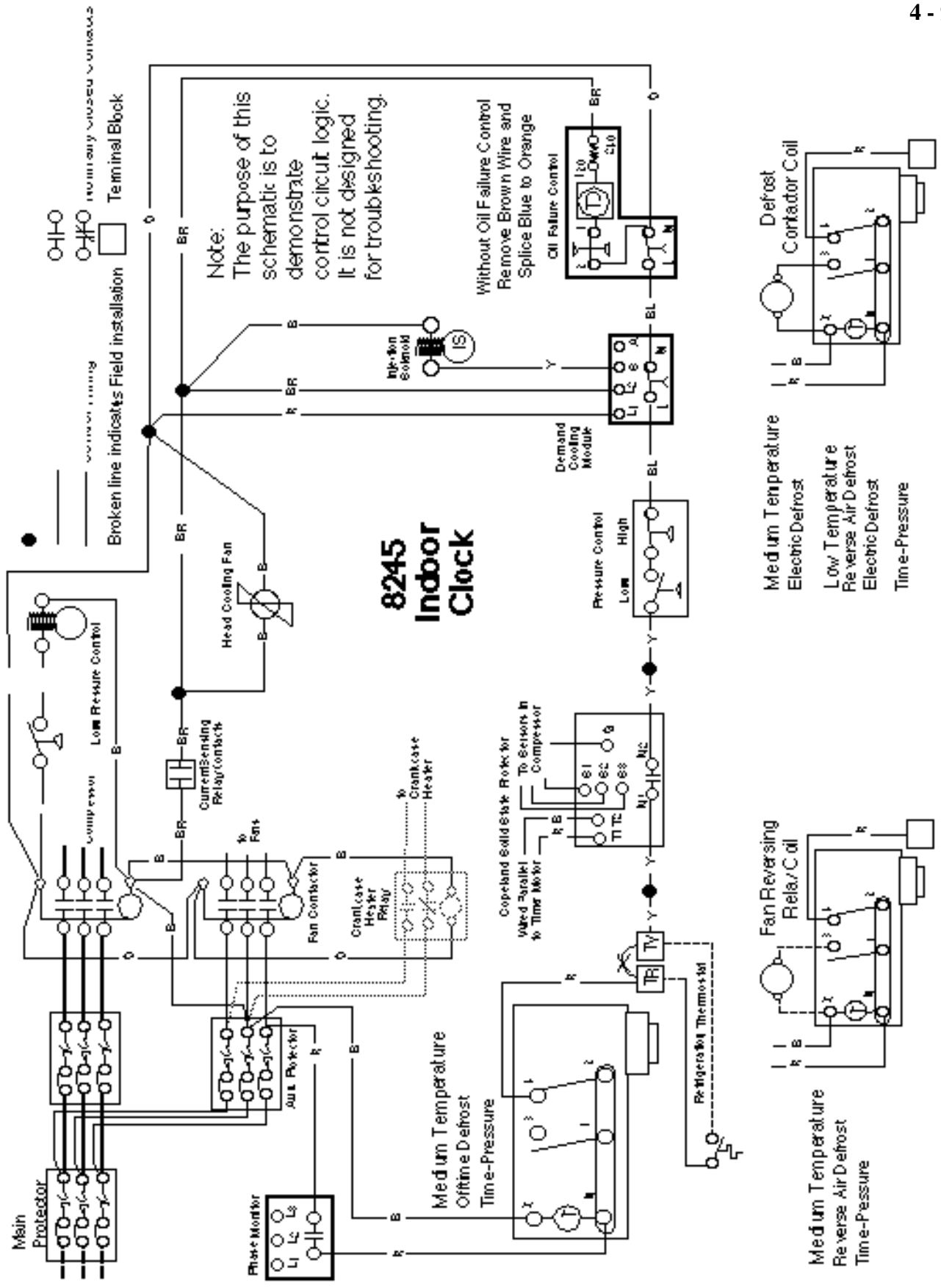

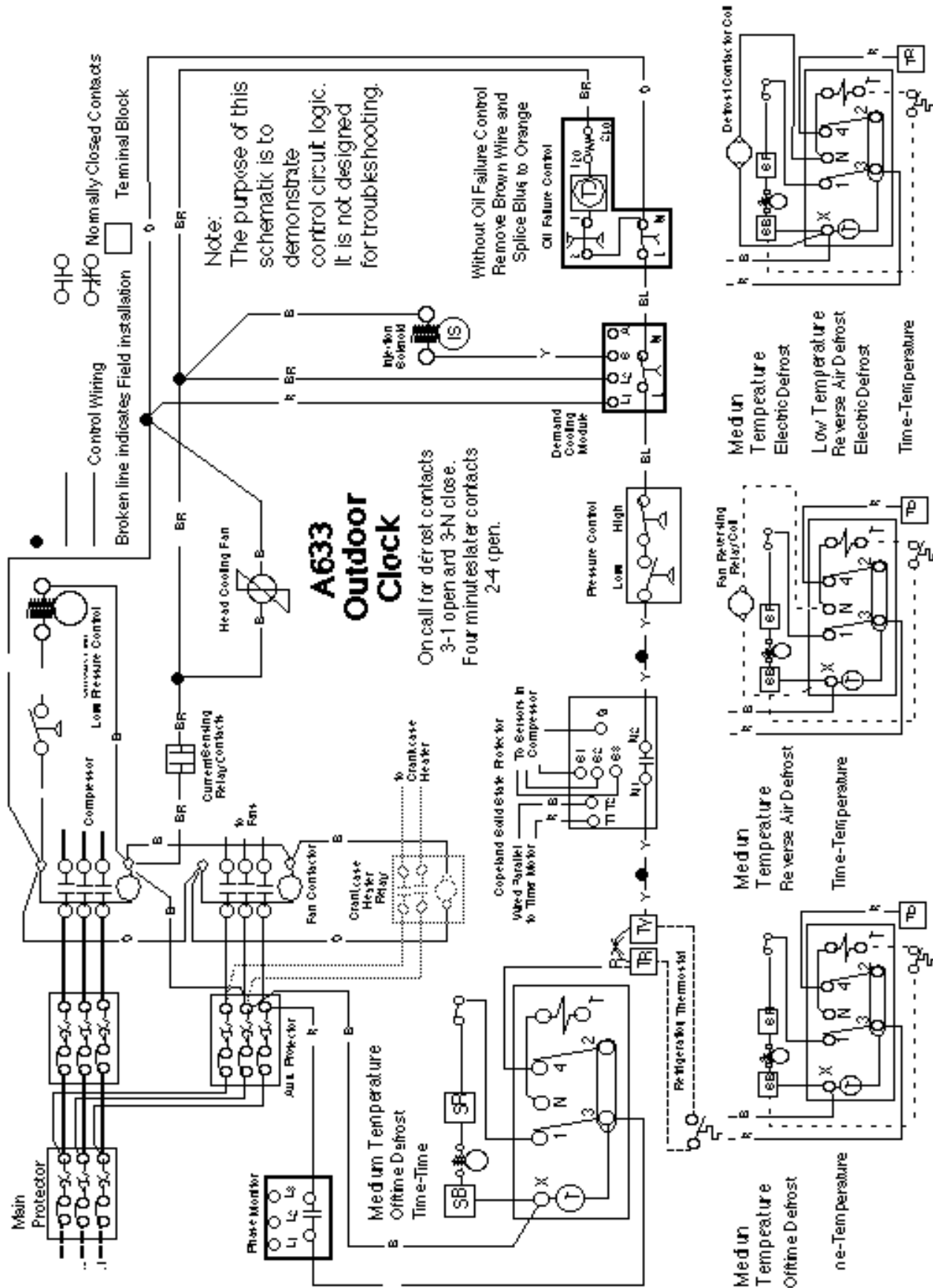

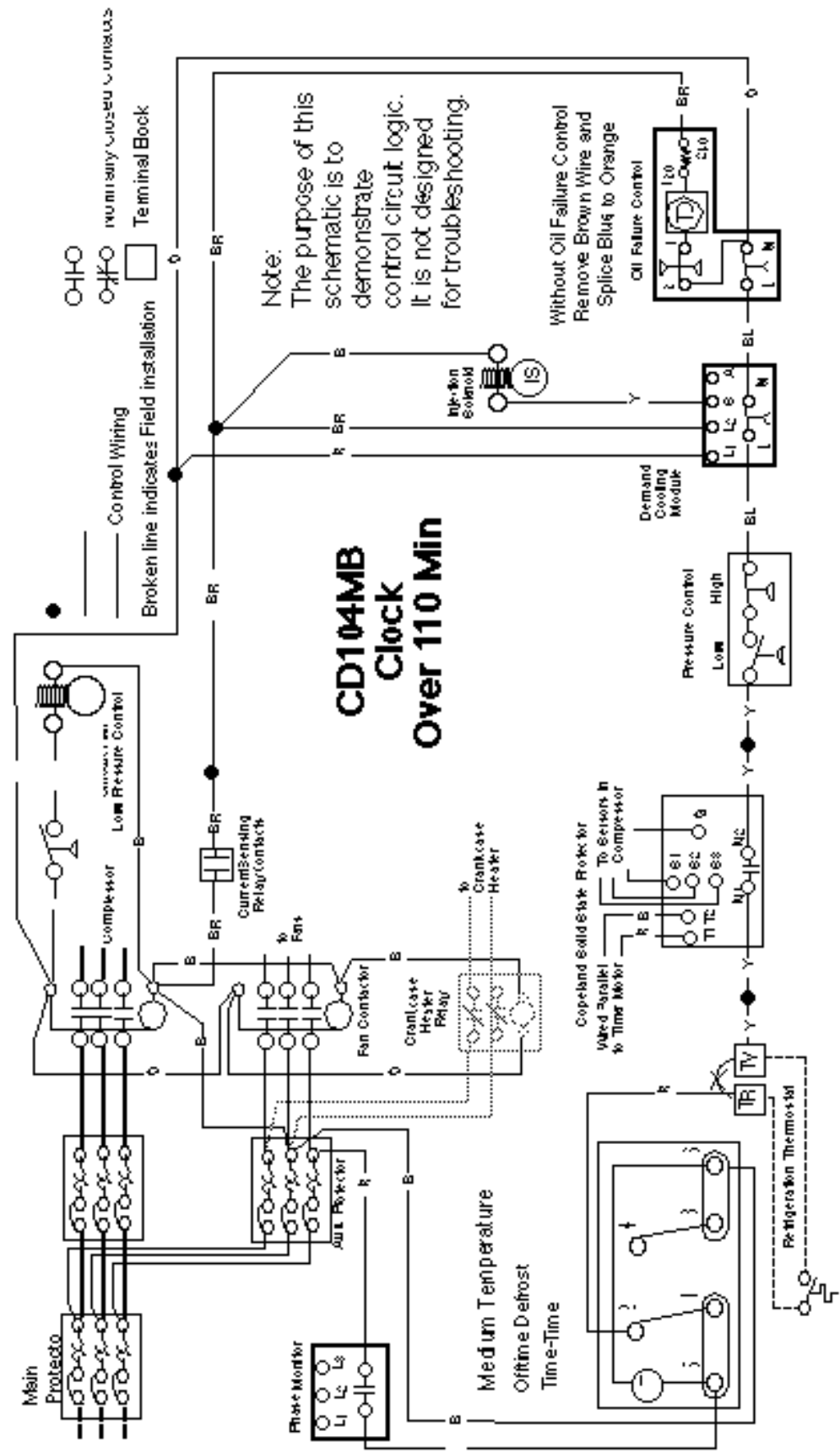

**Special Provisions for
Copeland Scroll Compressors:**

Liquid Injection

Copeland's Midpoint Liquid Injection is standard on all low temperature (ZF) scroll compressor models. A precision sized capillary tube mounted on the compressor is fed from the unit liquid line after the drier. The refrigerant flow to the capillary tube is controlled by a solenoid valve which closes when the compressor is not running. On the 3 – 6 HP models, a current sensing relay is included to close the solenoid if the compressor shuts off on internal protection.

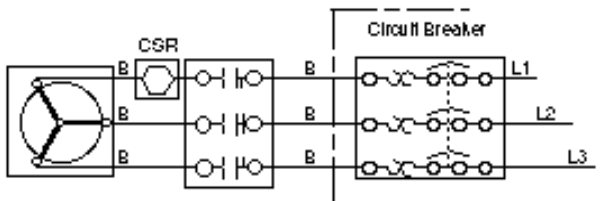

Figure 4-15 Current Sensing Relay Wiring

Discharge Line Thermostat

A discharge line thermostat is standard on all Copeland scroll compressors 6 HP and smaller. The thermostat will prevent discharge line temperature from exceeding 250°F and it is to be located on the discharge line 6 inches from the discharge service valve. Refer to diagram below for wiring detail.

Oil Level Monitoring

The oil level in scroll compressors is monitored by the Sporlan Trax-Oil device. On Conventional Units the Trax-Oil is used as a compressor protective device only. The Trax-Oil has a sight glass with a float to indicate the actual oil level in the compressor. When the oil level drops below ½ sight glass for more than 120 seconds, the Trax-Oil unit will open the compressor control circuit.

Phase Monitor

A phase monitor is standard on the scroll (3-phase) compressor units. It is a requirement that the scroll operate with the correct direction of rotation, so a monitor is needed to ensure correct phase orientation. The phase monitor will open the control circuit if the phases are not aligned properly as well as for low voltage, loss of phase, and voltage unbalance. If the phase sequence is incorrect switch two of the incoming power legs to the unit. As a further check the pumping direction of the compressor should be verified. (See Start-Up, Section 5.)

Note:
Trax-Oil requires a 24V power source at this time.
Future design changes will eliminate this requirement

Both the discharge thermostat and the Trax-Oil have alarm contacts which are not wired as standard on Conventional Units.

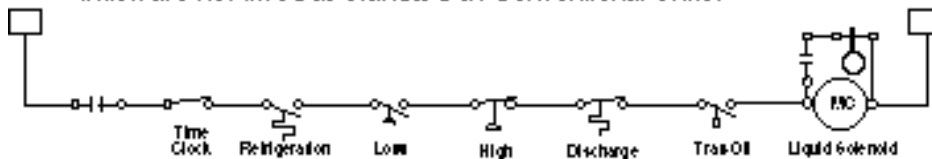

Figure 4-16 Wiring for Discharge Thermostat, Trax-Oil, and Liquid Injection

ADDITIONAL TIMER CIRCUITS WITH REVERSE CYCLE DEFROST

If a Drip Cycle is desired at the end of Defrost, a Time Delay Relay is added. The Relay Coil is wired between "4" and "N" on the defrost timer and has an adjustable delay on circuit make. The normally open contacts are wired from "2" on the timer to "TR." If the relay fails, the system will not refrigerate.

When used, a Fan Cycling Bypass Relay Coil is wired between "4" and "N" on the defrost timer. The normally closed contacts are wired parallel to the fan cycling control. If the relay fails the fans will cycle with the compressor.

A Heat Reclaim Lockout Relay is required with Heat Reclaim. Its Coil is wired between "3" and "N" on the defrost timer. The normally closed contacts are wired in series with the Heat Reclaim Solenoid. If this relay fails Heat Reclaim may remain on during the defrost cycle.

The Reverse Cycle Defrost Solenoid is Wired between "3" and "N" on the defrost timer. Because of system capacity requirements a Ranco valve with a 24V Solenoid is used on larger systems. A 208/230V by 24V Class 2 transformer is wired between "3" and "N" on the defrost timer. The Transformer powers the Valve Solenoid during defrost.

If the Solenoid or Transformer fail the system will be left in refrigeration mode.

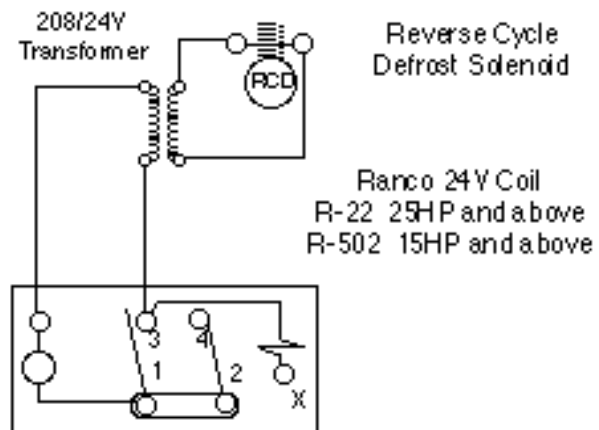
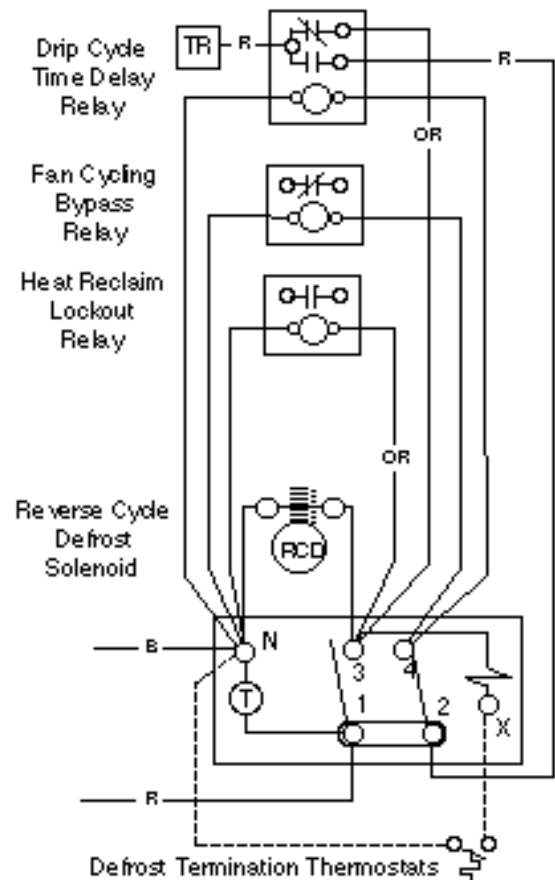

Figure 4-17 Timer Circuits with Reverse Cycle Defrost

HEAT RECLAIM TWO STAGE THERMOSTAT

The thermostat should be located in an area where air discharge grilles create an average air mix of normal store air. This will prevent it from being affected by abnormal air conditions such as heat from appliances and lights; cold air from refrigerated fixtures, doors and windows; and air from heating and cooling air discharge outlets.

The heat reclaim valve solenoid coil requires a 120V power supply. Wire additional heat reclaim valves in parallel. All wiring should be in accordance with NEC and governing electrical codes.

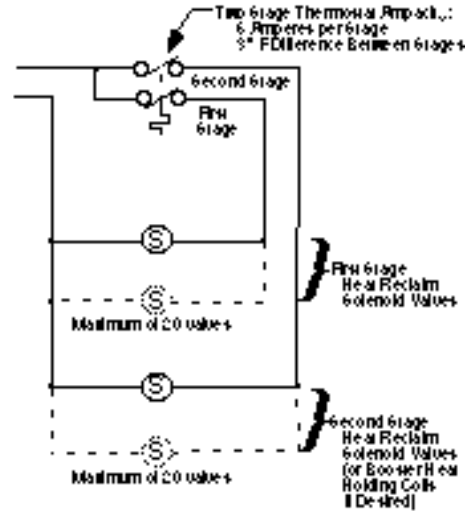

Figure 4-18 Heat Reclaim Schematic5

STARTUP, CONTROL SETTINGS, AND SERVICE

Warning

Know whether a circuit is open at the power supply or not. Remove all power before opening control panels. Note: Some equipment has more than one power supply.

Always use a pressure regulator with a nitrogen tank. Do not exceed 2 pounds of pressure and vent lines when brazing. Do not exceed 350 pounds of pressure for leak testing high side. Do not exceed 150 pounds of pressure for leak testing low side.

Always follow current EPA regulations and guidelines.

STARTUP

Leak Testing

Visually inspect all lines and joints for proper piping practices.

ISOLATE

Compressors—Front-seat Service Valves on Suction and Discharge.

Pressure Transducers—Close Angle Valves.

OPEN

Valves—to condenser, heat reclaim, receiver.

Liquid Line Solenoid Valve—Solenoid should be energized.

DISCONNECT

Defrost Time Clock—Disconnect power to the clock.

VERIFY

Refrigerant requirements for System, Compressors, and TEV's in merchandisers and coolers.

Electrical supply and component requirements.

Test Charge

Use properly regulated dry nitrogen and refrigerant mixture to pressurize the system with vapor only. Bring the system pressure up to 150 psig. Use an electronic leak detector to inspect all connections. If a leak is found, isolate, repair, and retest. Be sure system is at 150 psig and all valves closed to isolate the leak are opened. After the last leak is repaired and retested, the system must stand unaltered for at least 12 hours with no pressure drop from 150 psig.

Warning

Always recapture test charge in approved recovery vessel for recycling.

Oil Levels

Check oil levels for the compressor:

Compressor sight glass $\frac{1}{8}$ to $\frac{1}{2}$ full

If oil level is low, add recommended oil only:

	Copeland	Carlyle
R22	Suniso 3GS	Suniso 3GS
R404A/ R507	Mobile EAL ARCTIC 22 CC	ICI Emkarate RL68H

Evacuation

Nitrogen and moisture will remain in the system unless proper evacuation procedures are followed. Nitrogen left in the system may cause head pressure problems. Moisture causes TEV ice blockage, wax build up, acid oil, and sludge formation.

Do not simply purge the system—this procedure is expensive, harmful to the environment, and may leave moisture and nitrogen behind.

Do not run the compressor to evacuate—this procedure introduces moisture into the compressor's crankcase oil and does not produce adequate vacuum to remove moisture from the rest of the system at normal temperatures.

SETUP

Using all copper lines and packless valves, connect an eight CFM or larger vacuum pump to a 3/8-inch header and from the header to the access port on both the suction and discharge of the Compressor. Connect one micron vacuum gauge at the pump and one at the furthest point in the system from the compressor. Plan procedures so breaking the vacuum with refrigerant will not introduce contaminants into the system. The vacuum pump must be in good condition filled with fresh oil to achieve desired results.

PROCEDURE

Pull a vacuum to 1500 microns. If the vacuum fails to hold, determine the cause and correct. Begin again with the first of the three required evacuations.

Break the vacuum with R22 vapor to a pressure of about 2 psig. Do not exceed the micron gauge transducer's maximum pressure limit. Liquid refrigerant may cause damage to components through thermal shock or a pressure surge to the transducer of the micron gauge.

Repeat first two steps.

Install the suction and liquid drier cores.

Pull a vacuum to 500 microns. Close vacuum header valves and allow system to stand for a minimum of 12 hours. If the 500 micron vacuum holds, charging may begin. If not, the cause must be determined and corrected. Repeated the entire evacuation procedure from the first step.

Warning

Never trap liquid refrigerant between closed valves. A hydraulic explosion may result.

PRE-CHARGE CHECK LIST

While the system is being evacuated preparation for charging can begin. During any of the pull downs check:

Merchandisers

- Electrical requirements and power supply
- Electrical connections tight and clean
- Proper fan operation
- Thermostat setting.

Walk-in coolers and freezers

- Electrical requirements and power supply
- Electrical connections tight and clean
- Proper fan operation
- Thermostat setting.

Condensers

- Electrical requirements and power supply
- Electrical connections tight and clean
- Proper fan operation
- Thermostat or pressure settings
- Damper operation, if equipped.

Heat Reclaim and other systems

- Electrical requirements and power supply
- Electrical connections tight and clean
- Component operation.

Note: Remember to reinstate control to unit components jumpered to make tests.

Set all mechanical pressure controls. Compressors should still be isolated from the rest of the system.

During the last evacuation look up and make a list of the required control settings for the system. A copy of the equipment legend will be needed to determine the system's design operating points. High and low pressure, heat reclaim lockout, winter control settings, and other controls on the system should be noted.

Charging

Use standard procedures for charging while watching for possible problems. Check:

- Suction and discharge pressure
- Oil Level
- Voltage differential and balance
- Ampere draw and balance.

Shut down the unit at first indication of unusual operation, locate and correct cause.

Leak testing, evacuation and initial charging are now completed.

Note: With non-azeotropic refrigerants, it is best to charge the entire contents of the cylinder to prevent fractionalization of the refrigerant when charging vapor.

Winter Charge

When charging HOCA units equipped with winter Head Pressure Control (HPC) Valving, additional refrigerant is required for winter operation. The additional quantity by weight which should be added is determined by Nominal Condenser Size and ambient temperature entering the condenser during charging procedure.

Winter Charge (pounds) for HOCA Units with HPC Valving					
NOMINAL CONDENSER SIZE	AMBIENT TEMPERATURE ENTERING CONDENSER				
	>80°F	60°F	40°F	20°F	0°F
0.5 to 1.0	5	4	2	1	0
1.5	6	6	3	1	0
2	10	7	4	2	0
3	20	15	10	5	0
4 to 6	35	25	16	8	0
7.5 to 10	50	37	24	12	0
10 to 12	70	50	32	16	0
15 to 20	100	74	48	24	0
22 to 30	120	94	56	34	0

Compressor Motor Rotation

To check compressor rotation, use the following procedure:

1. Install gauges on suction and discharge side of compressor. A momentary compressor run should cause a drop in suction header and a rise in discharge header pressure.
2. With main disconnect **OFF**, switch **OFF** all breakers in the control panel.
3. Turn **ON** main disconnect.
4. Look for the light on the single phase protector. If it is not lit, turn **OFF** the main disconnect. Have the field connections to the main breaker of the unit corrected so the phase protector indicates phase alignment. (The light is lit.)
5. Turn **ON** main disconnect.
6. Momentarily turn **ON** the compressor breaker and verify correct pumping direction. If the compressor is rotating backwards, change two Legs on the load side of the compressor contactor.

Note: DO NOT run compressors for more than 10 seconds during test.

Final Checks

Once the system is up and running, it is the responsibility of the installer to see that all the fine adjustments are made so the Custom Conventional delivers maximum temperature performance and efficiency for the customer. These include:

- Defrost scheduling and timing
- Condenser controls
- Winter controls
- EPR settings
- TEV superheat adjustment
- CPR settings
- High and low pressure controls
- Thermostat settings
- Adjustments to electronic controls.

Thoroughly inspect all field piping while the equipment is running and add supports where line vibration occurs. Be sure additional supports do not conflict with pipe expansion and contraction.

When merchandisers are completely stocked, check the operation of the system again.

At 48 hours of operation, replace the liquid drier and suction filter cores.

At 90 days recheck the entire system, including all field wiring.

CONTROL SETTINGS

Compressor Oil Failure Safety requires manual reset.

Compressor	Cut-in (psig)	Cut-out (psig)	Time Delay (seconds)
Copeland	7-11	12-18	90-150
Carlyle	4-6	9-12	45-75

High Pressure Safety

High pressure safety for both R22 and R404a is 395 psig cut-out. Differential is fixed.

R134a safety is set at 240 psig cut-out.

Low Ambient Controls

The customer may specify lower pressure settings than those recommended; however, refrigeration performance may be affected. Minimum receiver pressure is 140 psig.

Refrigerant	Flooding Valve (Liquid) (psig)	Receiver Pressure (Vapor) (psig)
R404a	205	185
R22	175	155

EPR Settings

Evap Temp (°F)	EPR Pressure Refrigerant R404a	Setting (psig) Application R22
-25	13	7
-22	15	9
-20	16	10
-15	20	14
6	39	29
9	43	32
12	46	35
15	49	38
18	53	41
21	57	44
25	62	49
30	70	55

NOTE: The final test for proper EPR setting must be discharge air temperature.

Condenser Fan Cycling

Refrigerant	Setting (psig)
R404a	220
R22	185
R134a	115

LOW PRESSURE CONTROL

R22 Low Temp		
Design Suction Temp °F	Compressor	
	CI psig	CO psig
-33	4	0
-30	5	1
-28	6	2
-25	7	3
-23	8	4
-21	9	5
-20	10	6
-16	12	7
-15	13	9
-10	17	13

R22 Med Temp		
Design Suction Temp °F	Compressor	
	CI psig	CO psig
7	26	20
10	29	23
12	31	25
14	33	27
15	34	28
16	35	29
20	39	33
23	42	36
25	45	39
30	51	45
35	57	51
40	64	58
45	72	66

R134a Med Temp		
Design Suction Temp °F	Compressor	
	CI psig	CO psig
7	10	6
10	12	8
12	13	9
14	14	10
15	15	11
16	16	12
20	18	14
23	21	17
25	22	18
30	26	22
35	30	26
40	35	31

R404a Low Temp		
Design Suction Temp °F	Compressor	
	CI psig	CO psig
-33	8	4
-30	10	6
-28	11	7
-25	13	9
-23	14	10
-21	16	12
-20	17	13
-16	19	15
-15	20	16
-10	24	20

R404a Med Temp		
Design Suction Temp °F	Compressor	
	CI psig	CO psig
7	40	36
10	44	40
12	46	42
14	48	44
15	49	45
16	50	46
20	56	52
23	60	56
25	62	58

Caution:

Never run the compressors in a vacuum.

SERVICE

This Procedure is not designed to cover system changeover to a different refrigerant.

Compressor Replacement

Since each machine room tends to be unique, plan carefully as to how you will move the compressors without harming personnel, equipment or the building. Before beginning removal of old compressor make replacement unit ready to install:

VERIFY

Replacement compressor

Electrical requirements

Refrigerant application

Capacity

Piping hookup location and design

Suction and discharge gaskets

Mounting requirements.

Have compressor in an easily accessible position, uncrated and unbolted from shipping pallet.

DISCONNECT ELECTRICAL SUPPLY

Turn off motor and control panel power supplies to the Unit.

Turn off control circuit and open all compressor circuit breakers.

Tag and remove electrical wires and conduit from the compressor.

ISOLATE COMPRESSOR

Front-seat Suction and Discharge Service Valves.

Bleed compressor pressure through both discharge and suction access ports into an **approved recovery vessel**.

Remove externally mounted components which will be re-used on the replacement compressor.

Plug holes to compressor manufacturer's specifications.

Disconnect suction and discharge service valves.

Remove mounting bolts.

When moving the compressor, use a come-along, hoist or hydraulic lift to carry the weight.

Do not use the piping or panel to support a hoist or come-along.

Do not use ceiling trusses to support a hoist or come-along.

A properly constructed ceiling rail may be used to support a hoist or come-along.

On semi-hermetic compressors, an eye bolt may be installed in the rear top of the compressor head to make hookup and lifting easier.

When the old compressor has been removed, clean the suction and discharge service valve gasket surfaces to shiny metal. Clean the gasket surfaces on the new compressor to shiny metal. Be careful not to groove or round the surfaces. Gasket surfaces must be clean to prevent leaking.

Install the new compressor in reverse order of removal. Be sure compressor is charged with proper oil for the application. If the compressor is less oil, charge it with the proper oil for the application. Do not open the new compressor to the system until after it has been leak tested and triple evacuated.

Replacing Drier and Filter Cores

Shut down the system. Isolate the core to be replaced and bleed off pressure into an **approved recovery vessel**. Open housing, replace core and close up. Pressurize, leak test and bring back into line.

HUSSMANN®

Limited Warranty

This warranty is made to the original user at the original installation site and is not transferable.

Hussmann merchandisers are warranted to be free from defect in material and workmanship under normal use and service for a period of one (1) year from the date of original installation (not to exceed fifteen (15) months from the date of shipment from the factory). **Hussmann Impact Modular Coils are warranted for a total of five (5) years based upon the above criteria.** Hussmann's obligation under this warranty shall be limited to repairing or exchanging any part or parts, without charge F.O.B. factory or nearest authorized parts depot within said period and which is proven to the satisfaction of the original manufacturing plant warranty group to be thus defective.

Hussmann covers the entire case or refrigeration product and all its components (except for lamps, driers, fuses, and other maintenance type replacement parts) for the one (1) year warranty period.

Additionally, Hussmann warrants for a total period of three (3) years all sealed, multi-glass assemblies except those used in sliding doors on closed meat display cases. If within three (3) years from the date of installation (not to exceed thirty-nine (39) months from the date of shipment from factory), it shall be proven to the satisfaction of the originating factory warranty group that there is impaired visibility through the multi-glass assemblies thereof caused by moisture between the glasses, the multi-glass assembly will be replaced free of charge, F.O.B. factory. This additional warranty excludes accident, misuse, or glass breakage.

On Hussmann-Gloversville manufactured self-contained display cases, Hussmann agrees to repair or exchange, at its option, the original motor/compressor unit only with a motor/compressor of like or of similar design and capacity if it is shown to the satisfaction of Hussmann that the motor/compressor is inoperative due to defects in factory workmanship or material under normal use and service as outlined in Hussmann's "Installation Instructions" which are shipped inside new Hussmann equipment. Hussmann's sole obligation under this warranty shall be limited to a period not to exceed five years from date of factory shipment.

On Hussmann refrigeration systems (Atlanta, Bridgeton, Brantford, Chino) and self-contained display cases (Bridgeton, Brantford, Chino, Denver), an additional (4) year extended warranty for the motor/compressor assembly is available, but must be purchased prior to shipment to be in effect. Hussmann reserves the right to inspect the job site, installation and reason for failure.

The motor/compressor warranties listed above do not include replacement or repair of controls, relays, capacitors, overload protectors, valve plates, oil pumps, gaskets or any external part on the motor/compressor replaceable in the field, or any other part of the refrigeration system or self-contained display case.

THE WARRANTIES TO REPAIR OR REPLACE ABOVE RECITED ARE THE ONLY WARRANTIES, EXPRESS, IMPLIED OR STATUTORY, MADE BY HUSSMANN WITH RESPECT TO THE ABOVE MENTIONED EQUIPMENT, INCLUDING ANY IMPLIED WARRANTY OF MERCHANTABILITY OR FITNESS, AND HUSSMANN NEITHER ASSUMES NOR AUTHORIZES ANY PERSON TO ASSUME FOR IT, ANY OTHER OBLIGATION OR LIABILITY IN CONNECTION WITH THE SALE OF SAID EQUIPMENT OR ANY PART THEREOF.

THIS WARRANTY SHALL NOT APPLY TO LOSS OF FOOD OR CONTENTS OF THE EQUIPMENT DUE TO FAILURE FOR ANY REASON. HUSSMANN SHALL NOT BE LIABLE:

- For payment of labor for any removal or installation of warranted parts;
- For any repair or replacements made without the written consent of Hussmann, or when the equipment is installed or operated in a manner contrary to the printed instructions covering installation and service which accompanied such equipment;
- For any damages, delays, or losses, direct or consequential which may arise in connection with such equipment or part thereof;
- For damages caused by fire, flood, strikes, acts of God or circumstances beyond its control;
- When the equipment is subject to negligence, abuse, misuse or when the serial number of the equipment has been removed, defaced, or altered;
- When the equipment is operated on low or improper voltages
- When the equipment is put to a use other than normally recommended by Hussmann (i.e. deli case used for fresh meat);
- When operation of this equipment is impaired due to improper drain installation;
- For payment of refrigerant loss for any reason;
- For costs related to shipping or handling of replacement parts.

Hussmann Corporation, Corporate Headquarters: Bridgeton, Missouri, U.S.A. 63044-2483

August 15, 1998