

Fluid Cooler Series

Air-Cooled Fluid Cooling Units

Operating and Installation Manual

TABLE OF CONTENTS

1	RECEIPT OF EQUIPMENT	3
1.1	INSPECTION	3
1.2	LOSS OF GAS HOLDING CHARGE	3
2	MODELS AND DIMENSIONS	3
2.1	UNIT MODELS	3
2.2	30" UNIT DIMENSIONS AND MOTOR AMPS	4
2.3	30" UNIT MOTOR AMPS	5
2.4	30" UNIT WEIGHTS AND REFRIGERANT CHARGES	6
2.5	24" UNIT DIMENSIONS AND MOTOR AMPS	7
3	UNIT LOCATION	8
4	RIGGING	9
5	UNIT ASSEMBLY	11
5.1	LEG ASSEMBLY FOR 30" FAN UNITS	11
5.2	HORIZONTAL AIRFLOW UNIT	11
5.3	LEG ASSEMBLY FOR 24" FAN UNITS	12
6	INSTALLATION AND PIPING	13
6.1	MOUNTING THE UNIT	13
6.2	INTERCONNECTING PIPING FOR DOUBLE WIDE UNITS	13
6.3	FLUID PIPING	13
7	ELECTRICAL	15
7.1	FIELD WIRING	15
7.2	MOTORS WIRED TO TERMINAL BLOCKS	15
7.3	MOTORS WIRED TO STANDARD FAN CYCLING CONTROL PANEL	16
7.4	FAN CYCLE OPERATION	17
7.5	CONTROL SETTINGS	18
7.6	TEMPERATURE SENSOR	18
8	INSPECTION AND CLEANING	20
9	REPLACEMENT PARTS LIST	21

TABLES

Table 1	30" UNIT DIMENSIONS	4
Table 2	30" UNIT TOTAL MOTOR AMPS	5
Table 3	30" UNIT WEIGHTS AND INTERNAL VOLUMES	6
Table 4	24" UNIT DIMENSIONS, AMPS, INTERNAL VOLUMES AND WEIGHTS	7
Table 5	CONTROL PANEL SETTINGS	19
Table 6	REPLACEMENT PART NUMBERS	21

FIGURES

Figure 1	30" UNIT DIMENSIONS	4
Figure 2	24" UNIT DIMENSIONS	7
Figure 3	LOCATION REQUIREMENTS.....	8
Figure 4	RIGGING AND LIFTING FOR 30" FAN UNITS.....	9
Figure 5	RIGGING AND LIFTING FOR 24" FAN UNITS.....	10
Figure 6	STANDARD 22" & 42" LEG ASSEMBLY.....	11
Figure 7	STANDARD 42" LEG & BRACING ASSEMBLY.....	12
Figure 8	UNIT MOUNTING AND PIPING	14
Figure 9	TYPICAL PIPING	15
Figure 10	TERMINAL BLOCK ONLY WIRING DIAGRAMS.....	16
Figure 11	FAN CYCLING WIRING DIAGRAMS (-311)	16
Figure 12	FAN CYCLING IN PAIRS WIRING DIAGRAMS (-331).....	17
Figure 13	CONTROL PANEL WIRING DIAGRAMS	17

1 RECEIPT OF EQUIPMENT

1.1 Inspection

All equipment should be carefully checked for damage or shortages as soon as it is received. Each shipment should be carefully checked against the bill of lading. If any damage or shortage is evident, a notation must be made on the delivery receipt before it is signed and a claim should then be filed against the freight carrier. **Inspection and claims are the responsibility of the recipient.**

1.2 Loss Of Gas Holding Charge

The fluid coil section of each Fluid Cooler unit with ODS connections are leak tested, evacuated to remove moisture and then shipped with a pressurized nitrogen gas holding charge. Absence of this charge may indicate a leak has developed in transit. The system should not be filled with fluid until it is verified that there is no leak, or the source of the leak is located and repaired if necessary. If the coil section has MPT or Flanged connections, the coil is not charged. Once the unit is installed in the system check the coil during the system pressure test.

2 MODELS AND DIMENSIONS

2.1 Unit Models

Units with 24" diameter fans are designated "FA...", while the units with 30" diameter fans are "FE...". All units are designed for vertical air discharge, with horizontal air discharge as an option. Each unit is constructed for the fluid and internal working pressure that is indicated on the unit nameplate.

All units contain the UL, cUL, and CSA labels to indicate the unit was manufactured using acceptable practices by the governing bodies.

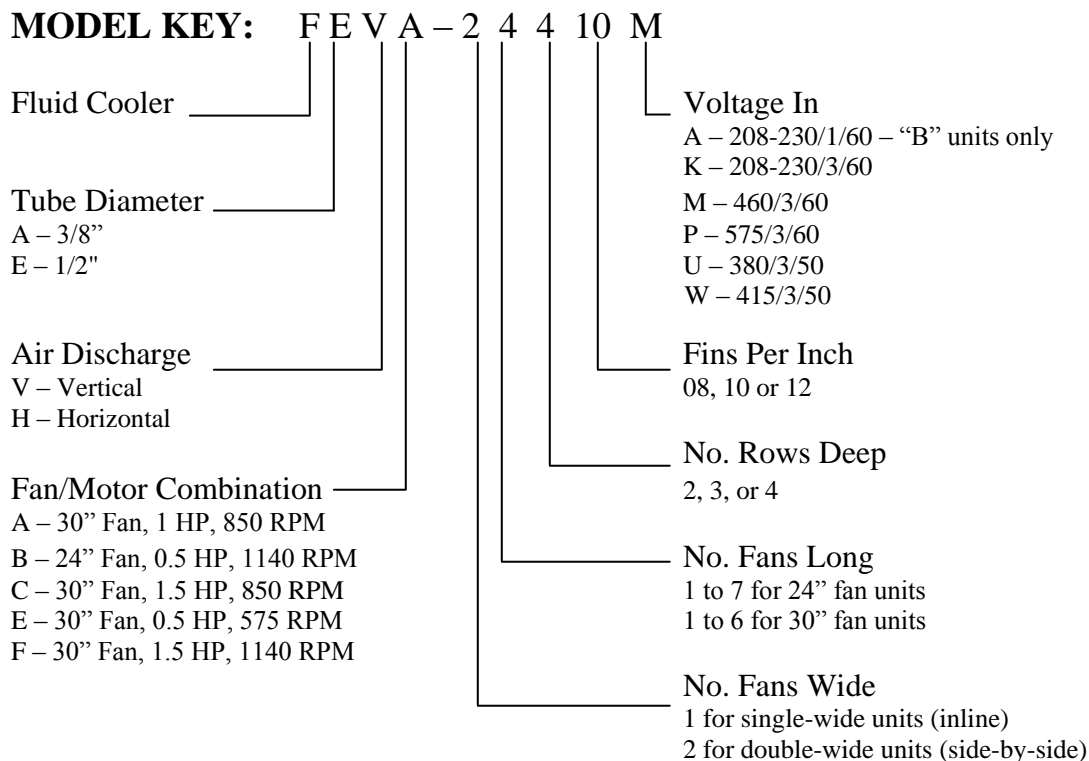

2.2 30" Unit Dimensions And Motor Amps

Figure 1 and Table 1 contain the overall dimensions & support leg bolt hole locations for all of the 30" diameter fan units.

FIGURE 1 30" UNIT DIMENSIONS

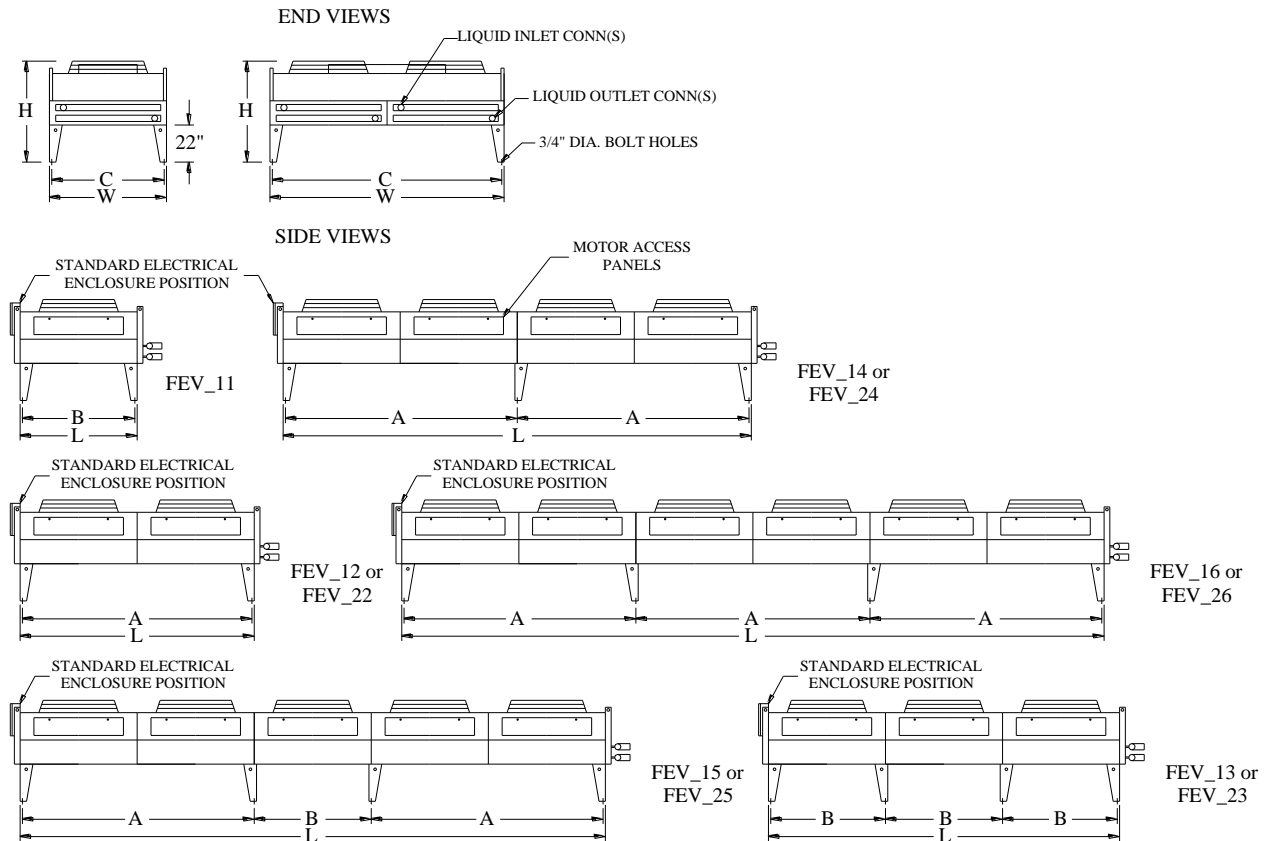

Table 1 30" UNIT DIMENSIONS

SINGLE WIDE DIMENSIONS (inches)							CONN OD (IN)	
MODEL	L	W	H**	A	B	C	INLET	OUTLET
FEV_11***	58	45.25	54	-	54	41.25	*	*
FEV_12***	112	45.25	54	108	-	41.25	*	*
FEV_13***	166	45.25	54	108	-	41.25	*	*
FEV_14***	220	45.25	54	108	-	41.25	*	*
FEV_15***	274	45.25	58.5	108	54	41.25	*	*
FEV_16***	328	45.25	58.5	108	-	41.25	*	*

DOUBLE WIDE DIMENSIONS (inches)							CONN OD (IN)	
MODEL	L	W	H**	A	B	C	INLET	OUTLET
-	-	-	-	-	-	-	-	-
FEV_22***	112	90.5	54	108	-	86.5	*	*
FEV_23***	166	90.5	54	108	54	86.5	*	*
FEV_24***	220	90.5	54	108	-	86.5	*	*
FEV_25***	274	90.5	58.5	108	54	86.5	*	*
FEV_26***	328	90.5	58.5	108	-	86.5	*	*

* - Connection size is determined by fluid flow rate when unit ordered.

** - Includes standard 22" legs. Increase height accordingly if 30", 36", 42", 48", or 60" extended legs are used. If the 48" or 60" extended legs are used, every fan section down the length of the unit has a leg and cross bracing is required.

*** - Rows & FPI

2.3 30" Unit Motor Amps

The following table contains the motor loads for the different fan horsepower and speeds.

Table 2 30" UNIT TOTAL MOTOR AMPS

ONE FAN WIDE 1 HP 850 RPM				TWO FANS WIDE 1 HP 850 RPM			
MODEL	208/3/60	460/3/60	575/3/60	MODEL	208/3/60	460/3/60	575/3/60
FEVA11***	4.4	2.0	1.5	-	-	-	-
FEVA12***	8.8	4.0	3.0	FEVA22***	17.6	8.0	6.0
FEVA13***	13.2	6.0	4.5	FEVA23***	26.4	12.0	9.0
FEVA14***	17.6	8.0	6.0	FEVA24***	35.2	16.0	12.0
FEVA15***	22.0	10.0	7.5	FEVA25***	44.0	20.0	15.0
FEVA16***	26.4	12.0	9.0	FEVA26***	52.8	24.0	18.0

ONE FAN WIDE 1.5 HP 850 RPM				TWO FANS WIDE 1.5 HP 850 RPM			
MODEL	208/3/60	460/3/60	575/3/60	MODEL	208/3/60	460/3/60	575/3/60
FEVC11***	6.0	3.0	2.5	-	-	-	-
FEVC12***	12.0	6.0	5.0	FEVC22***	24.0	12.0	10.0
FEVC13***	18.0	9.0	7.5	FEVC23***	36.0	18.0	15.0
FEVC14***	24.0	12.0	10.0	FEVC24***	48.0	24.0	20.0
FEVC15***	30.0	15.0	12.5	FEVC25***	60.0	30.0	25.0
FEVC16***	36.0	18.0	15.0	FEVC26***	72.0	36.0	30.0

ONE FAN WIDE 1/2 HP 575 RPM				TWO FANS WIDE 1/2 HP 575 RPM			
MODEL	208/3/60	460/3/60	575/3/60	MODEL	208/3/60	460/3/60	575/3/60
FEVE11***	3.4	1.7	1.2	-	-	-	-
FEVE12***	6.8	3.4	2.4	FEVE22***	13.6	6.8	4.8
FEVE13***	10.2	5.1	3.6	FEVE23***	20.4	10.2	7.2
FEVE14***	13.6	6.8	4.8	FEVE24***	27.2	13.6	9.6
FEVE15***	17.0	8.5	6.0	FEVE25***	34.0	17.0	12.0
FEVE16***	20.4	10.2	7.2	FEVE26***	40.8	20.4	14.4

ONE FAN WIDE 1.5 HP 1140 RPM				TWO FANS WIDE 1.5 HP 1140 RPM			
MODEL	230/3/60	460/3/60	575/3/60	MODEL	230/3/60	460/3/60	575/3/60
FEVF11***	7.0	3.5	2.4	-	-	-	-
FEVF12***	14.0	7.0	4.8	FEVF22***	28.0	14.0	9.6
FEVF13***	21.0	10.5	7.2	FEVF23***	42.0	21.0	14.4
FEVF14***	28.0	14.0	9.6	FEVF24***	56.0	28.0	19.2
FEVF15***	35.0	17.5	12.0	FEVF25***	70.0	35.0	24.0
FEVF16***	42.0	21.0	14.4	FEVF26***	84.0	42.0	28.8

*** - Model number shown does not include rows or fins per inch.

For unit Minimum Unit Circuit Amps (MCA) and Maximum Unit Overload (MOP) consult the factory wiring diagram supplied with the unit.

2.4 30" Unit Weights And Refrigerant Charges

The following table contains approximate unit shipping weights and internal volumes for the 30" fan units.

TABLE 3 30" UNIT WEIGHTS AND INTERNAL VOLUMES

UNIT	APPROX. SHIPPING WT. (LBS)	INTERNAL VOLUME (GAL)
ONE FAN WIDE UNITS		
FEV_112**	445	3.7
FEV_113**	480	5.3
FEV_114**	510	6.9
FEV_122**	730	6.6
FEV_123**	790	9.7
FEV_124**	860	16.6
FEV_132**	1060	9.6
FEV_133**	1150	14.1
FEV_134**	1250	18.7
FEV_143**	1475	18.6
FEV_144**	1600	24.6
FEV_153**	2070	22.9
FEV_154**	2220	30.5
FEV_163**	2610	27.4
FEV_164**	2860	36.4
TWO FAN WIDE UNITS		
FEV_222**	1340	12.8
FEV_223**	1460	19.1
FEV_224**	1590	25.3
FEV_232**	1910	18.7
FEV_233**	2100	27.9
FEV_234**	2290	37.1
FEV_243**	2700	36.7
FEV_244**	2950	48.8
FEV_253**	3820	45.6
FEV_254**	4130	60.7
FEV_263**	4870	54.6
FEV_264**	5370	72.5

** - Fins per inch
 - Motors A, B, C, E, or F

2.5 24" Unit Dimensions And Motor Amps

Figure 2 and Table 4 contain the overall dimensions, leg bolt hole locations, motor amp draws, internal volumes, and weights for all of the units with 24" diameter fans.

FIGURE 2 24" UNIT DIMENSIONS

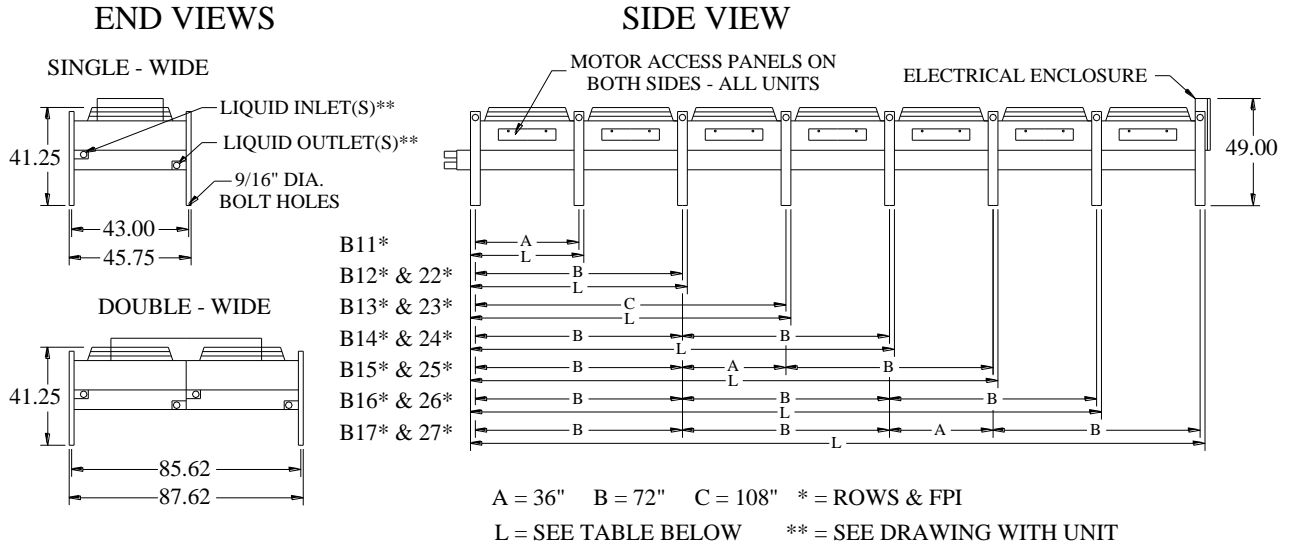

Table 4 24" UNIT DIMENSIONS, AMPS, INTERNAL VOLUMES AND WEIGHTS

UNIT	DIM. L	TOTAL MOTOR FULL LOAD AMPS **						INTERNAL VOLUME (GAL)	APPROX. SHIPPING WEIGHT (LBS)
		208-1	230-1	208-3	230-3	460-3	575-3		
ONE FAN WIDE UNITS									
FAVB11*	39	4.2	4.2	2.8	2.6	1.3	0.76	2.5	180
FAVB12*	75	8.4	8.4	5.6	5.2	2.6	1.52	4.4	360
FAVB13*	111	12.6	12.6	8.4	7.8	3.9	2.28	6.4	540
FAVB14*	147	16.8	16.8	11.2	10.4	5.2	3.04	8.2	720
FAVB15*	183	21.0	21.0	14.0	13.0	6.5	3.80	10.1	900
FAVB16*	219	25.2	25.2	16.8	15.6	7.8	4.56	12.0	1080
FAVB17*	262	29.4	29.4	19.6	18.2	9.1	5.32	13.9	1260
TWO FAN WIDE UNITS									
-	-	-	-	-	-	-	-	-	-
FAVB22*	75	16.8	16.8	11.2	10.4	5.2	3.04	8.5	700
FAVB23*	111	25.2	25.2	16.8	15.6	7.8	4.56	12.3	1050
FAVB24*	147	33.6	33.6	22.4	20.8	10.4	6.08	16.1	1400
FAVB25*	183	42.0	42.0	28.0	26.0	13.0	7.60	19.9	1750
FAVB26*	219	50.4	50.4	33.6	31.2	15.6	9.12	23.8	2100
FAVB27*	262	58.8	58.8	39.2	36.4	18.2	10.64	27.5	2450

* Model number shown does not include rows or fins per inch.

** For unit Minimum Unit Circuit Amps (MCA) and Maximum Unit Overload (MOP) Consult the factory wiring diagram supplied with the unit.

3 UNIT LOCATION

Fluid Coolers require adequate space around them to allow unrestricted ambient airflow in to and out of the fan section. Figure 3 gives general rules as to the location of a fluid cooling unit with regard to different situations. The distances shown in the sketches should be increased whenever possible. The unit position relative to the prevailing winds should be taken into account. Note that higher than expected return fluid temperatures will result in poor system operation if the following suggested distances are not used.

So that a unit performs as predicted it should be located away from heated air exhausts, steam vents, or corrosive airflow, whether it comes from the user site, or from another nearby source. A corrosive atmosphere will require a coil coating, if available for the corrosive.

Unit sound levels should be considered for the unit location. A fluid cooling unit should be located away from sound and vibration sensitive spaces to avoid transmission into those spaces.

FIGURE 3 LOCATION REQUIREMENTS

Walls or Barriers

For proper airflow and access, all sides of the unit should be a minimum of “W” away from any wall or barrier. Enough space should be allowed for all maintenance work. Overhead obstructions are not allowed.

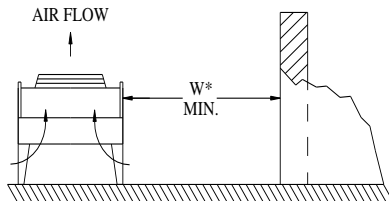

Multiple Units

For units placed side by side, the minimum distance between units is the width of the largest unit. If units are placed end to end, the minimum distance between units is one fan section long.

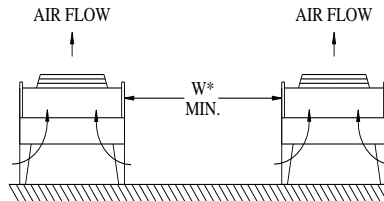

Walls or Barriers for Horizontal Airflow

Units with horizontal airflow should be a minimum of “W” away from any wall or barrier, plus the air discharge should be free flowing away from the unit.

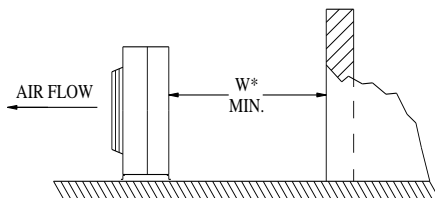

Decorative Fences

Fences must have 50% free area, with 1 foot undercut, a “W” minimum clearance, and must not exceed the top of the unit.

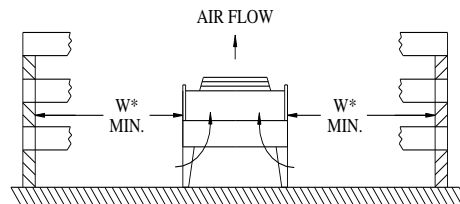

W = Total width of the Fluid Cooling unit – Single or Double wide.

4 RIGGING

Fluid Coolers are designed to be lifted using the leg support channels or the side lifting brackets for larger units. The unit mounting leg assemblies are best attached when the unit is in the flat, fans facing up, and supported by the rigging. Take special care not to bump, hit, or otherwise stress the tubing, headers, or connections during the lifting and positioning of the unit. Under no circumstances should the coil headers or return bends be used in lifting or moving the unit. See Figures 4 and 5 for the designated lifting points and lift methods for all unit sizes, plus approximate unit weights.

FIGURE 4 RIGGING AND LIFTING FOR 30" FAN UNITS

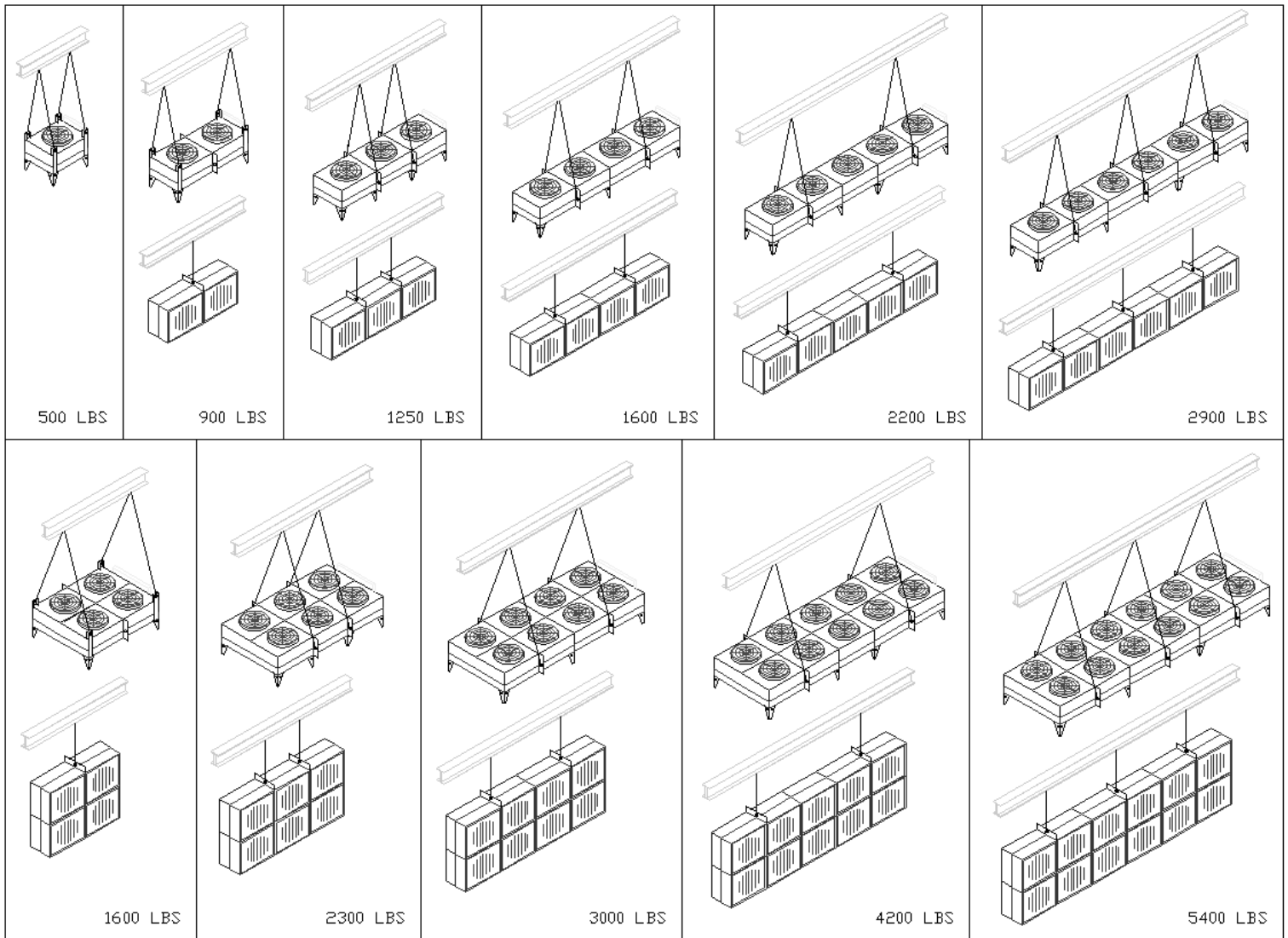

STATIONARY LIFTING POINTS AND LIFTING PLATES FACTORY MOUNTED. OUTER SUPPORT LEGS (IF REQUIRED) SHIPPED LOOSE FOR FIELD INSTALLATION BY OTHERS WITH NECESSARY BOLTS, WASHERS AND NUTS INCLUDED, (SEE SECTION 5.1 FOR LEG MOUNTING INSTRUCTIONS). UNDER NO CIRCUMSTANCES SHOULD MANIFOLDS, ELECTRICAL ENCLOSURE(S) OR RETURN BENDS BE USED FOR LIFTING OR MOVING THE UNITS!

FIGURE 5 RIGGING AND LIFTING FOR 24" FAN UNITS

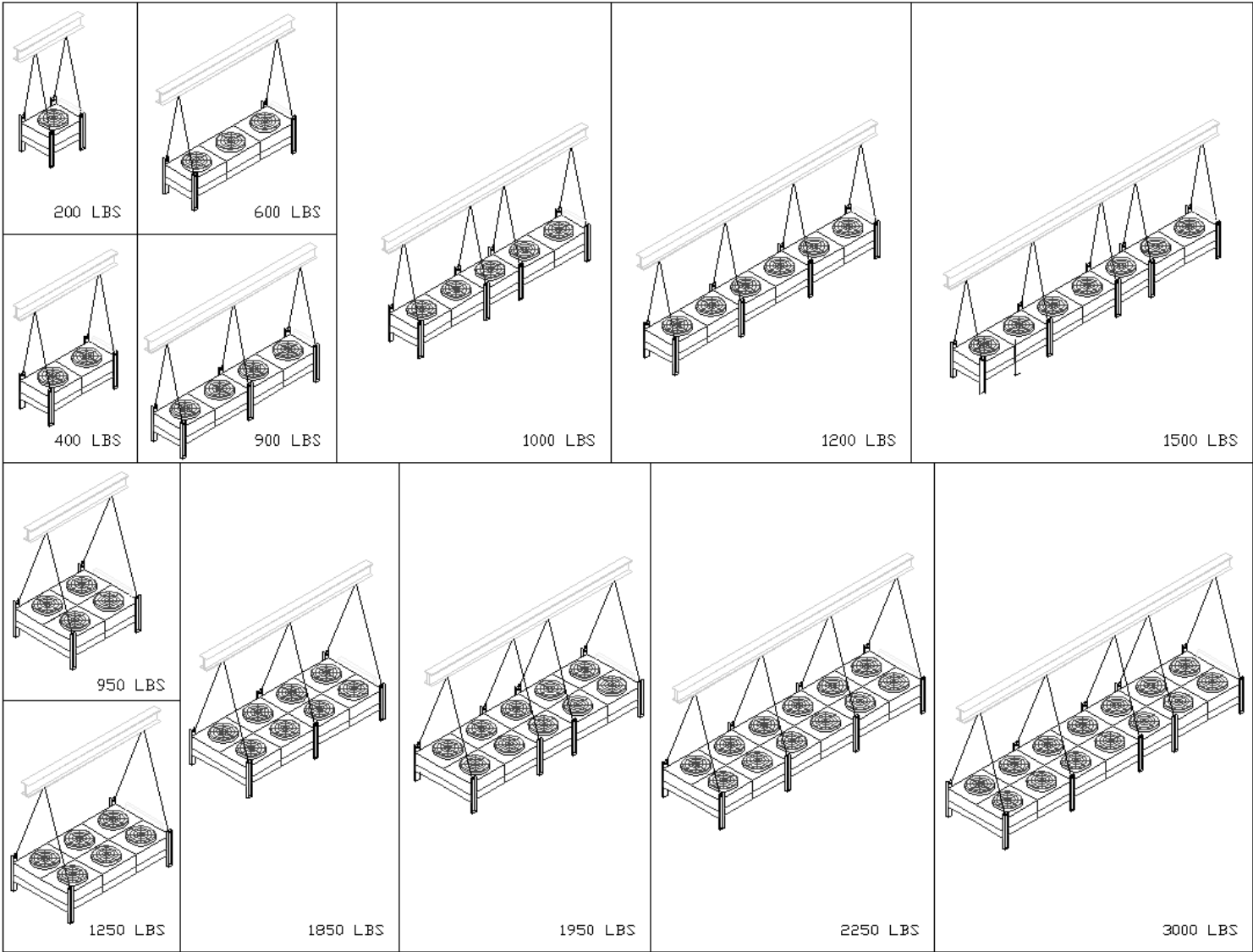

STATIONARY LIFTING POINTS AND LIFTING PLATES FACTORY MOUNTED. OUTER SUPPORT LEGS (IF REQUIRED) SHIPPED LOOSE FOR FIELD INSTALLATION BY OTHERS WITH NECESSARY BOLTS, WASHERS AND NUTS INCLUDED, (SEE SECTION 5.1 FOR LEG MOUNTING INSTRUCTIONS). UNDER NO CIRCUMSTANCES SHOULD CONSIDER MANIFOLDS, ELECTRICAL ENCLOSURE(S) OR RETURN BENDS BE USE FOR LIFTING OR MOVING THE UNITS!

5 UNIT ASSEMBLY

5.1 Leg Assembly For 30" Fan Units

Fluid Coolers with 30" diameter fans that will blow air in a vertical up direction are supported by formed, mill galvanized, channel legs that provide a standard 22" of clearance from the bottom of the leg to the bottom of the coil section. Install the legs on the unit before rigging the unit into place using the hardware provided with the unit. If extended legs are ordered to provide additional clearance, the leg attachment is the same as the standard leg. Support legs that are 48" or 60" in height will require a leg between every fan section and cross bracing for stability.

FIGURE 6 STANDARD 22" & 42" LEG ASSEMBLY

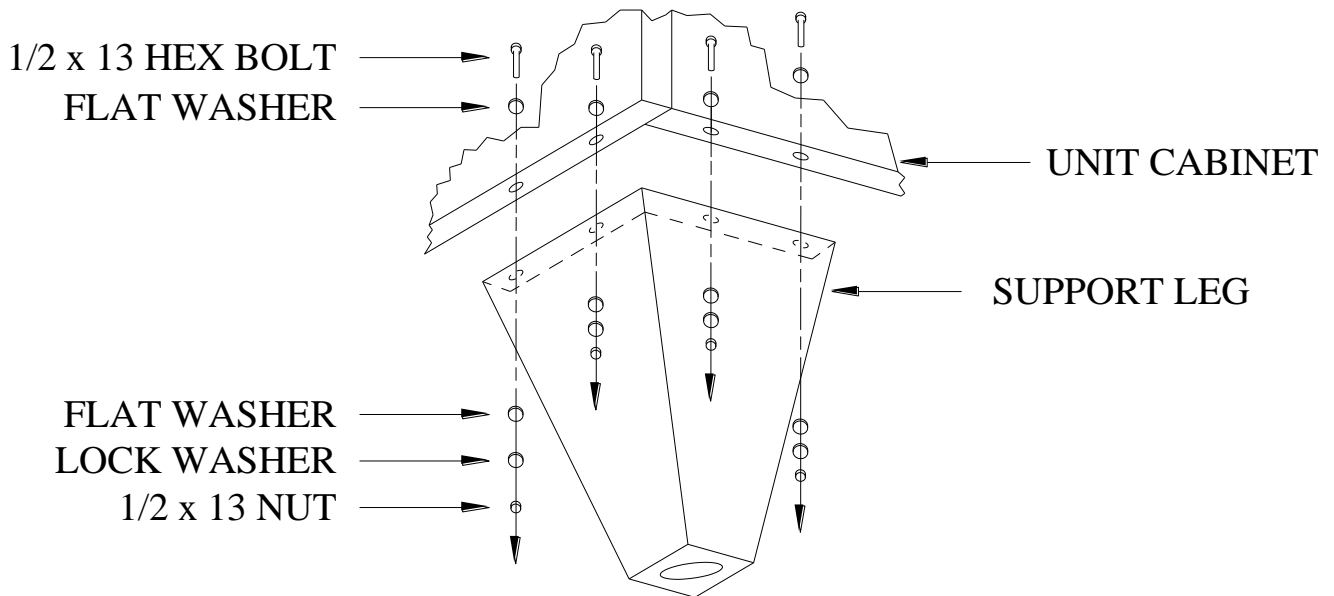

5.2 Horizontal Airflow Unit

Double-wide Fluid Cooler units with 30" diameter fans standing up with horizontal airflow will have heavy duty sheetmetal supports running the length of the unit to support the weight of the unit. The supports have a hole pattern to bolt the unit to the base pad or structure that the unit will sit on, see the drawing that comes with the unit for the hole pattern detail. The unit will also come with a loose set of metal angles to help support the unit horizontally. See the drawing that comes with the unit for support angle attachment location both to the unit and to the base pad or structure.

6 INSTALLATION AND PIPING

6.1 *Mounting The Unit*

The unit must be installed on a firm, level base to assure optimum unit performance. The mounting legs should be securely fastened at their base to the steel or concrete of the supporting base. For roof mounted installations, the steel supporting base holding the unit should be elevated above the roof and fastened to the columns or load bearing walls of the building. See Figure 8 for mounting examples.

6.2 *Interconnecting Piping For Double Wide Units*

Interconnecting piping for double-wide units should be as short and as direct as possible to the unit header connections. The fluid inlet connections are always on the air outlet side of the coil. If the fluid piping arrangement has a portion of the pipe at a higher elevation than the coil headers, a vent valve should be placed at the highest point of the piping. If the header sheetmetal covers were removed for piping, replace the covers for header and return bend protection. See Figure 8 for suggested interconnecting piping support arrangements.

6.3 *Fluid Piping*

All jobsite piping to the unit should conform to the applicable local and state codes. Use the proper pipe sizes for the installation. Follow good commercial piping practices throughout the installation, which includes properly bracing the lines.

AC&R type copper tubing should be used throughout. Cut tubing with a wheel-type cutter and not a hacksaw. Debur before assembly in the fittings. NOTE: If the on site tubing lengths to be used were not capped (i.e., are not perfectly clean) they should be dragged internally with a clean, lint-free rag before fabricating into the system. Soft solders are not to be used. Always clean all pipe and fitting areas that will be brazed with the proper grade emery cloth. Plan to use only oxy-acetylene brazing. A higher content silver brazing rod must be used to avoid excessive use of flux, to avoid it being pushed into the system piping, which will create problems at a later date. Use a silver solder which contains sufficient silver content necessary for joint strength and flexibility, yet requires minimum use of flux. For copper-to-copper joints, use a phos-copper solder with 6-8% silver content. Some easy-flow types require no flux, and the resultant joints are of maximum strength without brittleness. Nitrogen should be used to purge the air from the connecting tubing during brazing in order to prevent copper oxide formations.

For fluid coolers with threaded connections use of a pipe thread compound (filler) or Teflon tape is recommended when connecting to the system piping. Use opposing wrenches on the unit connection and the mating piping connection so that the minimum of the turning torque is applied to the unit connection stub and header.

For fluid coolers with flanged connections the mating flange must be equally rated and sized. See the drawing that came with the unit for the flange information.

A vent plug is installed at the highest point in the unit inlet header to facilitate the removal of internal air when filling or purging the system. The purging process should only be done with the pump system off and pressures equalized.

Consideration should be given that undersizing piping lines will cause a number of problems in a fluid system. High pressure drop in the lines take away from the systems flow rate and capacity as well as resulting in excessive power usage.

Provisions must be made to accommodate expansion and contraction of the lines, especially if the lines have long runs with few elbows or bends. The lines must also be adequately supported at frequent intervals in accordance with good piping practice. It is necessary that field bracing provide adequate support at the Fluid Cooler connections. See Figure 8 for suggested arrangements.

Pressure testing of the piping should be done as soon as the field piping has been completed. The test pressure should not exceed the unit UL nameplated pressure. Nitrogen may be used to increase the trace refrigerant pressure for leak testing. Shipping vibrations can stress joints, thus producing operating leaks, which would otherwise go undetected from just a low pressure holding charge. Therefore, check for leaks at all joints, field and factory, before filling the system.

Field piping design must prevent the coil from being isolated from the expansion tank. See Figure 9 for typical piping. The fluid properties and circulation rate must be maintained to protect freezing.

FIGURE 8 UNIT MOUNTING AND PIPING

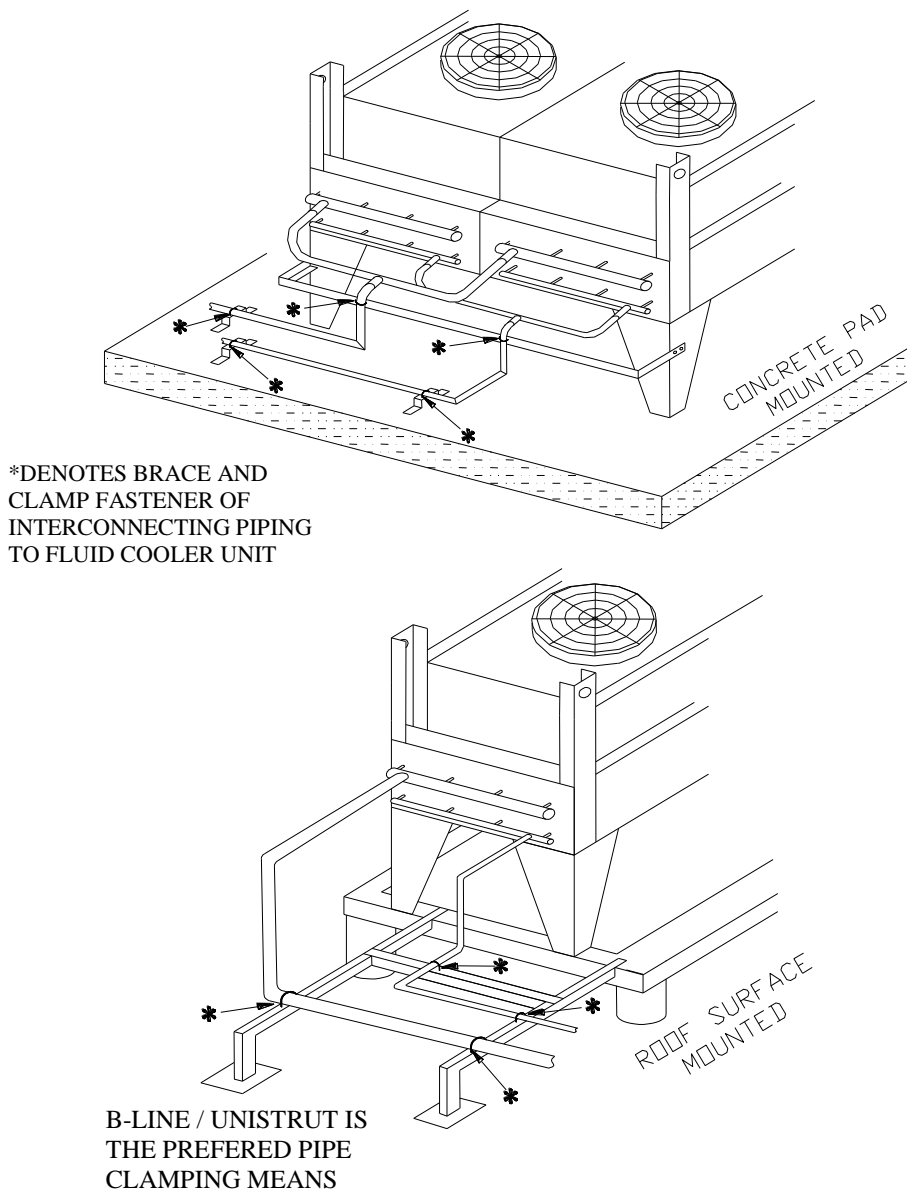
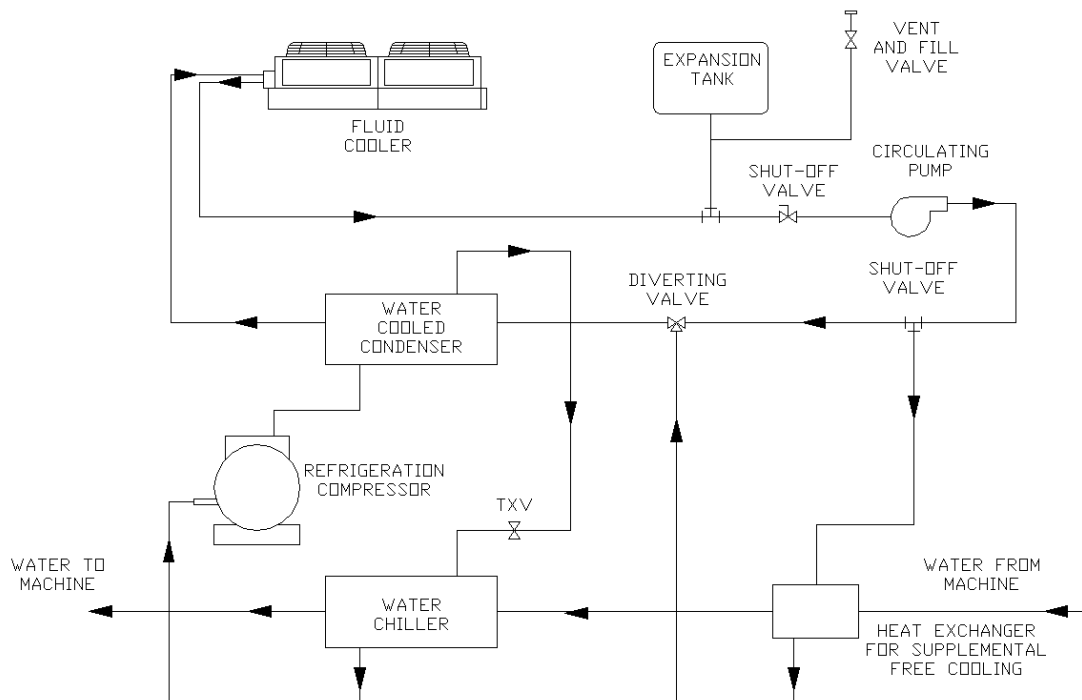

FIGURE 9 TYPICAL PIPING



7 ELECTRICAL

If the Fluid Cooler unit is equipped with an electrical power disconnect switch make sure the switch is in the “OFF” position, preferably locked in this position, before any electrical work is performed to the unit.

The Fluid Cooler unit can be arranged at the factory so that each motor is wired to individual terminal blocks, in which case each motor requires individual power wiring, or the motors can be wired to a fan cycling control panel which requires only one set of power wires. The fan cycling control panel can consist of a series of temperature controllers, which sense the outlet fluid temperature which turns fans on & off. See the electrical drawing that accompanies the unit for details.

Check fan blade clearances within the venturies so that each fan is horizontally centered in the venturi. Fan motors operating at higher elevations will draw lower than rated amps, as well as draw a less effective air volume across the coil surface. This is due to the reduced density of the higher altitude air resulting in reduced unit capacity. Consult factory if you suspect this situation.

7.1 Field Wiring

Field wiring should comply with NEC and local codes. The power supply voltage, phase, and frequency must match what is shown on the unit data plate. Only qualified electricians should work on the electrical portion of any unit installation.

7.2 Motors Wired To Terminal Blocks

Figure 10 shows typical unit wirings to terminal blocks. Fan motors are turned on and off by controls outside of the unit and by others.

FIGURE 10 TERMINAL BLOCK ONLY WIRING DIAGRAMS

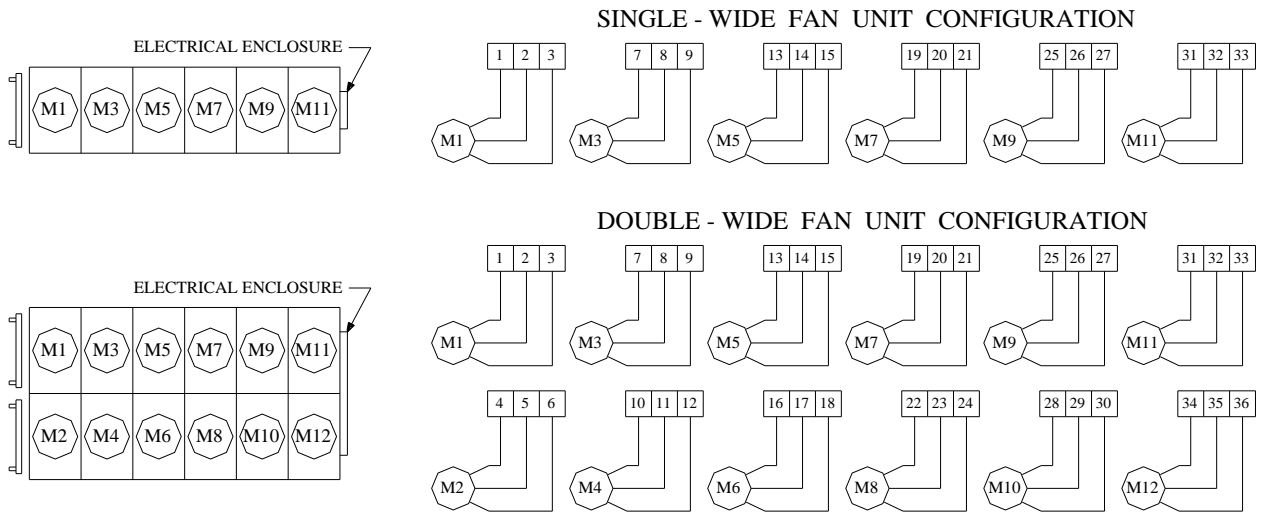

7.3 Motors Wired To Standard Fan Cycling Control Panel

The standard fan cycling control panel for Fluid Cooler units contains a series of temperature controllers. The fans cycle on and off from a signal by the temperature sensor. If the unit has one row of fans the fan cycling controls turn the fans on or off individually, but if the unit has two rows of fans either adjoining pairs of fans or individual fans can be cycled depending upon the system requirements. Consult the electrical drawing that arrived with the fluid cooler. The fan(s) nearest the headers are the first-on, last-off, and are continuously on when the pump is running. Figure 11 has typical motor wiring schematics.

FIGURE 11 FAN CYCLING WIRING DIAGRAMS (-311)

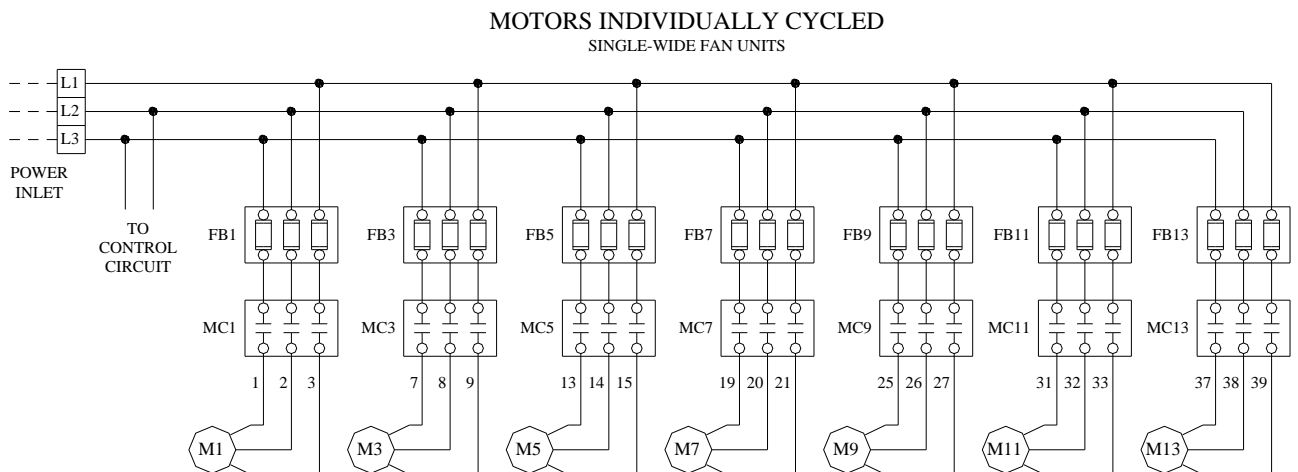

FIGURE 12 FAN CYCLING IN PAIRS WIRING DIAGRAMS (-331)

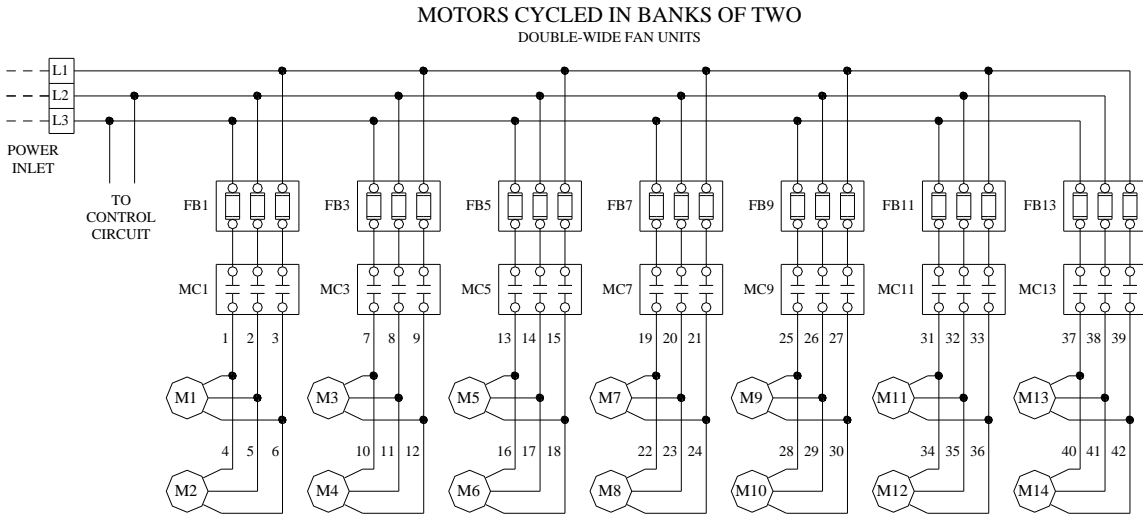
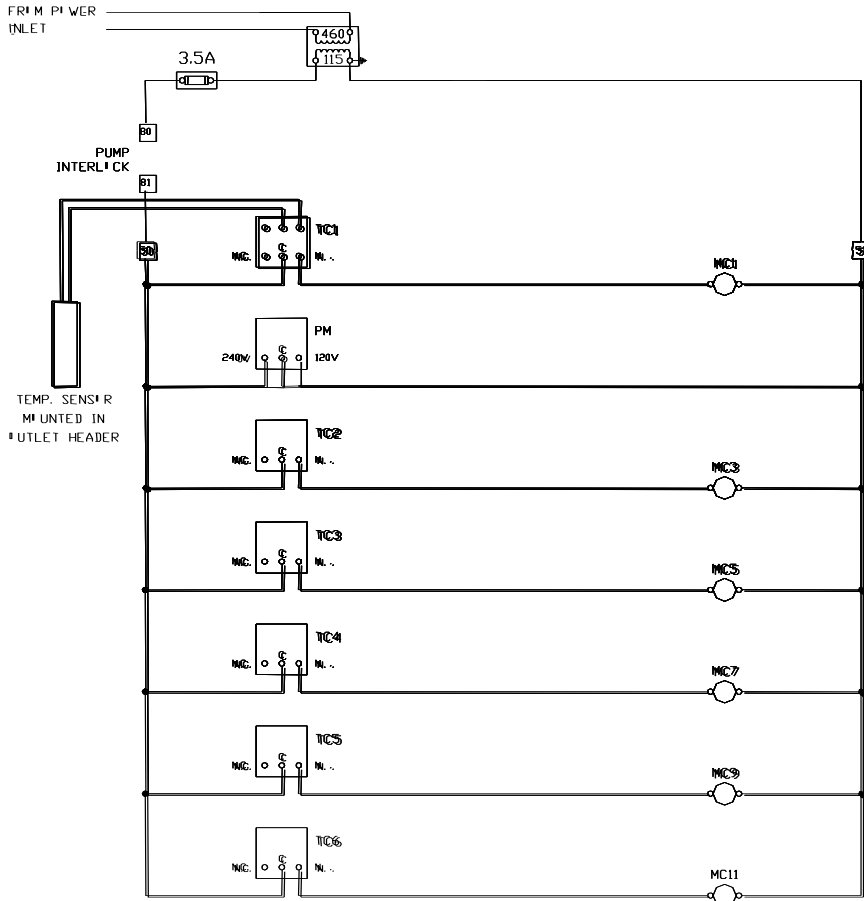

FIGURE 13 CONTROL PANEL WIRING DIAGRAMS



7.4 Fan Cycle Operation

The operation of the fan cycle controller employed with a fluid Cooler unit should be set up so that the fan, or set of fans if a double wide unit, nearest the unit headers is/are the first fans on, or last-off, whenever the pump is running.

Not complying with this condition can cause uneven rapid expansion and contraction of the unit core tubing, contributing to tube failures. Violation of this condition is most often associated with electronic controllers and must be avoided through correct programming. This also means do not program the “header end” fans(s) for “equal run time”.

The excessive tube stress within the unit, due to rapid expansion and contraction of the coil, is caused by needless temperature swings, which result from incorrect fan cycling during cold weather. The header end fan(s) will cool the entering fluid and allow the remaining unit surface to cool the fluid at internal temperatures that are not a threat to the performance of the equipment.

To obtain the maximum life from the unit, as well as meet with warranty stipulations, the following field set-up is required:

- A) Always set the header end fan(s) to cycle first-on and last-off when a pump is operating.
- B) Do not set the fans to cycle-on more than 30 times per hour. The maximum short cycling is one minute on, one minute off.

7.5 Control Settings

Table 5 contains the settings that the control panel components are set. If a type of control that is not the Johnson 350 series controller is used, consult the wiring schematic for the unit ordered.

7.6 Temperature Sensor

For units with factory-mounted fan cycling controls, the fluid temperature sensor is installed into the bottom, or fluid outlet, header to sense the discharge fluid temperature. On the end of the header, usually on the left side of the unit, a thermal well is installed into the header end-cap and the temperature sensor is installed in the bulb well.

TABLE 5 CONTROL PANEL SETTINGS

		AMBIENT CONTROL TEMPERATURE SETTINGS (°F)						
TEMPERATURE CONTROL #		TC1	TC2	TC3	TC4	TC5	TC6	TC7
FAN MOTOR CONTACTOR NUMBER	Single Wide Units	MC1	MC3	MC5	MC7	MC9	MC11	MC13
	Double Wide Units	MC1 & MC2	MC3 & MC4	MC5 & MC6	MC7 & MC8	MC9 & MC10	MC11 & MC12	MC13 & MC14
	SET	70						
	OFFSET	--						
	DIFF	15						
	FAN ON	85						
	FAN OFF	70						
	SET	60	--					
	OFFSET	--	15					
	DIFF	10	10					
	FAN ON	70	85					
	FAN OFF	60	75					
	SET	60	--	--				
	OFFSET	--	10	15				
	DIFF	10	10	10				
	FAN ON	70	80	85				
	FAN OFF	60	70	75				
	SET	60	--	--	--			
	OFFSET	--	5	10	15			
	DIFF	10	10	10	10			
	FAN ON	70	75	80	85			
	FAN OFF	60	65	70	75			
	SET	60	--	--	--	--		
	OFFSET	--	5	10	15	20		
	DIFF	5	5	5	5	5		
	FAN ON	65	70	75	80	85		
	FAN OFF	60	65	70	75	80		
	SET	55	--	--	--	--	--	
	OFFSET	--	5	10	15	20	25	
	DIFF	5	5	5	5	5	5	
	FAN ON	60	65	70	75	80	85	
	FAN OFF	55	60	65	70	85	80	
	SET	55	--	--	--	--	--	--
	OFFSET	--	5	10	15	20	25	30
	DIFF	5	5	5	5	5	5	5
	FAN ON	55	60	65	70	75	80	85
	FAN OFF	50	55	60	65	70	75	80

NOTE: MOTOR CONTACTORS WIRED TO "NC" CONTACT OF TEMPERATURE CONTROL.
TEMPERATURE CONTROL SET IN "HEATING" MODE. SEE WIRING DIAGRAM.

8 INSPECTION AND CLEANING

WARNING: All power to must be off, before opening any compartments, cleaning or performing maintenance.

If the Fluid Cooler unit is equipped with an electrical power disconnect switch make sure the switch is in the “OFF” position, preferably locked in this position, before any electrical work is performed on the unit. Without a disconnect switch on the unit, make sure all power to the unit is off from the source.

Electrical connections should be inspected periodically and tightened if required. Loose electric connections can cause severe electrical damage as well as nuisance tripout and burnouts.

For maximum efficiency, Fluid Coolers should be cleaned of lint and dust every 4 to 6 months so that airflow is not restricted. More frequent cleaning may be necessary under severe conditions. The cleaning force must be opposite the direction of the fan airflow direction. The Fluid Cooler unit is equipped with convenient access panel to allow a cleaning wand and nozzle to be inserted into the fan cabinet above the coil section and below the motors & fans.

9 REPLACEMENT PARTS LIST

Table 6 REPLACEMENT PART NUMBERS

ITEM	PART NO.
FEVA UNIT	
MOTOR: 1 HP 850 RPM 208-230/460/3/60	11503
1 HP 850 RPM 575/3/60	E205307
FAN: 30" DIA. CW 5/8" BORE	E208057
GUARD: FOR 30" FAN	E280792
FAVB UNIT	
MOTOR: 1/2 HP 1140 RPM 208-230/460/3/60	11525
1/2 HP 1140 RPM 575/3/60	E208100
FAN: 24" DIA. CCW 5/8" BORE	E206876
GUARD: FOR 24" FAN	E82691
FEVC UNIT	
MOTOR: 1 1/2 HP 850 RPM 208-230/460/3/60	E151976
1 1/2HP 850 RPM 575/3/60	E151976A
FAN: 30" DIA. CW 5/8" BORE	E208058
GUARD: FOR 30" FAN	E280792
FEVE UNIT	
MOTOR: 1/2 HP 575 RPM 208-230/460/3/60	E206880
1/2 HP 575 RPM 575/3/60	E318680
FAN: 30" DIA. CW 5/8" BORE	E205493
GUARD: FOR 30" FAN	E280792
FEVF UNIT	
MOTOR: 1 1/2 HP 1140 RPM 208-230/460/3/60	E205492
1 1/2 HP 1140 RPM 575/3/60	E208056
FAN: 30" DIA. CW 5/8" BORE	E205493
GUARD: FOR 30" FAN	E280792
MISCELLANEOUS	
MOTOR CONTACTOR	10748
A350AB-1 TEMPERATURE CONTROLLER	E205533
Y350 R-1 POWER MODULE	E205534
S350AA-1 ADDER MODULE	E205535
MOTOR MOUNT FOR 24" FAN UNIT (1 PER MOTOR)	82039
MOTOR MTG BRACKET FOR 30" FAN UNIT (2 PER MOTOR)	E208055
MOTOR MTG RING FOR 30" FAN UNIT (1 PER MOTOR)	80034
STD 18" SUPPORT LEG FOR 24" FAN UNIT	E281661
STD 22" TAPERED SUPPORT LEG FOR 30" FAN UNIT	80084
STD 42" EXTENDED SUPPORT LEG FOR 30" FAN UNIT	80540
MOTOR SERVICE PANEL	E86121