

HS Series

Bulletin: HS-1181

Supersedes: HS-1176

HS-ED-1176

HS-KG-HG-577

# KRACK Hite-Saver Unit Coolers

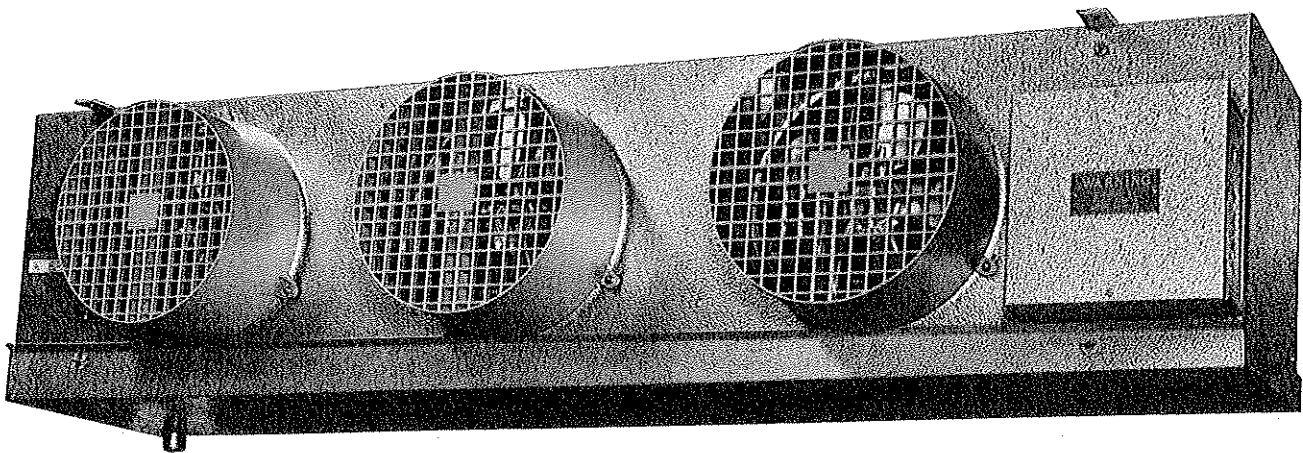

*Twenty-four Models 3500 to 45000 BTUH  
Air, Electric, or Hot Gas Defrost  
Low Silhouette—Long Air Throw  
Ideal For Walk-In Coolers and Freezers*

**Krack Corporation**

401 S. Rohlwing Road (Route 53) • Addison, Illinois 60101  
(312) 629-7500 • Telex 72-1435 • Cable: KRACKOIL



# SPECIFICATIONS

## CAPACITY DATA

7 FPI MED TEMP	CAPACITY BTUH		AIR CFM	NO FANS	WEIGHT—LBS		
	10°TD	15°TD			A	ED	KGE-HGE
HS-17-50	5000	7500	670	1	65	75	70
HS-27-100	10000	15000	1340	2	95	105	100
HS-37-150	15000	22500	2010	3	125	135	130
HS-47-200	20000	30000	2680	4	160	175	165
HS-57-250	25000	37500	3350	5	195	210	200
HS-67-300	30000	45000	4020	6	210	230	215

6 FPI MED TEMP	CAPACITY BTUH		AIR CFM	NO FANS	WEIGHT—LBS		
	10°TD	15°TD			A	ED	KGE-HGE
HS-16-45	4500	6750	680	1	60	70	65
HS-26-90	9000	13500	1360	2	90	100	95
HS-36-135	13500	20250	2040	3	120	130	125
HS-46-180	18000	27000	2720	4	155	170	160
HS-56-225	22500	33750	3400	5	190	205	195
HS-66-270	27000	40500	4080	6	205	225	210

5 FPI LOW TEMP	CAPACITY BTUH		AIR CFM	NO FANS	WEIGHT—LBS		
	10°TD	12°TD			A	ED	KGE-HGE
HS-15-40	4000	4800	690	1	55	65	60
HS-25-80	8000	9600	1380	2	85	95	90
HS-35-120	12000	14400	2070	3	115	125	120
HS-45-160	16000	19200	2760	4	150	165	155
HS-55-200	20000	24000	3450	5	185	200	190
HS-65-240	24000	28800	4140	6	200	220	205

4 FPI LOW TEMP	CAPACITY BTUH		AIR CFM	NO FANS	WEIGHT—LBS		
	10°TD	12°TD			A	ED	KGE-HGE
HS-14-35	3500	4200	700	1	50	60	55
HS-24-70	7000	8200	1400	2	80	90	85
HS-34-105	10500	12600	2100	3	110	120	115
HS-44-140	14000	16800	2800	4	145	160	150
HS-54-175	17500	21000	3500	5	180	195	185
HS-64-210	21000	25200	4200	6	195	215	200

## ELECTRICAL DATA

ANY MODEL	FAN MTR AMPS		ELECTRIC DEFROST HEATER AMPS				WATTS 230V	KGE-HGE PAN AMPS		WATTS 115V
	115/1	230/1	208/1	230/1	208/3	230/3		115/1	230/1	
HS-1	1.1	0.55	4.7	5.2	2.7	3.0	1200	2.6	1.3	300
HS-2	2.2	1.10	9.4	10.4	5.4	6.0	2400	5.2	2.6	600
HS-3	3.3	1.65	14.1	15.6	8.2	9.1	3600	7.0	3.5	800
HS-4	4.4	2.20	18.8	20.8	10.9	12.1	4800	8.7	4.4	1000
HS-5	5.5	2.75	23.6	26.1	13.7	15.1	6000	9.6	4.8	1100
HS-6	6.6	3.30	28.3	31.3	16.4	18.1	7200	12.2	6.1	1400

## COIL DATA

ANY MODEL	FACE AREA SQ FT	COIL VOL CU FT	REFRIG CHARGE LBS	LIQ FLARE	SUCT DDS	CONNECTIONS		KG-HG TEE & CHECK FLARE
						DRAIN FPT		
HS-1	1.7	0.08	1.8	1/2	5/8	3/4		1/2 x 1/2 x 3/8
HS-2	3.4	0.16	3.5	1/2	7/8	3/4		1/2 x 1/2 x 3/8
HS-3	5.1	0.23	5.2	1/2	7/8	3/4		1/2 x 1/2 x 3/8
HS-4	6.7	0.31	6.8	1/2	1-1/8	3/4		1/2 x 1/2 x 3/8
HS-5	8.4	0.38	8.5	1/2	1-1/8	3/4		1/2 x 1/2 x 3/8
HS-6	10.1	0.46	10.2	1/2	1-1/8	3/4		1/2 x 1/2 x 3/8

**Capacity Ratings** are based on sensible heat removal with a TEV fed, medium frosted coil when:

- SST (sat suct temp) is above -20°F  
Derate 10% for -30°F

- TEV superheat does not exceed 10°F above SST
- Med temp selection TD is from 10 to 15°F  
Low temp selection TD is from 8 to 12°F  
(TD is the temp difference between room and SST)

- Fan motor heat is not included in rating—add to room load—250 BTUH per fan
- Derate 12% for 50 HERTZ (0.88 mult) or increase TD to compensate for lower fan RPM—10 to 11.4° TD or 12 to 13.6° TD

# FEATURES

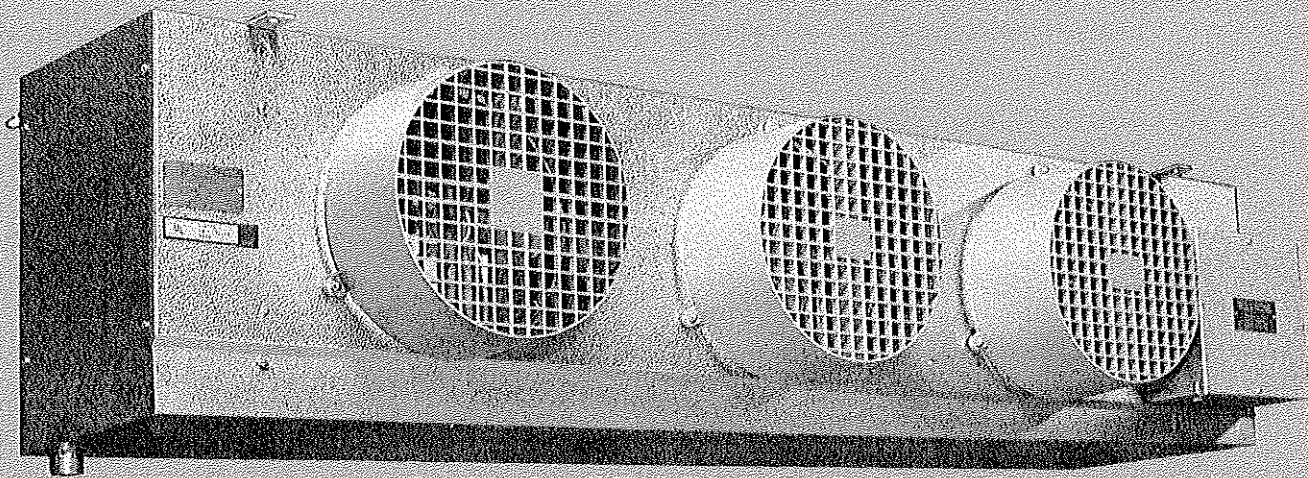

**Low-Silhouette** is ideal for 8 to 12 foot high coolers and freezers.

**High Efficiency** four row deep coils utilize 1/2" OD staggered copper tubes mechanically expanded into corrugated aluminum fins spaced by tube collars.

**Wide Fin Spacing** reduces air blockage caused by frost. Four and five fin/inch models are recommended for low temp. Six and seven fin/inch models are ideal for med temp.

**Automatic Defrost** with air, electricity or hot gas is available for all models.

**Housing and Drain Pan** are constructed of textured corrosion resistant aluminum. Top and front are one piece with removable end panels. Double pitched removable drain pans allow units to be hung level.

**Individually Compartmented** fan sections prevent reverse rotation in event of motor failure. Fans are 10 inch diameter and are located a proper distance from the coil to create efficient draw-thru air flow.

**TEAO Fan Motors** are totally enclosed with internal overheat protection and lifetime lubricated ball bearings. Motors have 16 watt output, 1550 RPM, are suitable for 115 or 208-230/1/50-60, and have plug-in receptacles for quick connection.

**Plastic Fan Guards** create 40-50 ft air throw.

**Low Sound Levels** range from 57 decibels generated by one fan units to 63 decibels produced by 6 fan units; as measured on the "A" scale, 6 feet in front of unit.

**Quick Disconnect Valve** is provided on the suction header for pressure gauge readings and/or flare connection to a pressuretrol.

## DESIGN STANDARDS

- UL Listed
- ASHRAE Testing Procedure
- ARI Rating Standard
- National Electric Code

## ACCESSORIES

- TEV Thermostatic Expansion Valve
- LSV Liquid Line Solenoid Valve
- SLHX Suction Liquid Heat Exchanger
- Defrost Time Clocks

# DIMENSIONS

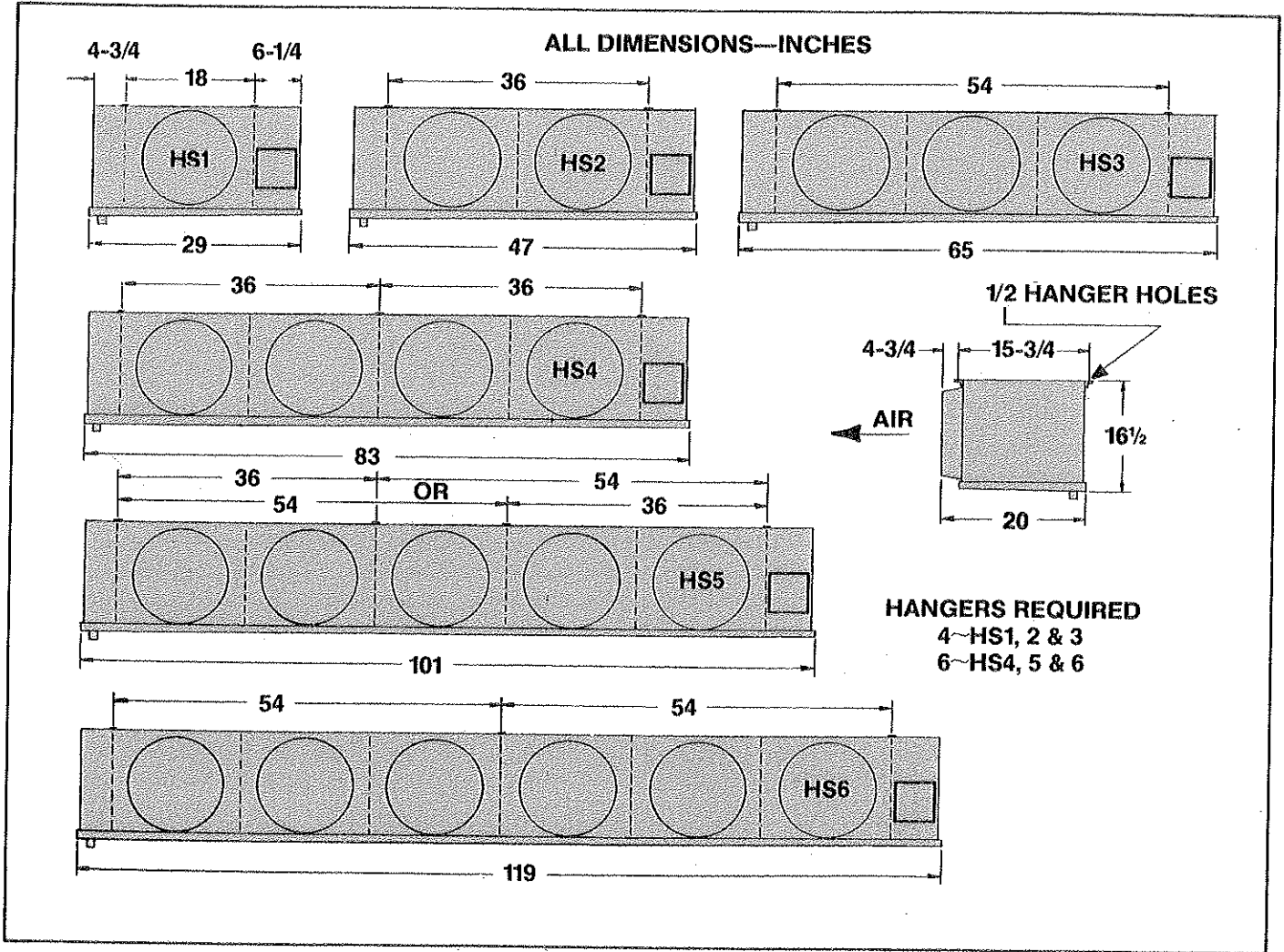

## MODEL KEY

HS-46-180-A  
 HS-35-120-ED  
 HS-54-175-KGE

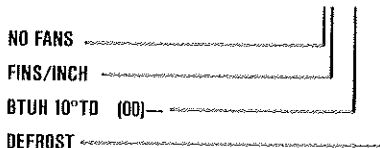

A —AIR  
 ED —ELECTRIC  
 KGE —2 PIPE HOT GAS  
 HGE —3 PIPE HOT GAS

## Please Specify:

- Complete Model Number
- Refrigerant—R12, R22, R502
- Room Temp
- Sat Suction Temp
- Electrical Characteristics  
 Motors—Heaters—Control Voltage
- Accessories

We reserve the right to change or revise specifications and product design in connection with any feature of our products. Such changes do not entitle the buyer to corresponding changes, improvements, additions or replacements for equipment previously sold or shipped.

**Application** of Hite-Saver unit coolers is recommended in small walk-in coolers and freezers above  $-20^{\circ}\text{F}$  with ceiling heights up to 12 feet. Air throw is 40-50 ft. Locate units 9 inches from walls for best results. Support piping adequately with suction line "P" traps at unit. Locate LSV close to TEV. Condensate drain lines must be adequately heat traced in rooms below freezing. Use externally equalized TEV except for HS-1.

Units circuited for water, glycol brines, or recirculated halocarbon systems are available.

# ELECTRIC DEFROST

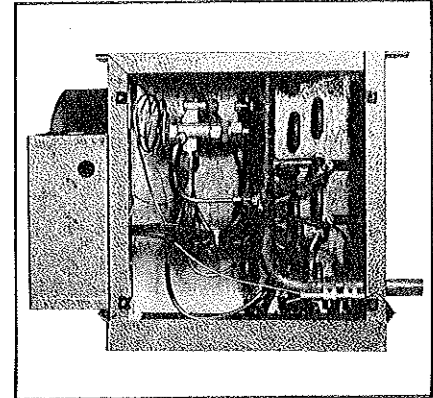
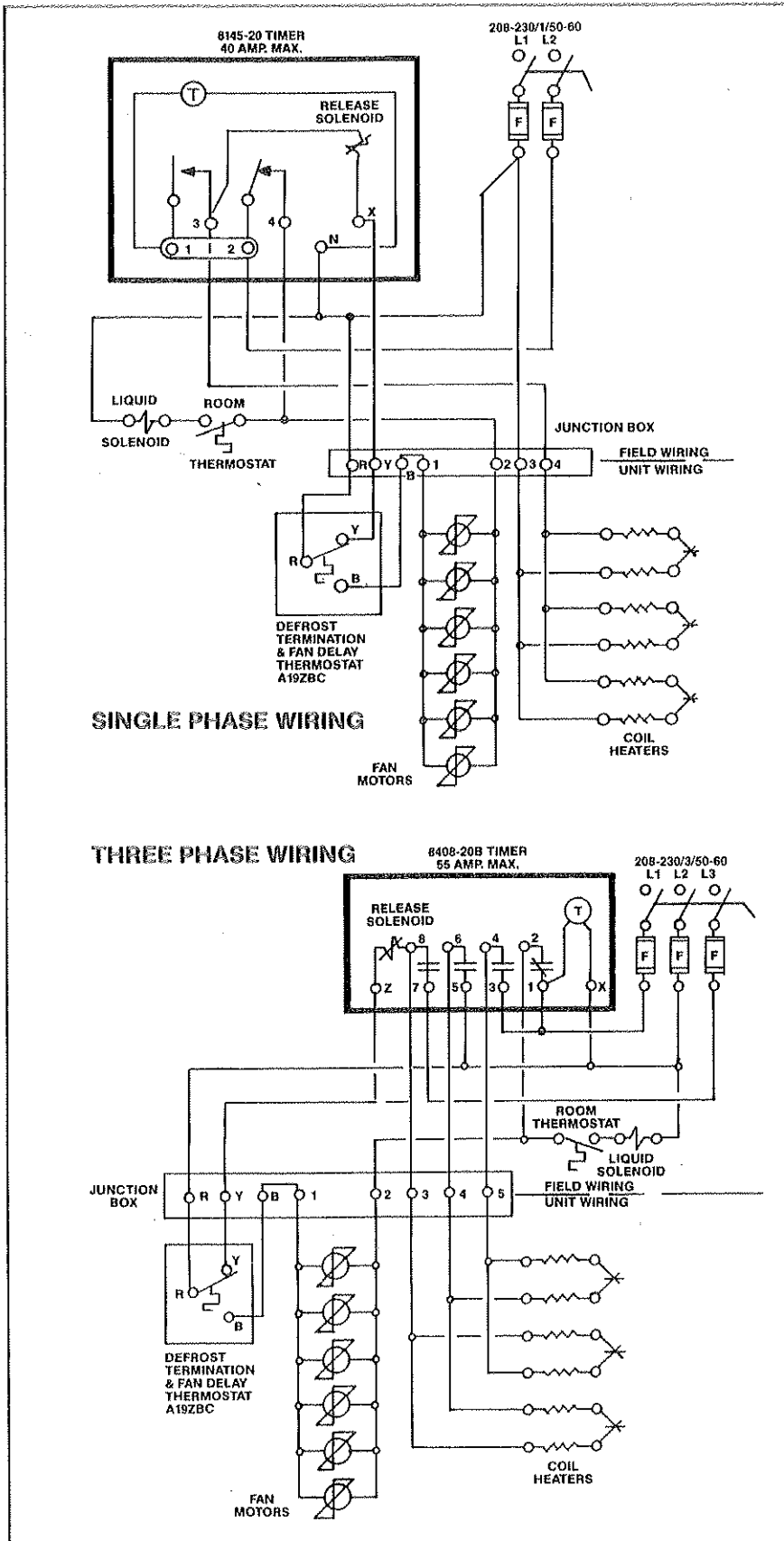

Efficient stainless steel tubular heaters rated for 115 volts, are inserted in fin grooves, two on the face and four on the coil bottom. Heaters are replaceable from the face or by removing the drain pan. Standard electric defrost configuration is with 208-230/1/50-60 fan motors and heaters wired for 230 volt, single or three phase. If 208 volt or lower power abnormally extends defrost cycles, three phase heaters are easily reconnected in star to obtain 230 volt wattage.

Defrost cycles are time clock initiated and temperature terminated by a factory mounted adjustable thermostat which creates a fan re-starting delay preventing warm air and condensate from being discharged into the space. The timer has a fail-safe feature. Its time setting is longer than necessary resulting in a second termination if the thermostat should fail. When defrosting two Hite-Savers at one time with one time clock; temp termination thermostats must be wired in series.

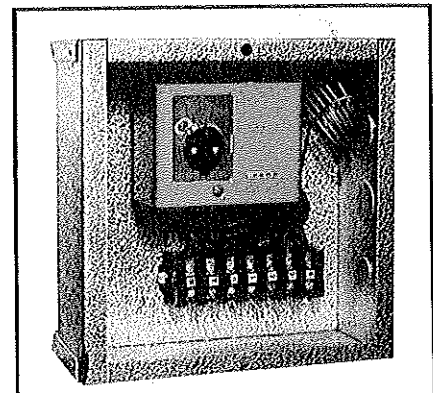

# HOT GAS DEFROST

## Reverse Cycle (2 pipe) systems

distribute compressor discharge gas thru the suction line during defrost. Defrost condensate is relieved thru a check valve, by-passing the TEV and LSV, to the liquid line which is reduced in pressure.

Hot gas flared tees and check valves are provided for field assembly with each unit. Defrost cycles are time clock initiated and terminated. A factory mounted pressure switch; senses the rise in suction line pressure; cycles fans off and energizes a drain pan stainless steel tubular heater. A temperature sensing klixon; located in a coil return bend; senses when the coil has been re-cooled after termination; and cycles the fans on. Pan heaters will have been deenergized by the pressure switch.

All models require one 15 amp, 115 or 208-230/1/50-60 circuit adequately protected.

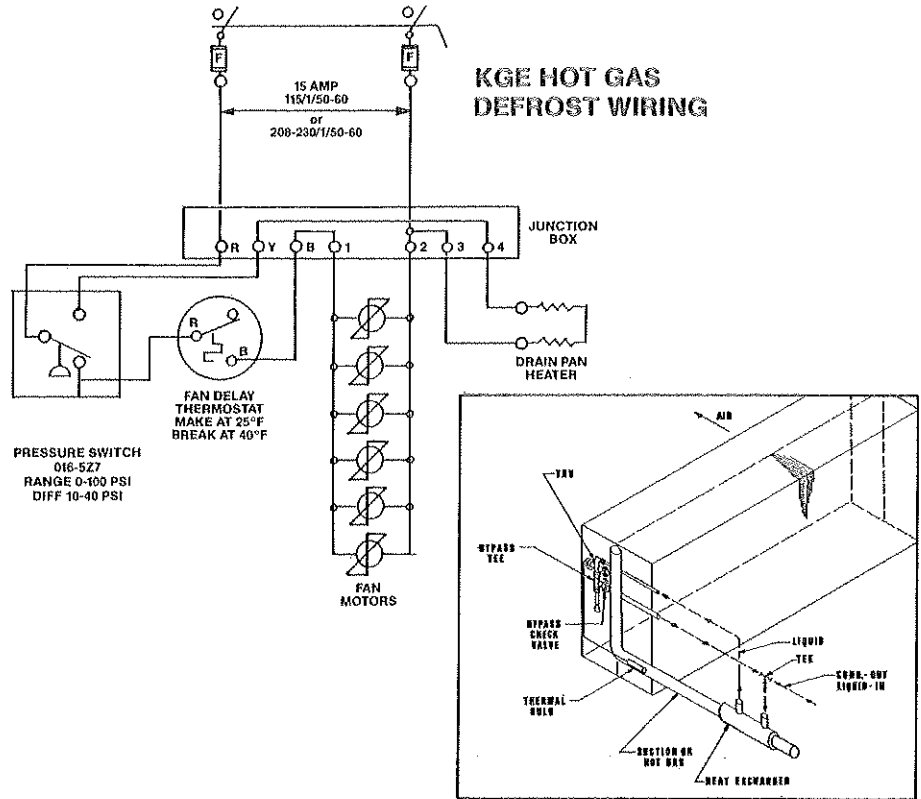

**Three pipe systems** distribute compressor discharge gas in a separate hot gas line, controlled by a solenoid valve, thru a check valve to the liquid distributor tee inlet. Defrost condensate and gas blow-by is collected in a suction trap which may meter liquid to a semi-hermetic compressor suction.

Defrost cycles are time clock initiated and terminated. The clock cycles fan motors, drain pan heater, and hot gas solenoid. Suction pressure control may be required to maintain defrost pressure above 40°F or to control compressor crankcase pressure.

