

KRACK

KPI Indoor Krack-Pak Systems

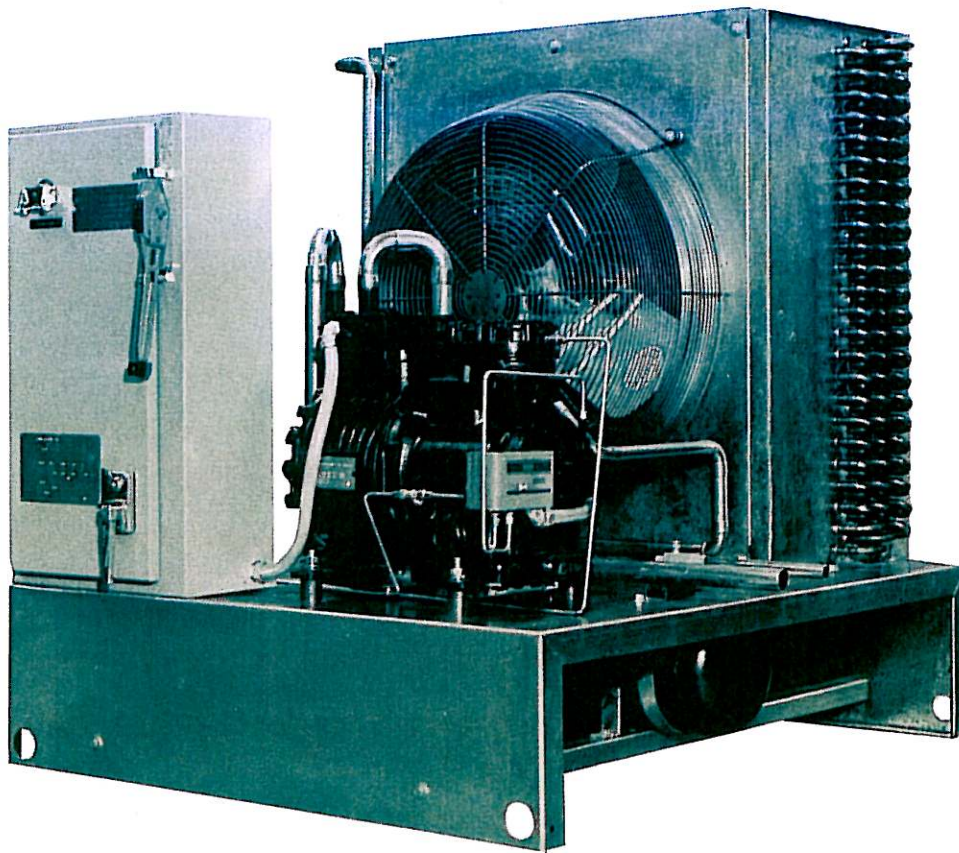

*KPI Indoor Air-Cooled Condensing Systems,
2 H.P. thru 20 H.P. High, Medium, and Low
Temperature Applications Using
R-12, R-22, R-502 Refrigerants*



STANDARD FEATURES

Compressor

Semi-hermetic, multi-cylinder, reciprocating type with refrigerant cooled motor including:

- Three phase internal motor overheat protection
- Anti-short cycle two minute delay—4 cylinder models
- Crankcase heater
- Oil level sight glass
- Internal shaft driven oil pump—3 HP and larger
- Back-seating suction and discharge service valves
- Manual reset oil failure safety switch
- Manual reset high discharge pressure switch
- Automatic reset low suction pressure switch
- Cylinder head cooling fans on R502 low temp models

Compressors are factory balanced and rigid mounted to reduce risk of line fatigue failure. Safety switches are piped with cadmium plated seamless steel tubing.

Condenser

Horizontal air flow, with coils constructed of copper tubes, with ten aluminum fins per inch. Liberal surface is adequate for 105°F ambients.

Quiet aluminum propeller fans are direct driven by 1/2 HP, weather resistant motors with sealed ball bearings and internal three phase overheat protection.

Receiver

Amply sized to allow for evaporator pumpout and condenser flooding charges. A 400 psi relief valve and backseating liquid service valves are included.

Minimum Head Pressure Low Ambient Control

Automatically allows reduced

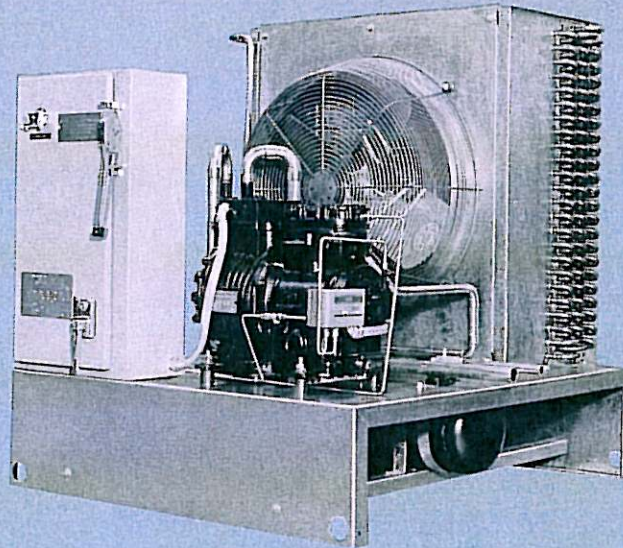

compressor discharge pressure coincident with lower ambients, minimizing power consumption. A minimum receiver pressure is maintained to distribute liquid to the thermostatic expansion valve fed evaporator.

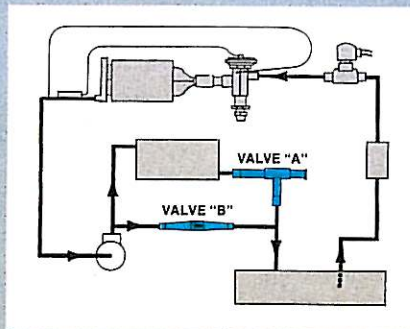

Valve "A" (adjustable from 65 to 225 psig) throttles condensate flow. As the condenser floods, its condensing capacity is reduced maintaining a minimum system head pressure.

Valve "B" maintains a differential pressure of 20 psi between the compressor discharge and the receiver. On start-up, receiver pressure builds rapidly to 20 psi below the setting of Valve A.

All but one condenser fan, are cycled by adjustable pressure switches.

Typical Valve A Settings:

Refrigerant	12	22	502
Room Temp	35	35	-10
PSIG	100	140	110

Suction Accumulator

Minimizes compressor failure caused by liquid or oil slug-backs.

Control Panel Includes:

- Weather resistant enclosure
- Main power circuit breaker with door mounted handle
- 115 volt control circuit transformer
- Safe-start system
- Compressor and condenser fan contactors
- Terminals, fuses, and relays
- Optional Matched System evaporator controls

Applicable Standards

The units are constructed in accordance with ARI, ASME, ANSI-B9, ASHRAE, UL, and the National Electric Code.

Shipment

The units are pressure tested and evacuated to 500 microns. Units are shipped with a dry nitrogen and refrigerant holding charge.

We reserve the right to change or revise specifications and product design in connection with any feature of our products. Such changes do not entitle the buyer to corresponding changes, improvements, additions or replacements for equipment previously sold or shipped.

°F
8°C

000
000

000
000

000
000

000
000

000
000

°F
8°C

-

-

-

-

°F
6°C

000
000

000
000

000
000

000
000

°F
°C

000
500

000
000

000
000

000
000

000
000

000
000

ELECTRICAL CONTROL

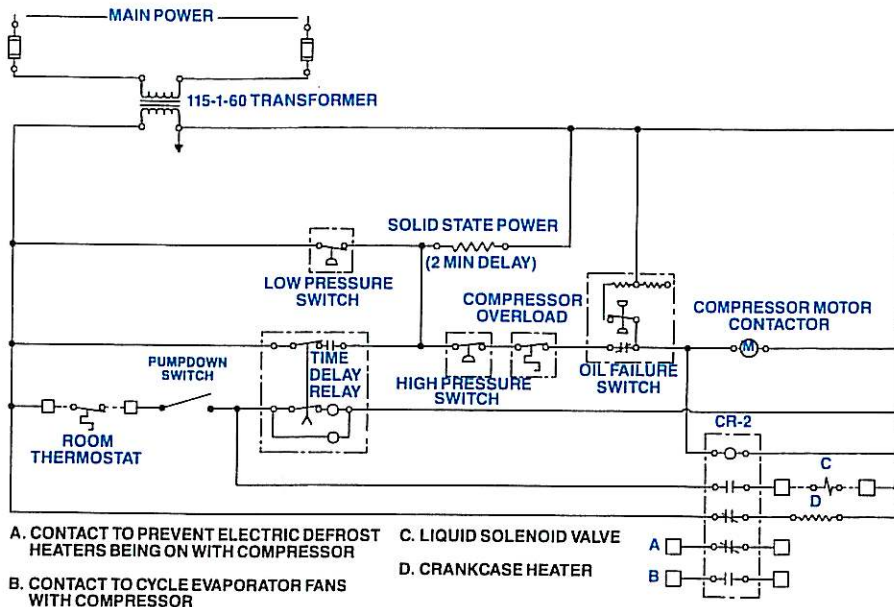

THE ABOVE SCHEMATIC HAS BEEN SIMPLIFIED FOR CLAIRTY. CONTACT FACTORY FOR YOUR TAILOR MADE WIRING DIAGRAMS.

Safe-Start System

- Allows compressor, liquid solenoid valve and evaporator fan motors to be energized by the room thermostat.
- Allows automatic pumpdown to a low pressure switch setting 10 to 20°F below design suction temperature. This reduces oil foaming. Pumpdown below compressor design suction conditions, even in cold ambients, is eliminated.
- Prevents compressor short cycling due to insufficient or loss of refrigerant charge.
- Short cycle protection is provided in larger compressors with solid state overload modules. A fixed timer will allow the system to start only after a two minute delay.

Start-Up Cycle

After closing the door mounted circuit breaker and pumpdown switch, the system will start if the thermostat (or other control sensor) calls for cooling. The adjustable time delay relay by-passes the low pressure switch to allow the system to establish head and suction pressure.

Shutdown Cycle

When the room thermostat (or control sensor) is satisfied or the door mounted pumpdown switch is opened, the liquid solenoid closes. The system will pumpdown to the low pressure switch setting and shut down. Refrigerant capacity of the evaporator plus the low ambient charge should not exceed the pumpdown capacity of the receiver.

Optional Factory Mounted Unit Cooler Controls

Air Defrost

A time clock will cycle the compressor off at selected intervals to allow the unit cooler fans to circulate room air (above 35°F) over the coil. See application guidelines.

Electric Defrost

A time clock will cycle the compressor off, stop the fan motors and energize the defrost heaters at selected intervals. Unit cooler fan motor and defrost heater contractors are provided. An adjustable temperature control or time control returns the system to the refrigeration cycle. A lock-out relay prevents the compressor and defrost heaters from operating simultaneously.

SELECTION

KPI Air-Cooled Systems

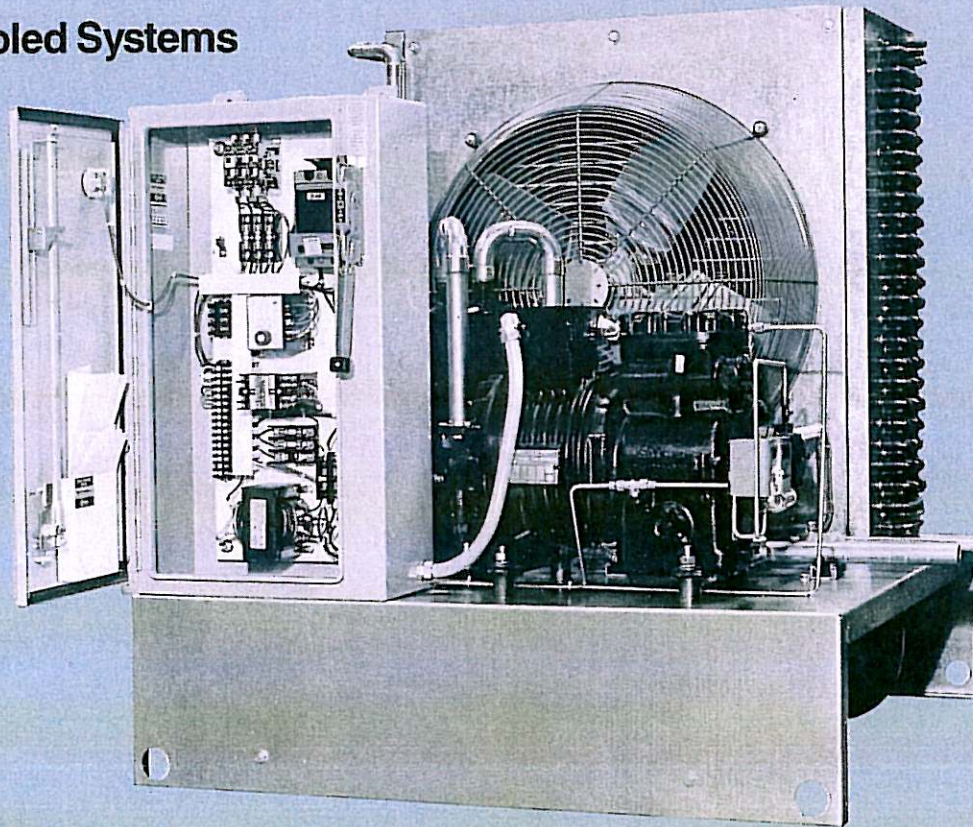

System Selection must result in compressor operation within the suction temperature ranges listed in the Model Key. Crankcase pressure regulators may be necessary if compressors are to be operated above rated suction temperature for long periods. Pressure limiting thermostatic expansion valves are recommended for low temperature evaporators.

Electrical Characteristics

208/230-3-60 or 200/220-3-50
460-3-60 or 380/400-3-50
575-3-60 or 500-3-50

Conversion Factors

BTUH @ 60 HZ x 0.83 = BTUH
@ 50 HZ
BTUH @ 60 HZ x 0.252 = K-CAL/HR
@ 60 HZ
BTUH @ 60 HZ x 0.210 = K-CAL/HR
@ 50 HZ
Pounds x 0.454 = Kilograms
Inches x 25.4 = Millimeters

Options

- Oversized condensers for high ambient operation.
- Factory installed Matched System controls.
- Filter drier with replaceable cores.
- Single phase (230 volt) for 2 HP and 3 HP units.
- Disposable drier.
- Dry-eye sight glass.

Model Key

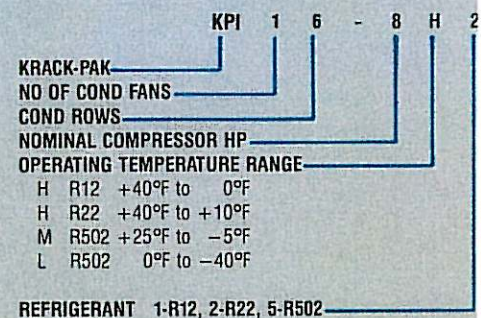

COMPRESSOR AND PHYSICAL DATA

NOMINAL HP	MODEL	COMPRESSOR DATA				SYSTEM AMPACITY 3 PHASE 60 HZ		RECEIVER DATA		CONDENSER FLOODING CHARGE	SYSTEM CONNECTIONS		TOTAL OPERATING WEIGHT LBS
		230-3-60		460-3-60		208-230	440-480	DIA x L INCHES	CAPACITY LBS		SUCTION ODS	LIQUID ODS	
		RLA	LRA	RLA	LRA								
2	ERJ-0200	6.3	46.0	3.4	23.0	10.2	5.4	6 ⁵ / ₈ x 38	41	6	7 ⁷ / ₈	1/2	675
3	NRB-0310	12.9	82.0	6.4	41.0	16.8	8.4	6 ⁵ / ₈ x 38	41	12	1 ¹ / ₈	5/8	725
5	MDA-0500	19.2	115	11.4	53.0	24.0	13.8	10 ³ / ₄ x 36	102	18	1 ³ / ₈	5/8	925
7 ¹ / ₂	3DB-0750	31.5	161	14.3	83.0	36.3	16.7	10 ³ / ₄ x 36	102	27	1 ⁵ / ₈	5/8	975
9	3DF-0900	39.0	215	16.9	106.0	46.4	20.6	10 ³ / ₄ x 36	102	20	1 ⁵ / ₈	7/8	1175
10	3DS-1000	42.0	215	18.6	106.0	49.4	22.3	10 ³ / ₄ x 36	102	20	2 ¹ / ₈	7/8	1200
11	4DA-1000	53.6	233	26.8	115	61.0	30.5	10 ³ / ₄ x 36	102	27	2 ¹ / ₈	7/8	1325
15	4DH-1500	61.4	280	30.7	140	68.8	34.4	10 ³ / ₄ x 36	102	40	2 ¹ / ₈	7/8	1375

NOMINAL HP	MODEL	COMPRESSOR DATA				SYSTEM AMPACITY 3 PHASE 60 HZ		RECEIVER DATA		CONDENSER FLOODING CHARGE	SYSTEM CONNECTIONS		TOTAL OPERATING WEIGHT LBS
		230-3-60		460-3-60		208-230	440-480	DIA x L INCHES	CAPACITY LBS		SUCTION ODS	LIQUID ODS	
		RLA	LRA	RLA	LRA								
2	ERA-0200	6.6	46.0	3.5	23.0	10.5	5.5	6 ⁵ / ₈ x 38	37	5	7 ⁷ / ₈	1/2	675
3	ERF-0310	11.7	82.0	6.4	41.0	15.6	8.4	6 ⁵ / ₈ x 38	37	10	1 ¹ / ₈	5/8	725
5	NRA-0500	19.2	141	9.6	62.5	24.0	12.0	10 ³ / ₄ x 36	93	16	1 ³ / ₈	5/8	925
8	MDA-0750	28.4	175	15.7	75.0	33.2	18.1	10 ³ / ₄ x 36	93	25	1 ⁵ / ₈	5/8	975
10	3DB-1000	43.6	215	20.0	106	51.0	23.7	10 ³ / ₄ x 36	93	25	1 ⁵ / ₈	7/8	1325
15	3DS-1500	59.6	275	29.0	138	67.0	32.7	10 ³ / ₄ x 36	93	36	1 ⁵ / ₈	7/8	1425

NOMINAL HP	MODEL	COMPRESSOR DATA				SYSTEM AMPACITY 3 PHASE 60 HZ		RECEIVER DATA		CONDENSER FLOODING CHARGE	SYSTEM CONNECTIONS		TOTAL OPERATING WEIGHT LBS
		230-3-60		460-3-60		208-230	440-480	DIA x L INCHES	CAPACITY LBS		SUCTION ODS	LIQUID ODS	
		RLA	LRA	RLA	LRA								
2	ERC-0200	6.8	46.0	3.6	23.0	10.7	5.6	6 ⁵ / ₈ x 38	39	6	7 ⁷ / ₈	1/2	675
4	3RA-0310	13.1	82.0	6.6	41.0	17.0	8.6	6 ⁵ / ₈ x 38	39	11	1 ¹ / ₈	5/8	725
5	NRM-0500	24.3	125	12.1	62.5	29.1	14.5	10 ³ / ₄ x 36	97	13	1 ³ / ₈	5/8	925
7 ¹ / ₂	MDA-0750	28.4	175	15.7	75.0	33.2	18.1	10 ³ / ₄ x 36	97	17	1 ⁵ / ₈	5/8	975
10	3DB-1000	43.6	215	20.0	106	51.0	23.7	10 ³ / ₄ x 36	97	20	1 ⁵ / ₈	7/8	1325
15	3DS-1500	59.6	275	29.0	138	67.0	32.7	10 ³ / ₄ x 36	97	26	2 ¹ / ₈	7/8	1425

NOMINAL HP	MODEL	COMPRESSOR DATA				SYSTEM AMPACITY 3 PHASE 60 HZ		RECEIVER DATA		CONDENSER FLOODING CHARGE	SYSTEM CONNECTIONS		TOTAL OPERATING WEIGHT LBS
		230-3-60		460-3-60		208-230	440-480	DIA x L INCHES	CAPACITY LBS		SUCTION ODS	LIQUID ODS	
		RLA	LRA	RLA	LRA								
2	EAV-0200	6.6	46.0	3.5	23.0	11.4	6.0	6 ⁵ / ₈ x 38	39	6	7 ⁷ / ₈	1/2	675
3	NRD-0310	14.3	82.0	7.3	41.0	19.1	9.8	6 ⁵ / ₈ x 38	39	11	1 ¹ / ₈	5/8	725
5	MDA-0600	25.0	150	11.8	53.0	30.7	14.7	10 ³ / ₄ x 36	97	13	1 ³ / ₈	5/8	875
6	3DA-0600	26.5	150	12.0	77.0	32.2	14.9	10 ³ / ₄ x 36	97	13	1 ⁵ / ₈	5/8	875
7	3DB-0750	31.5	161	14.3	83	37.2	17.2	10 ³ / ₄ x 36	97	17	1 ⁵ / ₈	5/8	925
8	3DF-0900	39.0	215	16.9	106	44.7	19.8	10 ³ / ₄ x 36	97	25	1 ⁵ / ₈	5/8	975
9	3DS-1000	42.0	215	18.6	106	50.3	22.8	10 ³ / ₄ x 36	97	20	2 ¹ / ₈	5/8	1175
10	4DA-1000	53.6	240	26.8	120	61.9	31.0	10 ³ / ₄ x 36	97	20	2 ¹ / ₈	5/8	1175
15	4DL-1500	60.0	278	30.0	140	68.3	34.2	10 ³ / ₄ x 36	97	26	2 ¹ / ₈	7/8	1325
20	4DT-2200	71.4	374	35.7	197	79.7	39.9	10 ³ / ₄ x 36	97	38	2 ¹ / ₈	7/8	1350

CAPACITY DATA

R12 HIGH TEMPERATURE

BTUH AT 95°F/35°C AMBIENT								
KPI MODEL	FIG NO.	NOMINAL HP	40°F	30°F	25°F	20°F	10°F	0°F
			4.4°C	-1.1°C	-3.9°C	-6.7°C	-12.2°C	-17.8°C
12L-2H1	1	2	21,000	18,000	16,000	13,000	11,000	8,000
14L-3H1	1	3	32,000	26,000	23,000	20,000	16,000	12,000
14-5H1	2	5	60,000	50,000	47,000	41,000	34,000	27,000
16-8H1	2	8	83,000	71,000	64,000	56,000	47,000	39,000
24-9H1	3	9	101,000	85,000	78,000	70,000	57,000	46,000
24-10H1	3	10	107,000	91,000	83,000	75,000	61,000	49,000
24-11H1	3	11	128,000	105,000	98,000	89,000	73,000	59,000
26-15H1	3	15	160,000	134,000	123,000	111,000	90,000	70,000

R22 HIGH TEMPERATURE

BTUH AT 95°F/35°C AMBIENT								
KPI MODEL	FIG NO.	NOMINAL HP	40°F	30°F	25°F	20°F	10°F	0°F
			4.4°C	-1.1°C	-3.9°C	-6.7°C	-12.2°C	-17.8°C
12L-2H2	1	2	22,000	18,000	15,000	13,000	9,000	—
14L-3H2	1	3	34,000	29,000	25,000	22,000	16,000	—
14-5H2	2	5	64,000	55,000	48,000	43,000	35,000	—
16-8H2	2	8	98,000	77,000	68,000	63,000	49,000	—
24-10H2	3	10	132,000	107,000	98,000	89,000	71,000	—
26-15H2	3	15	177,000	147,000	135,000	121,000	98,000	—

R502 MEDIUM TEMPERATURE

BTUH AT 95°F/35°C AMBIENT								
KPI MODEL	FIG NO.	NOMINAL HP	25°F	20°F	15°F	10°F	0°F	-5°F
			-3.9°C	-6.7°C	-9.4°C	-12.2°C	-17.8°C	-20.6°C
12L-2M5	1	2	19,000	17,000	15,000	14,000	11,000	10,000
14L-3M5	1	4	32,000	29,000	26,000	24,000	19,000	16,000
14-5M5	2	5	58,000	51,000	45,000	39,000	30,000	28,000
14-8M5	2	8	74,000	66,000	59,000	52,000	40,000	32,000
24-10M5	3	10	100,000	94,000	87,000	80,000	65,000	58,000
24-15M5	3	15	130,000	119,000	112,000	102,000	84,000	76,000

R502 LOW TEMPERATURE

BTUH AT 95°F/35°C AMBIENT								
KPI MODEL	FIG NO.	NOMINAL HP	0°F	-10°F	-20°F	-25°F	-30°F	-40°F
			-17.8°C	-23.3°C	-28.9°C	-31.7°C	-34.4°C	-40°C
12L-2L5	1	2	13,500	11,000	8,500	7,500	6,500	5,000
14L-3L5	1	3	24,000	19,000	13,000	12,000	10,000	7,500
14-5L5	2	5	39,000	32,000	25,000	23,000	20,000	13,000
14-6L5	2	6	45,000	36,000	29,000	27,000	24,000	18,000
14-7L5	2	7	58,000	47,000	39,000	33,000	29,000	21,000
16-8L5	2	8	67,000	54,000	45,000	39,000	35,000	26,000
24-9L5	3	9	74,000	60,000	50,000	44,000	39,000	29,000
24-10L5	3	10	82,000	68,000	55,000	49,000	42,000	31,000
24-15L5	3	15	101,000	82,000	65,000	58,000	50,000	38,000
26-20L5	3	20	120,000	100,000	81,000	73,000	64,000	49,000

DIMENSIONS

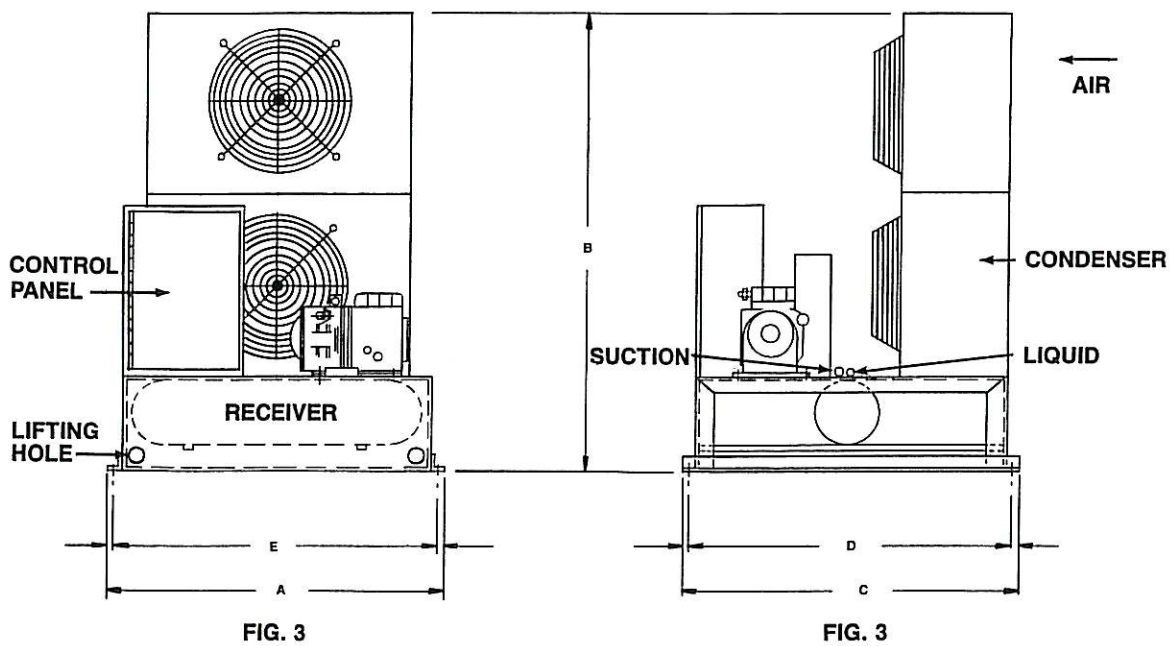
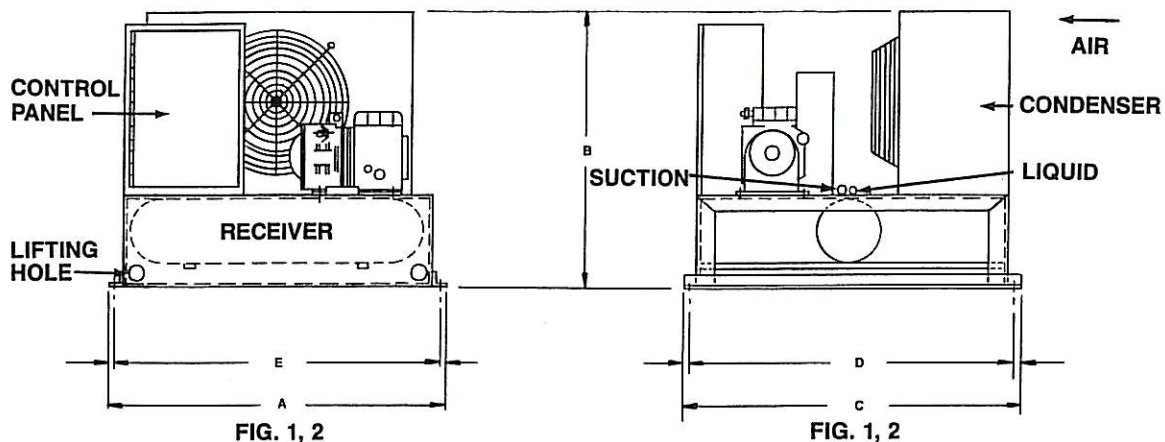

Fig. No.	A	B	C	D	E
1	44	44	44	40	42
2	48	50	49	45	46½
3	48	83	49	45	46½

SEE OPERATING AND
MAINTENANCE MANUAL
FOR RIGGING INSTRUCTIONS

ALL DIMENSIONS IN INCHES. DO NOT USE FOR CONSTRUCTION. USE ONLY CERTIFIED PRINTS.

APPLICATION GUIDELINES

Ground Mounting

The unit should be set on a level concrete pad. Three feet clearance on all sides for service is recommended. Liquid-suction heat exchangers are required at the bottom of the vertical risers. Liquid risers outside the refrigerated space should be insulated. For verticle rise in excess of 30 feet, consult factory.

Liquid Solenoid Valve

Liquid solenoid valves are required at each evaporator. Solenoid valves should not be located at the condensing unit liquid outlet.

Piping

Refrigerant piping should be installed following good piping practices and in accordance with existing piping codes. Care should be taken to avoid hydraulic lock-up and excess vibration. Suction lines must be sized for proper oil return.

Special Applications

Factory approval must be requested for applications using flooded evaporator liquid feeds, ice makers, ice builders, various dairy processing equipment, i.e. which may require oversized receivers, remote start-stop control, and special oil return provisions.

KRACK-PAK MATCHED SYSTEMS CONSIST OF THE FOLLOWING COMPONENTS:

- Condensing Unit
- Unit Cooler
- Defrost Controls
- Thermostatic Expansion Valve
- Liquid Solenoid Valve
- Liquid Suction Heat Exchanger
- Room Thermostat

The diagrams below show typical air defrost and electric defrost field wiring requirements.

AIR DEFROST WITH SINGLE EVAPORATOR

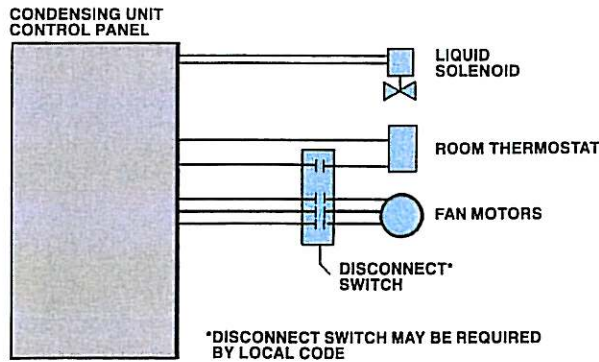

ELECTRIC DEFROST WITH SINGLE EVAPORATOR

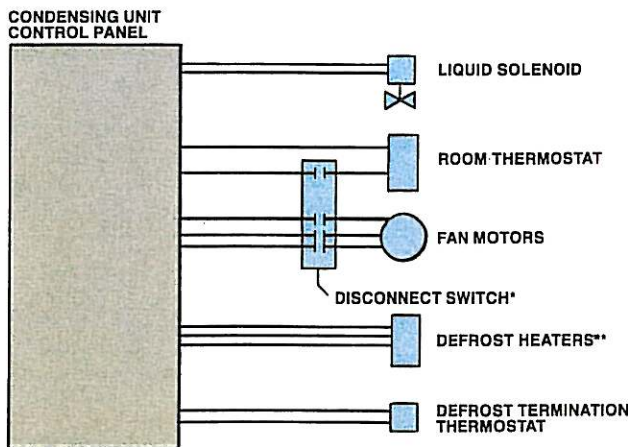

*DISCONNECT SWITCH MAY BE REQUIRED BY ELECTRICAL CODES

**MAXIMUM CURRENT DRAW IS 48 AMPS. ABOVE 48 AMPS CONSULT FACTORY.



Krack Corporation

401 S. Rohlwing Road (Route 53) • Addison, Illinois 60101
Phone: (312) 629-7500 • Telex 72-1435 • Cable: KRACKCOIL
Fax: 312-629-0168