

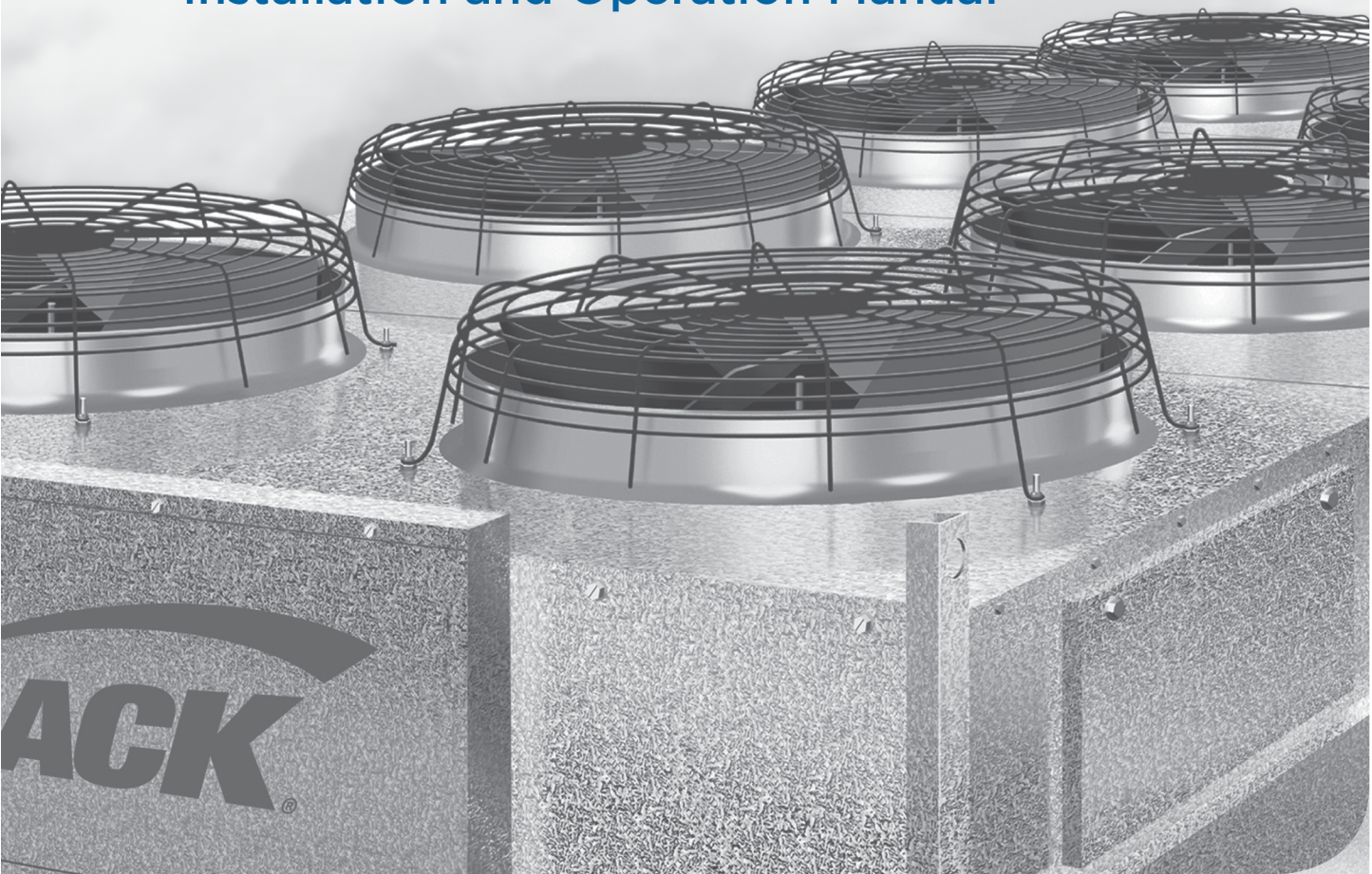

Fluid Cooler Series

AIR-COOLED FLUID COOLING UNITS

Installation and Operation Manual



Part Number: E208134_D

Products that provide lasting solutions.



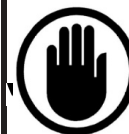

BEFORE YOU BEGIN

Read these instructions completely and carefully.



ANSI Z535.5 DEFINITIONS

-  • **DANGER** – Indicate[s] a hazardous situation which, if not avoided, will result in death or serious injury.
-  • **WARNING** – Indicate[s] a hazardous situation which, if not avoided, could result in death or serious injury.
-  • **CAUTION** – Indicate[s] a hazardous situation which, if not avoided, could result in minor or moderate injury.
- **NOTICE** – Not related to personal injury – Indicates[s] situations, which if not avoided, could result in damage to equipment.

Environmental Concerns

Hussmann recommends responsible handling of refrigerants that contain Chlorine, Fluorine and Carbon (CFCs) and those that contain Hydrogen, Chlorine, Fluorine, and Carbon (HCFCs). Only certified technicians may handle these refrigerants. All technicians must be aware and follow the requirements set forth by the Federal Clean Air Act (Section 608) for any service procedure being performed on this equipment that involves refrigerant. Additionally, some states have other requirements that must be adhered to for responsible management of refrigerants.



This warning does not mean that Hussmann products will cause cancer or reproductive harm, or is in violation of any product-safety standards or requirements. As clarified by the California State government, Proposition 65 can be considered more of a 'right to know' law than a pure product safety law. When used as designed, Hussmann believes that our products are not harmful. We provide the Proposition 65 warning to stay in compliance with California State law. It is your responsibility to provide accurate Proposition 65 warning labels to your customers when necessary. For more information on Proposition 65, please visit the California State government website.

WARNING

PERSONAL PROTECTION EQUIPMENT (PPE)

Only qualified personnel should install and service this equipment. Personal Protection Equipment (PPE) is required whenever servicing this equipment. Wear safety glasses, gloves, protective boots or shoes, long pants, and a long-sleeve shirt when working with this equipment. Observe all precautions on tags, stickers, labels and literature attached to this equipment.



CAUTION

This manual was written in accordance with originally prescribed equipment that is subject to change. Hussmann reserves the right to change all or part of the equipment for future stores such as, but not limited to, controllers, valves and electrical specifications. It is the installers responsibility to reference the refrigeration drawings supplied for each installation, as directed by the Engineer of Record.

CAUTION

Contractors shall strictly adhere to specifications provided by the Engineer of Record (EOR), as well as US Environmental Protection Agency regulations, OSHA regulations, and all other federal, state and local codes. This work should only be done by qualified, li- censed contractors. There are numerous hazards, not limited to, but including: burns due to high temperatures, high pressures, toxic substances, electrical arcs and shocks, very heavy equipment with specific lift points and structural constraints, possible acid exposure, food and product damage, public safety, noise, and possible environmental damage. Never leave operating compressors unattended during the manual soft-start process. Always power rocker switches off when unattended.

TABLE OF CONTENTS

1	RECEIPT OF EQUIPMENT	4
1.1	INSPECTION	4
1.2	LOSS OF GAS HOLDING CHARGE	4
2	MODELS AND DIMENSIONS	4
2.1	UNIT MODELS	4
2.2	UNIT DIMENSIONS WITH A,C,E,F MOTOR TYPES	5
2.3	UNIT DIMENSIONS WITH K MOTOR – VERTICAL DISCHARGE UNIT	7
2.4	UNIT DIMENSIONS FOR UNITS WITH B MOTOR – VERTICAL DISCHARGE UNIT	10
2.5	UNIT DIMENSIONS WITH A,C,E,F MOTOR TYPES – HORIZONTAL AIR DISCHARGE UNITS	12
2.6	UNIT DIMENSIONS FOR UNITS WITH K MOTOR – HORIZONTAL AIR FLOW UNIT	15
2.7	UNIT DIMENSIONS FOR UNITS WITH B MOTOR – HORIZONTAL AIR FLOW UNIT	18
2.8	UNIT WEIGHTS, INTERNAL VOLUME – UNITS WITH A,C,E,F AND K MOTORS	21
2.9	UNIT WEIGHTS, INTERNAL VOLUME - UNITS WITH B MOTOR	22
3	UNIT LOCATION	23
4	RIGGING	24
5	UNIT ASSEMBLY	26
5.1	LEG ASSEMBLY FOR 30" FAN UNIT	26
5.2	HORIZONTAL AIRFLOW BASE SUPPORT	26
5.3	LEG ASSEMBLY FOR 24" FAN UNITS	27
6	INSTALLATION AND PIPING	28
6.1	MOUNTING THE UNIT.....	28
6.2	INTERCONNECTING PIPING FOR DOUBLE-WIDE UNITS.....	28
6.3	FLUID PIPING	28
6.4	RECOMMENDED FLUIDS AND OILS.....	30
6.5	GLYCOL SLUDGE PREVENTION	31
6.6	RECOMMENDED CONNECTION SIZE	31
7	ELECTRICAL	32
7.1	FIELD WIRING	32
7.2	CONTROL PANEL NOMENCLATURE.....	32
7.3	MOTORS WIRING	33
7.4	MOTORS WIRED TO STANDARD FAN CYCLING CONTROL PANEL	33
7.5	CONTROL PANEL WIRING DIAGRAMS	34
7.6	RELAY BOARD WIRING	35
7.7	BACK UP CONTROLLER WIRING	35
7.8	CONTROL SETTINGS	36
7.9	TEMPERATURE SENSOR.....	36
7.10	VFD OPERATION	38
7.11	WIRING OF UNITS WITH VSPEED K MOTOR.....	39
7.12	KB DRIVE SPECIAL SETTING.....	41
7.13	ELECTRICAL MOTOR FLA DATA	42
7.14	FAN MOTOR COMBINATION (KW).....	42
7.15	ELECTRICAL MOTOR DATA AT 50 HZ.....	42
8	INSPECTION AND CLEANING	43
8.1	PRE-STARTUP AND OPERATION INSPECTION	43
8.2	CLEANING	43
8.3	PREVENTIVE MAINTENANCE.....	43
9	REPLACEMENT PARTS LIST	44

TABLES

Table 1 UNIT DIMENSIONS WITH A,C,E,F, MOTORS STD 22" LEGS 6
Table 2 UNIT HEIGHT AND NUMBER OF LEGS WITH EXTENDED LEGS FOR A,C,E,F MOTORS 7
Table 3 UNIT DIMENSIONS WITH K MOTORS STD 22" LEGS 9
Table 4 UNIT HEIGHT AND NUMBER OF LEGS WITH EXTENDED LEGS FOR K MOTOR 10
Table 5 UNIT DIMENSIONS WITH B MOTORS 12
Table 6 UNIT DIMENSIONS WITH A,C,E,F MOTORS HORIZONTAL AIR DISCHARGE 15
Table 7 UNIT DIMENSIONS WITH K MOTOR HORIZONTAL AIR DISCHARGE 18
Table 8 UNIT DIMENSIONS WITH B MOTOR HORIZONTAL AIR DISCHARGE 20
Table 9 UNIT WEIGHT AND INTERNAL VOLUME WITH A,C,E,F MOTORS 21
Table 10 UNIT WEIGHT AND INTERNAL VOLUME WITH B MOTOR 22
Table 11 FLUID PROPERTIES 31
Table 12 CONTROL PANEL SETTINGS 37
Table 13 FAN MOTOR AMPS 42
Table 14 FAN MOTOR COMBINATION KW 42
Table 15 ELECTRICAL MOTOR DATA AT 60 Hz 42
Table 16 REPLACEMENT PARTS 45

FIGURES

Figure 1 UNIT DIMENSIONS WITH A,C,E,F, MOTORS (VERICALE AIR DISCHARGE UNIT) 5
Figure 2 UNIT DIMENSIONS WITH K MOTORS (VERICALE AIR DISCHARGE UNIT) 7
Figure 3 UNIT DIMENSIONS WITH B MOTORS (VERICALE AIR DISCHARGE UNIT) 10
Figure 4 UNIT DIMENSIONS WITH A,C,E,F, MOTORS (HORIZONTAL AIR DISCHARGE UNIT) 12
Figure 5 UNIT DIMENSIONS WITH K MOTOR (HORIZONTAL AIR DISCHARGE UNIT) 15
Figure 6 UNIT DIMENSIONS WITH B MOTOR (HORIZONTAL AIR DISCHARGE UNIT) 18
Figure 7 LOCATION REQUIRMENTS 23
Figure 8 RIGGING FOR 30" FAN UNITS (A,C,E,F,K MOTORS) 24
Figure 9 RIGGING FOR 24" FAN UNITS (B MOTOR) 25
Figure 10 STANDARD 22" LEG ASSEMBLY 26
Figure 11 STANDARD 42" LEG & BRACING ASSEMBLY (UNITS WITH B MOTOR) 27
Figure 12 UNIT MOUNTING AND PIPING 29
Figure 13 TYPICAL PIPING 30
Figure 14 MOTOR WIRING 33
Figure 15 NUMBERING OF FAN MOTORS FOR IDENTIFICATION 33
Figure 16 FAN CYCLING WIRING DIAGRAMS 34
Figure 17 FAN CYCLING IN PAIRS WIRING DIAGRAMS 34
Figure 18 CONTROL PANEL WIRING DRAWING 34
Figure 19 TYPICAL RELAY BOARD WIRING DRAWING (1 WIDE AND 2 WIDE UNITS) 35
Figure 20 WIRING DRAWING BACKUP CONTROLLER (1 WIDE AND 2 WIDE UNITS) 36
Figure 21 TYPICAL VFD WIRING 38
Figure 22 TYPICAL ONE WIDE UNIT DRAWING WITH K MOTOR 39
Figure 23 TYPICAL TWO WIDE UNIT DRAWING WITH K MOTOR 40
Figure 24 FACTORY INSTALLED JUMPER 41
Figure 25 KB DRIVE MINIMUM AND MAXIMUM SPEED SETTING 41
Figure 26 REPLACEMENT PART LIST 44

1 RECEIPT OF EQUIPMENT

1.1 Inspection

All equipment should be carefully checked for damage or shortages as soon as it is received. Each shipment should be carefully checked against the bill of lading. If any damage or shortage is evident, a notation must be made on the delivery receipt before it is signed, and a claim should then be filed against the freight carrier. **Inspection and claims are the responsibility of the recipient.**

1.2 Loss of gas holding charge

The coil section of each Fluid Cooler unit with ODS connections are leak tested, evacuated to remove moisture, and then shipped with a pressurized nitrogen gas holding charge. Absence of this charge may indicate a leak has developed in transit. The system should not be filled with fluid until it is verified that there is no leak, or the source of the leak is located and repaired if necessary. If the coil section has MPT or flanged connections, the coil is not charged. Once the unit is installed in the system check the coil during the system pressure test.

2 MODELS AND DIMENSIONS

2.1 Unit Models

Units with 24" diameter fans are designated "FA...", while the units with 30" diameter fans are "FE..." All units are designed for vertical air discharge, with horizontal air discharge as an option. Each unit is constructed for the fluid and internal working pressure that is indicated on the unit nameplate. All units contain the UL, cUL, and CSA labels to indicate the unit was manufactured using acceptable practices by the governing bodies.

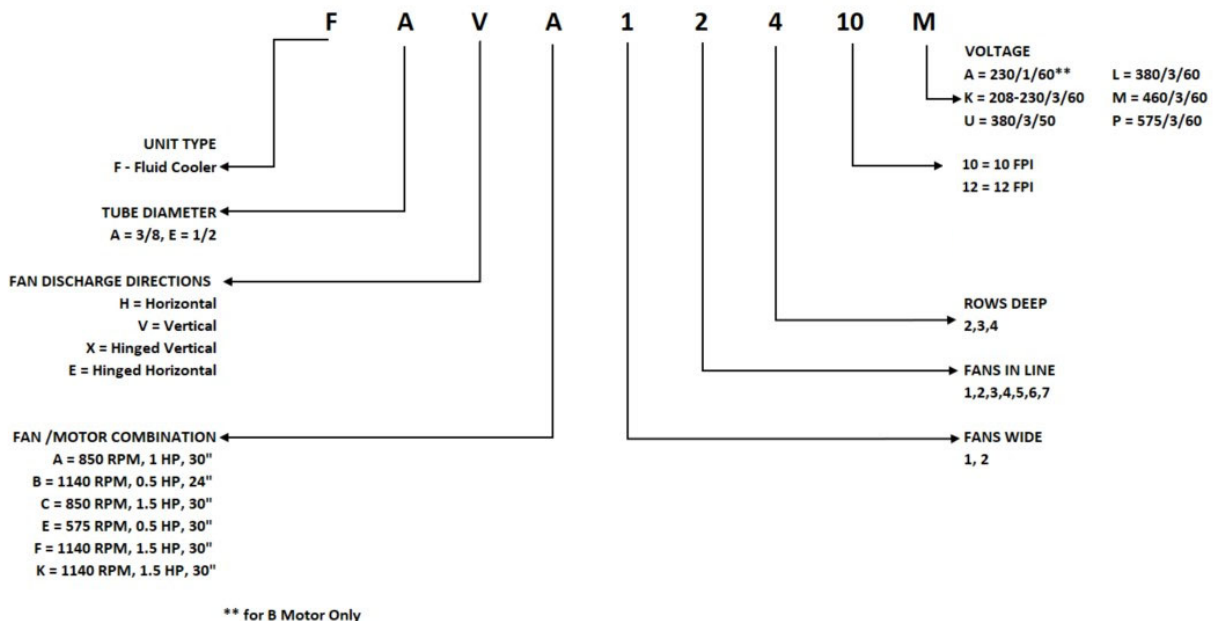

2.2 Unit Dimensions with A,C,E,F Motor Types

Vertical Air Discharge Units

Figure 1 and Table 1 and 2 contain the overall dimensions and support leg bolt hole locations for all of the A, C, E, and F fan units.

Figure 1 Unit Dimensions with A, C, E,F Motor

FRONT VIEW FEV'11

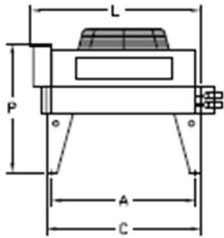

FRONT VIEW FEV'13 & FEV'23

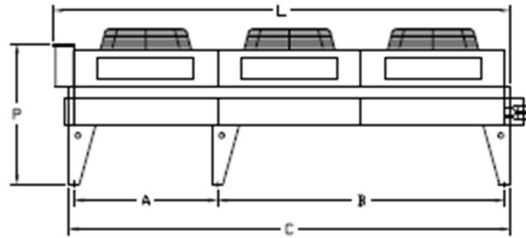

FRONT VIEW FEV'12 & FEV'22

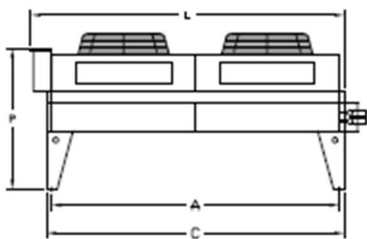

FRONT VIEW FEV'14 & FEV'24

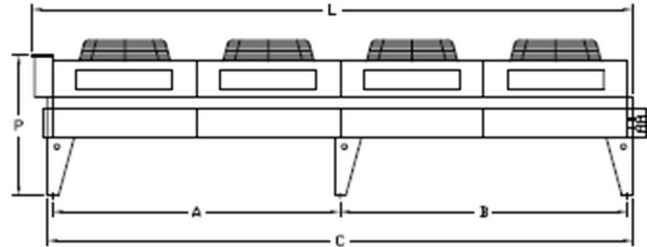

FRONT VIEW FEV'15 & FEV'25

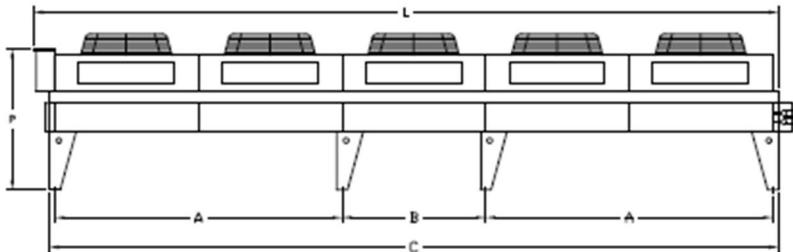

FRONT VIEW FEV'16 & FEV'26

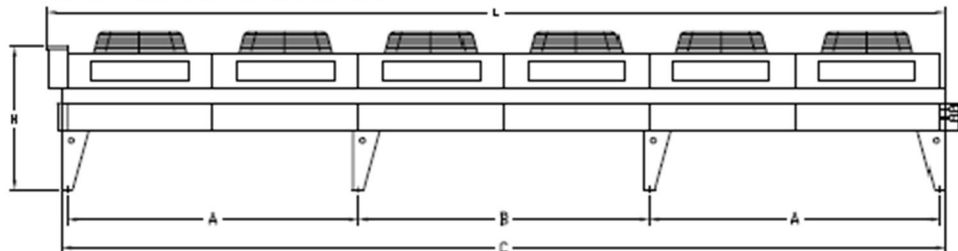

FRONT VIEW FEV'17 & FEV'27

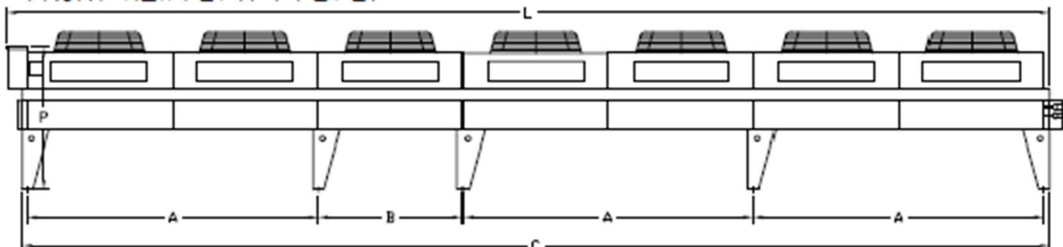

END VIEW FEV*11

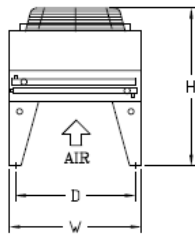

END VIEW
FEV*12, FEV*13, FEV*14,
FEV*15, FEV*16, FEV*17

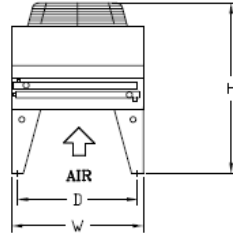

END VIEW
FEV*22, FEV*23, FEV*24

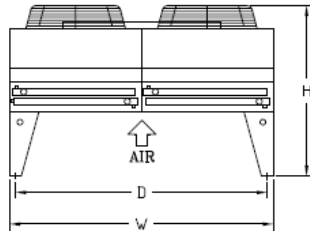

END VIEW
FEV*25, FEV*26, FEV*27

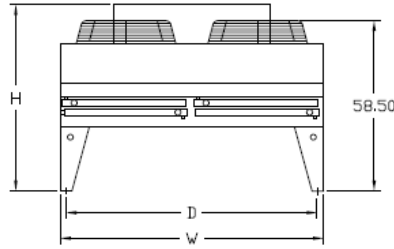

Table 1 – Unit Dimensions with Standard 22” Legs – (A, C, E, F Motors)

MODEL	DIMENSIONS (IN)							
	L	W	H	A	B	C	D	P
FEV*11	63.85	45.25	54.00	54.00	NA	58.00	41.25	48.50
FEV*12	117.85	45.25	58.50	108.00	NA	112.00	41.25	53.00
FEV*13	171.85	45.25	58.50	54.00	108.00	166.00	41.25	53.00
FEV*14	225.85	45.25	58.50	108.00	108.00	220.00	41.25	53.00
FEV*15	279.85	45.25	58.50	108.00	54.00	274.00	41.25	53.00
FEV*16	333.85	45.25	58.50	108.00	108.00	328.00	41.25	53.00
FEV*17	387.85	45.25	58.50	108.00	54.00	382.00	41.25	53.00

MODEL	DIMENSIONS (IN)							
	L	W	H	A	B	C	D	P
FEV*22	117.85	90.55	58.50	108.00	NA	112.00	86.55	53.00
FEV*23	171.85	90.55	58.50	54.00	108.00	166.00	86.55	53.00
FEV*24	225.85	90.55	58.50	108.00	108.00	220.00	86.55	53.00
FEV*25	279.85	90.55	64.00	108.00	54.00	274.00	86.55	53.00
FEV*26	333.85	90.55	64.00	108.00	108.00	328.00	86.55	53.00
FEV*27	387.85	90.55	64.00	108.00	54.00	382.00	86.55	53.00

Units with Optional Legs (Extended 30", 36", 42", 48", or 60" legs) –

Table 2 – Unit Height and Number of Legs with Extended Legs (A, C,E,F Motors)

LEG Ht.	FEV*11		FEV*12		FEV*13		FEV*14		FEV*15		FEV*16		FEV*17	
	Ht.	NO OF LEGS	Ht.	NO OF LEGS	Ht.	NO OF LEGS	Ht.	NO OF LEGS	Ht.	NO OF LEGS	Ht.	NO OF LEGS	Ht.	NO OF LEGS
30	62	4	66.5	4	66.5	6	66.5	6	66.5	8	66.5	8	66.5	10
36	68	4	72.5	4	72.5	6	72.5	6	72.5	8	72.5	8	72.5	10
42	74	4	78.5	4	78.5	6	78.5	6	78.5	8	78.5	8	78.5	10
48	80	4	84.5	6	84.5	8	84.5	10	84.5	12	84.5	14	84.5	16
60	93	4	96.5	6	96.5	8	96.5	10	96.5	12	96.5	14	96.5	16

LEG Ht.	FEV*22		FEV*23		FEV*24		FEV*25		FEV*26		FEV*27	
	Ht.	NO OF LEGS	Ht.	NO OF LEGS	Ht.	NO OF LEGS	Ht.	NO OF LEGS	Ht.	NO OF LEGS	Ht.	NO OF LEGS
30	66.5	4	66.5	6	66.5	6	66.5	8	66.5	8	66.5	10
36	72.5	4	72.5	6	72.5	6	72.5	8	72.5	8	72.5	10
42	78.5	4	78.5	6	78.5	6	78.5	8	78.5	8	78.5	10
48	84.5	6	84.5	8	84.5	10	84.5	12	84.5	14	84.5	16
60	96.5	6	96.5	8	96.5	10	96.5	12	96.5	14	96.5	16

2.3 Unit Dimensions with K Motor – Vertical Discharge Unit

Figure 2 and Table 3 and 4 contain the overall dimensions and support leg bolt hole locations for all the K motor units.

Figure 2 Unit Dimensions with K Motor

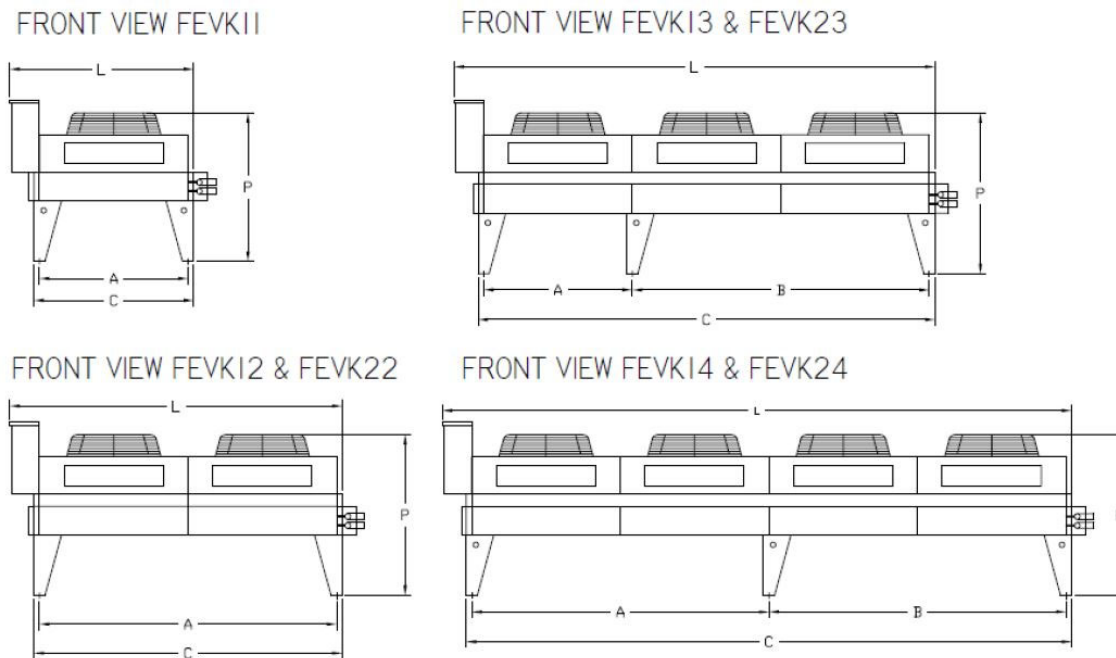

FRONT VIEW FEVK15

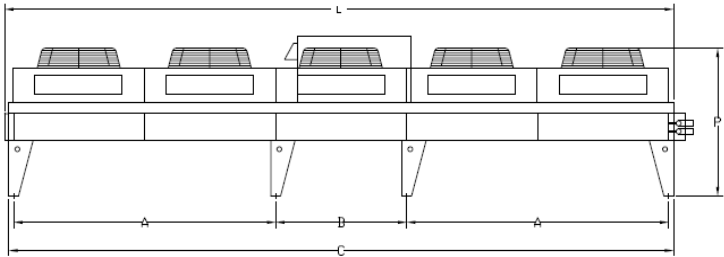

FRONT VIEW FEVK16

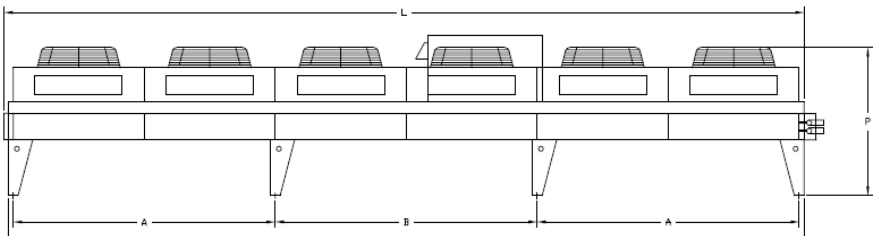

FRONT VIEW FEVK17

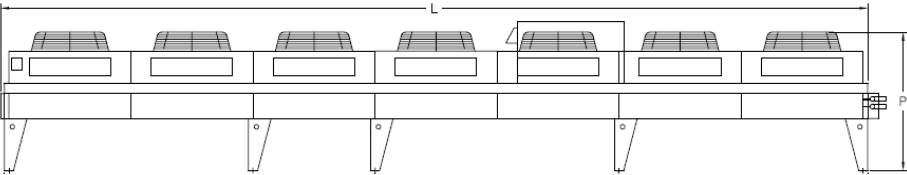

FRONT VIEW FEVK25

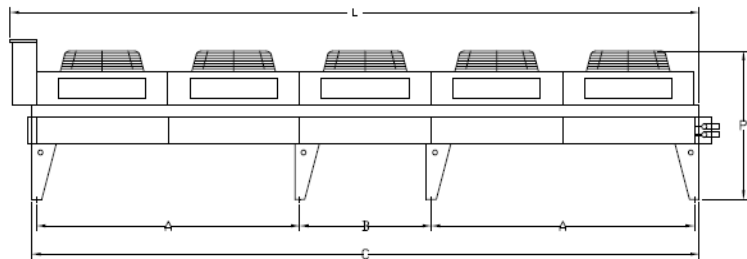

FRONT VIEW FEVK26

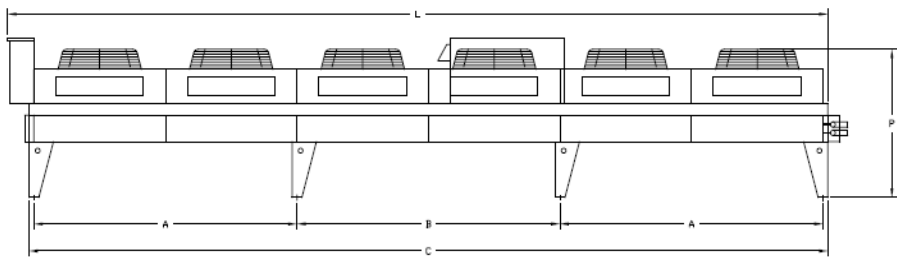

FRONT VIEW FEVK27

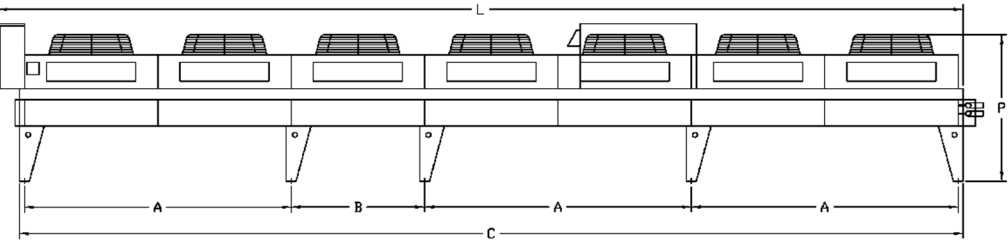

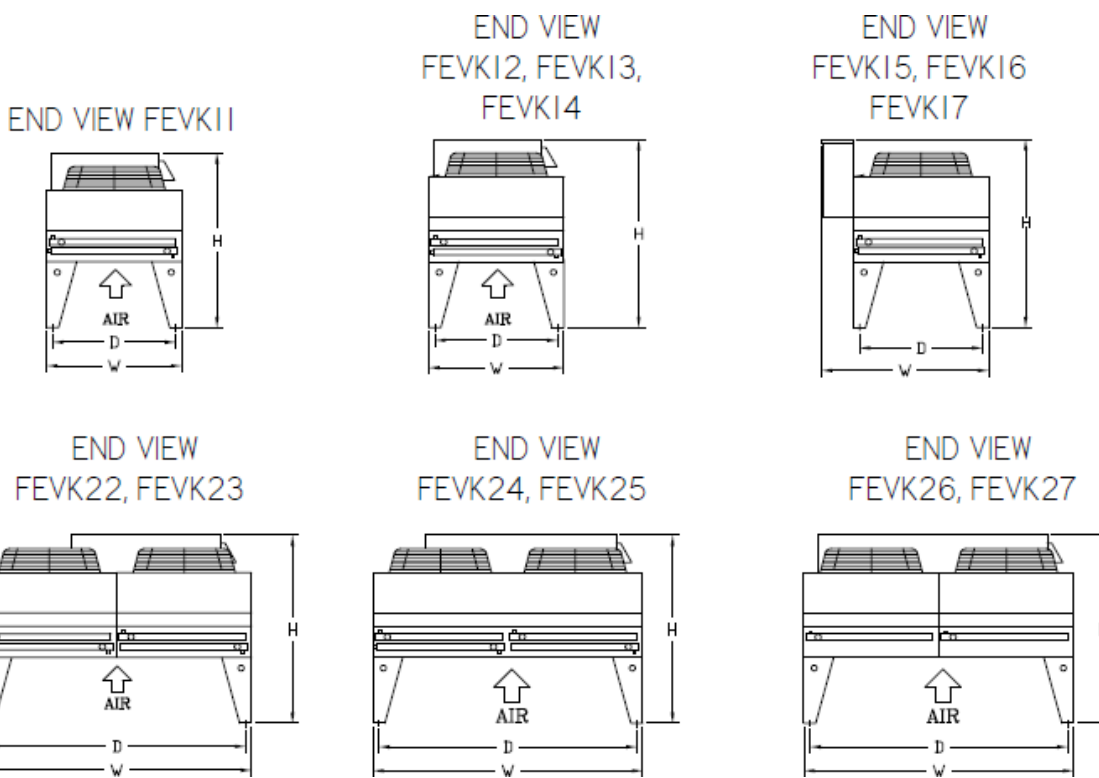

Table 3 – Unit Dimensions with Standard 22" Legs – (K Motors)

MODEL	DIMENSIONS (IN)							
	L	W	H	A	B	C	D	P
FEVK11	66.75	45.25	58.50	54.00	NA	58.00	41.25	54.00
FEVK12	120.75	45.25	63.00	108.00	NA	112.00	41.25	58.50
FEVK13	174.75	45.25	63.00	54.00	108.00	166.00	41.25	58.50
FEVK14	228.75	45.25	63.00	108.00	108.00	220.00	41.25	58.50
FEVK15	274.00	56.00	63.00	108.00	54.00	274.00	41.25	58.50
FEVK16	328.00	56.00	63.00	108.00	108.00	328.00	41.25	58.50
FEVK17	382.00	56.00	63.00	108.00	54.00	382.00	41.25	58.50

MODEL	DIMENSIONS (IN)							
	L	W	H	A	B	C	D	P
FEVK22	120.75	90.55	63.00	108.00	NA	112.00	86.55	58.50
FEVK23	174.75	90.55	63.00	54.00	108.00	166.00	86.55	58.50
FEVK24	228.75	90.55	63.00	108.00	108.00	220.00	86.55	58.50
FEVK25	282.75	90.55	63.00	108.00	54.00	274.00	86.55	58.50
FEVK26	336.75	90.55	63.00	108.00	108.00	328.00	86.55	58.50
FEVK27	390.75	90.55	63.00	108.00	54.00	382.00	86.55	58.50

Units with Optional Legs (Extended 30", 36", 42", 48", or 60" Legs) –

Table 4 – Unit Heights and Number of Legs with Extended Legs – (K Motors)

LEG Ht.	FEVK11		FEVK12		FEVK13		FEVK14		FEVK15		FEVK16		FEVK17	
	Ht.	No. OF LEGS	Ht.	No. OF LEGS	Ht.	No. OF LEGS	Ht.	No. OF LEGS	Ht.	No. OF LEGS	Ht.	No. OF LEGS	Ht.	No. OF LEGS
30	66.5	4	71.0	4	71.0	6	71.0	6	71.0	8	71.0	8	71.0	10
36	72.5	4	77.0	4	77.0	6	77.0	6	77.0	8	77.0	8	77.0	10
42	78.5	4	83.0	4	83.0	6	83.0	6	83.0	8	83.0	8	83.0	10
48	84.5	4	89.0	6	89.0	8	89.0	10	89.0	12	89.0	14	89.0	16
60	96.5	4	101.0	6	101.0	8	101.0	10	101.0	12	101.0	14	101.0	16

LEG Ht.	FEVK22		FEVK23		FEVK24		FEVK25		FEVK26		FEVK27	
	Ht.	No. OF LEGS	Ht.	No. OF LEGS	Ht.	No. OF LEGS	Ht.	No. OF LEGS	Ht.	No. OF LEGS	Ht.	No. OF LEGS
30	71.0	4	71.0	6	71.0	6	71.0	8	71.0	8	71.0	10
36	77.0	4	77.0	6	77.0	6	77.0	8	77.0	8	77.0	10
42	83.0	4	83.0	6	83.0	6	83.0	8	83.0	8	83.0	10
48	89.0	6	89.0	8	89.0	10	89.0	12	89.0	14	89.0	16
60	101.0	6	101.0	8	101.0	10	101.0	12	101.0	14	101.0	16

2.4 Unit Dimensions for Units with B Motor – Vertical Discharge Unit

Figure 3 and Table 5 overall dimensions and support leg bolt hole locations for all the B Motor units.

Figure 3 Unit Dimensions with B Motor

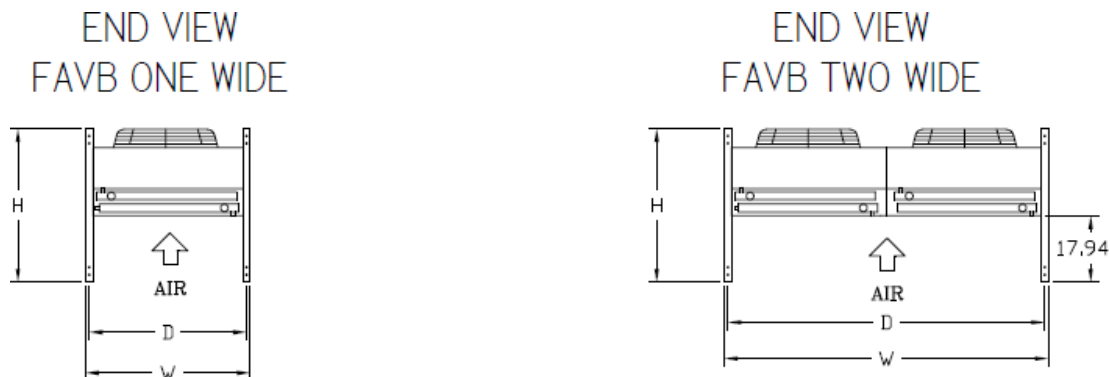

FRONT VIEW
FAVB11 & FAVB21

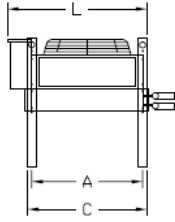

FRONT VIEW
FAVB12 & FAVB22

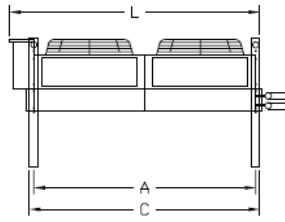

FRONT VIEW
FAVB13 & FAVB23

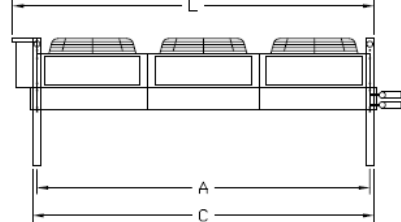

FRONT VIEW
FAVB14 & FAVB24

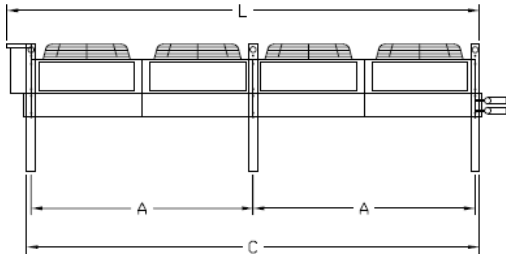

FRONT VIEW
FAVB15 & FAVB25

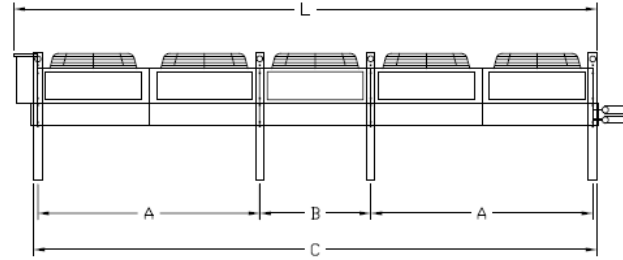

FRONT VIEW
FAVB16 & FAVB26

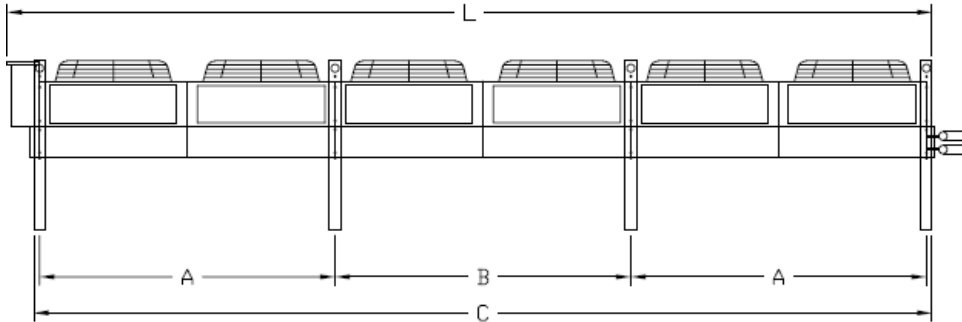

FRONT VIEW
FAVB17 & FAVB27

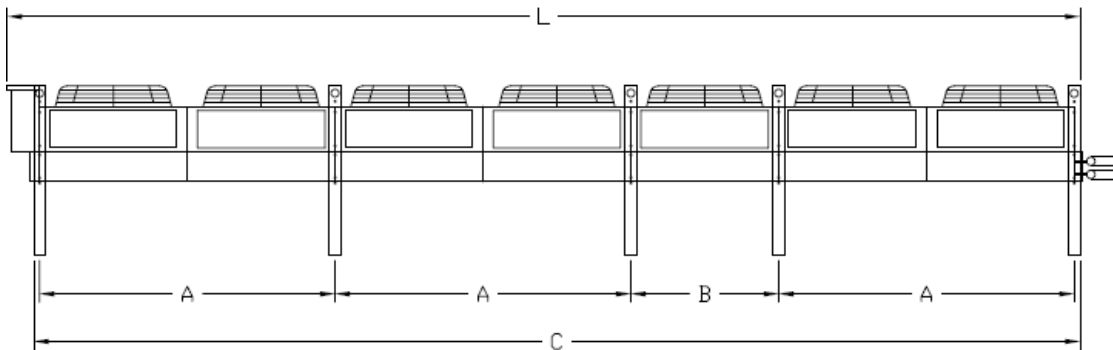

Table 5 – Unit Dimensions with B Motor

MODEL	DIMENSIONS (IN)						
	L	W	H	A	B	C	D
FAVB11	45.22	44.55	41.44	36.00	NA	38.75	42.55
FAVB12	81.22	44.55	41.44	72.00	NA	74.75	42.55
FAVB13	117.22	44.55	41.44	108.00	NA	110.75	42.55
FAVB14	153.22	44.55	41.44	72.00	NA	146.75	42.55
FAVB15	189.22	44.55	41.44	72.00	36.00	182.75	42.55
FAVB16	225.22	44.55	41.44	72.00	NA	218.75	42.55
FAVB17	261.22	44.55	41.44	72.00	36.00	254.75	42.55

MODEL	DIMENSIONS (IN)						
	L	W	H	A	B	C	D
FAVB22	81.22	87.62	41.44	72.00	NA	74.75	85.62
FAVB23	117.22	87.62	41.44	108.00	NA	110.75	85.62
FAVB24	153.22	87.62	41.44	72.00	NA	146.75	85.62
FAVB25	189.22	87.62	41.44	72.00	36.00	182.75	85.62
FAVB26	225.22	87.62	41.44	72.00	NA	218.75	85.62
FAVB27	261.22	87.62	41.44	72.00	36.00	254.75	85.62

2.5 Unit Dimensions with A,C,E,F Motor Types – Horizontal Air Discharge Units

Figure 4 and Tables 2 and 6 contain the overall dimensions and support leg bolt hole locations for all of the A,C,E and F fan units.

Figure 4 Unit Dimensions with A,C,E,F Motor

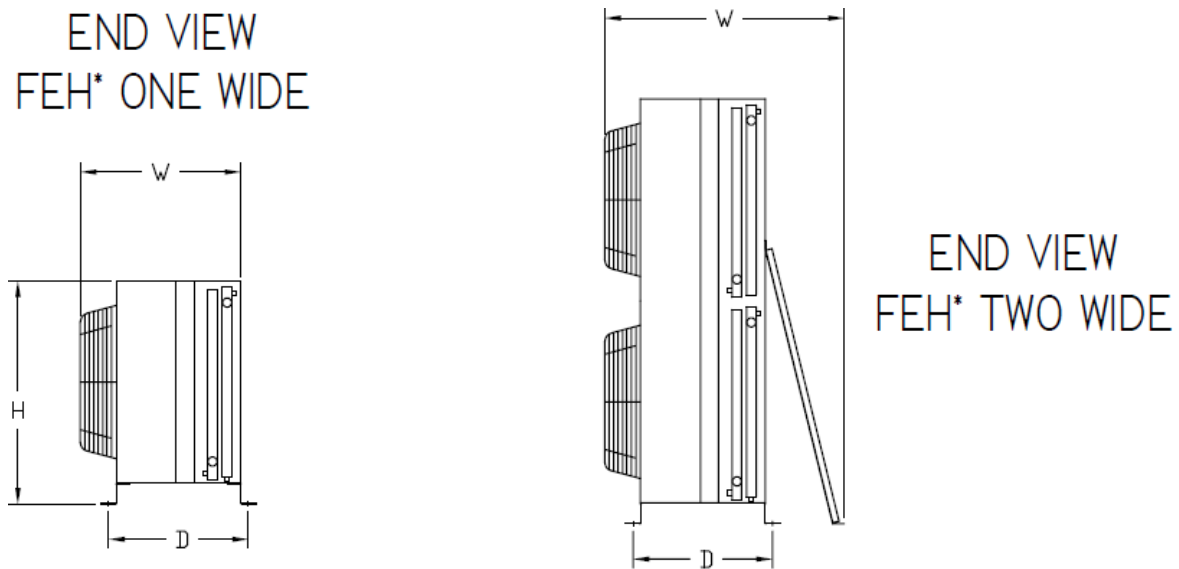

FRONT VIEW FEH*11

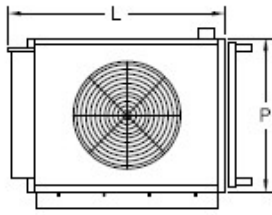

FRONT VIEW FEH*13

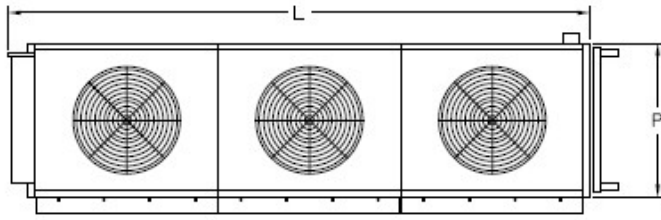

FRONT VIEW FEH*12

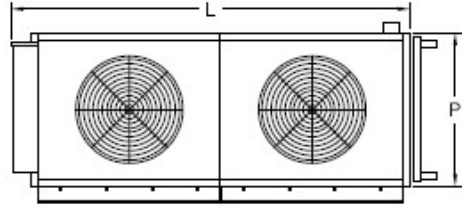

FRONT VIEW FEH*14

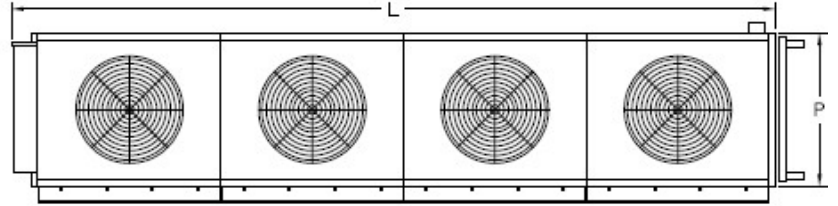

FRONT VIEW FEH*15

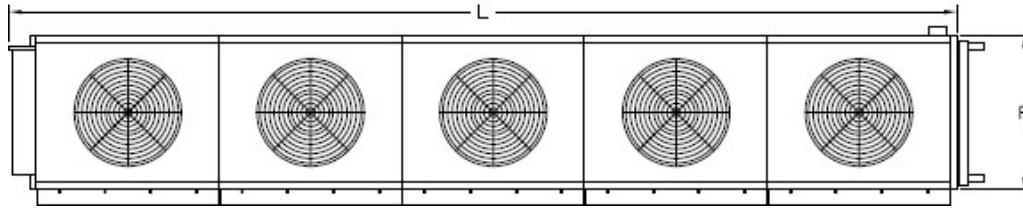

FRONT VIEW FEH*16

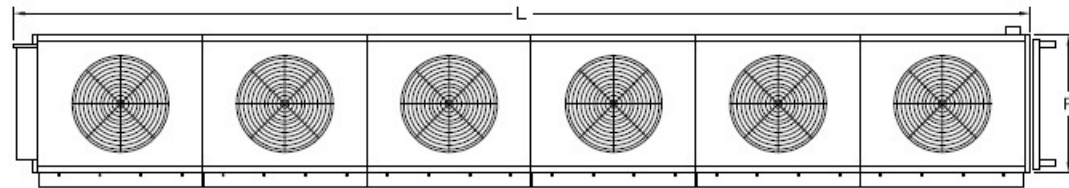

FRONT VIEW FEH*17

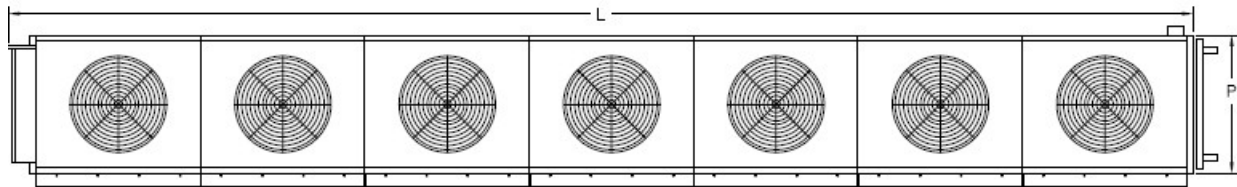

FRONT VIEW FEH*22

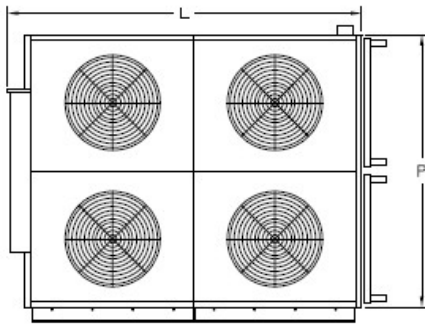

FRONT VIEW FEH*23

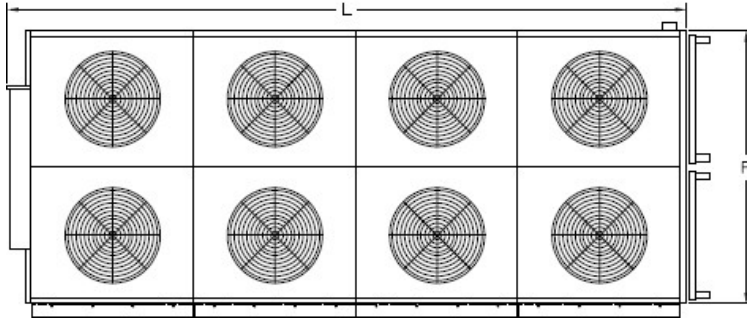
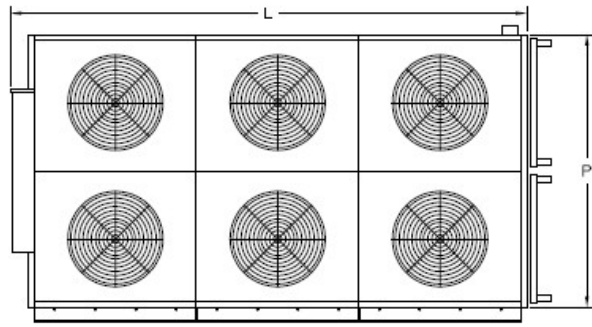

FRONT VIEW FEH*24

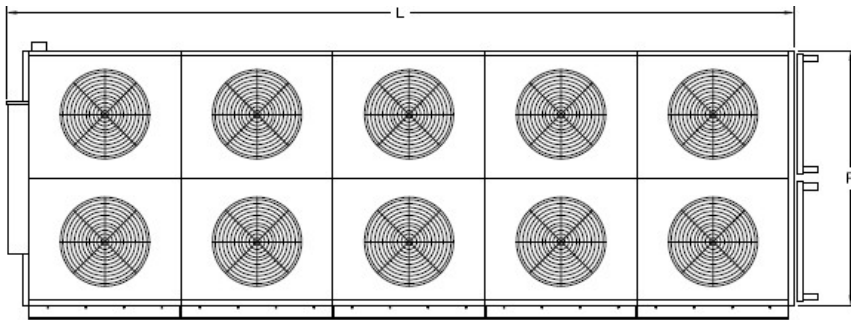

FRONT VIEW FEH*25

FRONT VIEW FEH*26

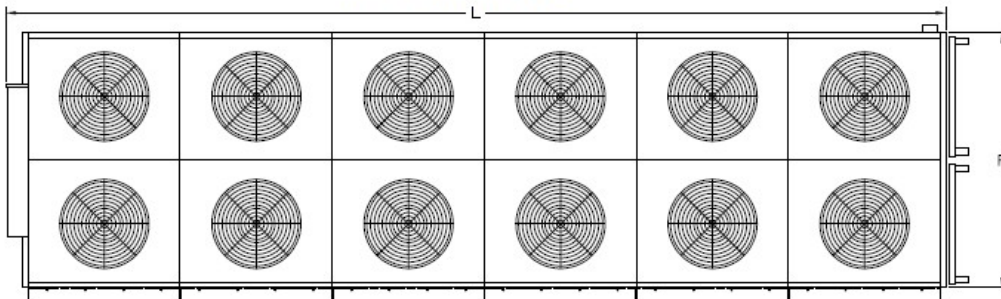

FRONT VIEW FEH*27

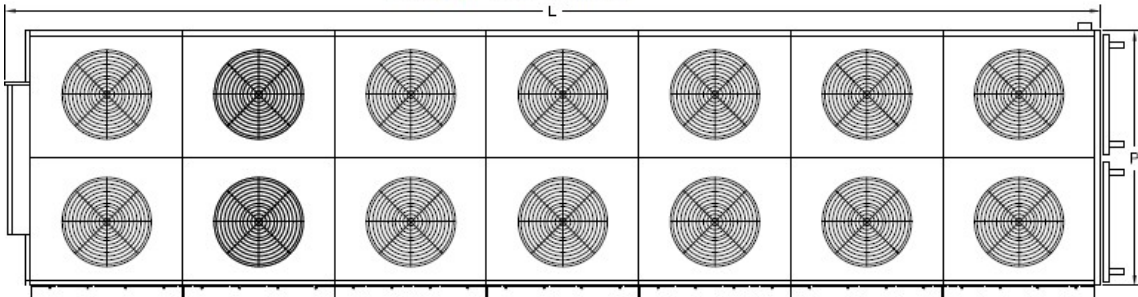

Table 6 – Unit Dimensions – (A,C,E,F Motors) – Horizontal Air Discharge Units

MODEL	DIMENSIONS (IN)				
	L	W	H	D	P
FEH*11	63.85	36.50	49.94	31.75	45.25
FEH*12	117.85	36.50	49.94	31.75	45.25
FEH*13	171.85	36.50	49.94	31.75	45.25
FEH*14	225.85	36.50	49.94	31.75	45.25
FEH*15	279.85	36.50	49.94	31.75	45.25
FEH*16	333.85	36.50	49.94	31.75	45.25
FEH*17	388.88	36.50	49.94	31.75	45.25

MODEL	DIMENSIONS (IN)				
	L	W	H	D	P
FEH*22	117.85	54.18	95.19	31.75	90.50
FEH*23	171.85	54.18	95.19	31.75	90.50
FEH*24	225.85	54.18	95.19	31.75	90.50
FEH*25	279.85	54.18	95.19	31.75	90.50
FEH*26	333.85	54.18	95.19	31.75	90.50
FEH*27	388.88	54.18	95.19	31.75	90.50

2.6 Unit Dimensions for Units with K Motor – Horizontal Air Flow Unit

Figure 5 and Tables 3 and 7 contain the overall dimensions and support leg bolt hole locations for all the K motor units.

Figure 5 Unit Dimensions with K Motor

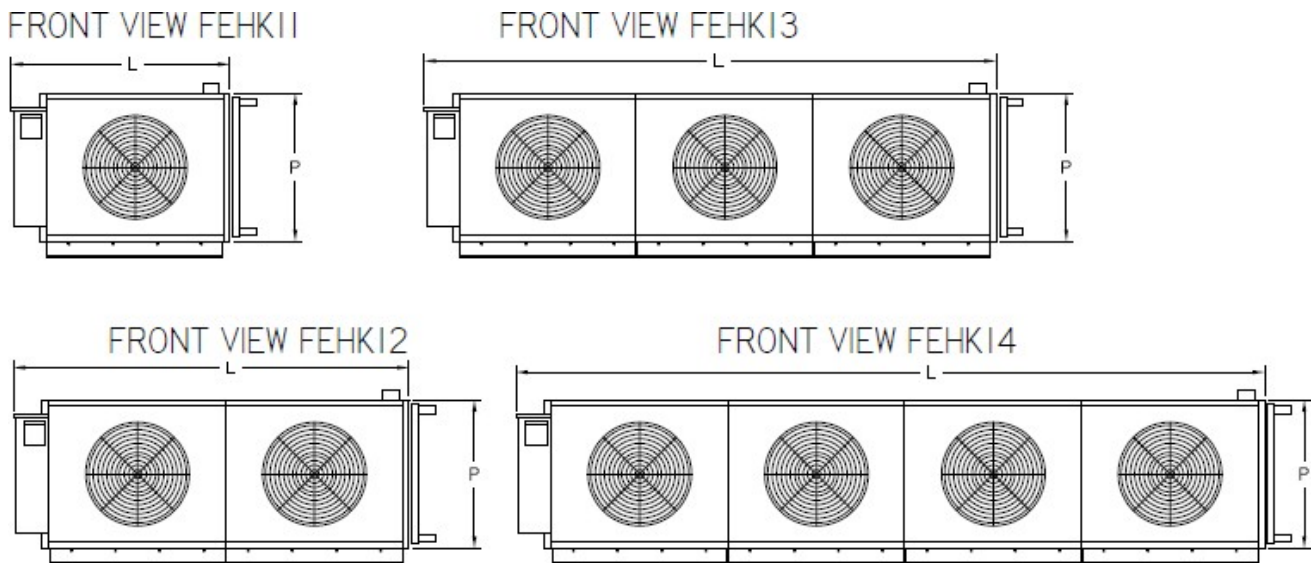

FRONT VIEW FEHK15

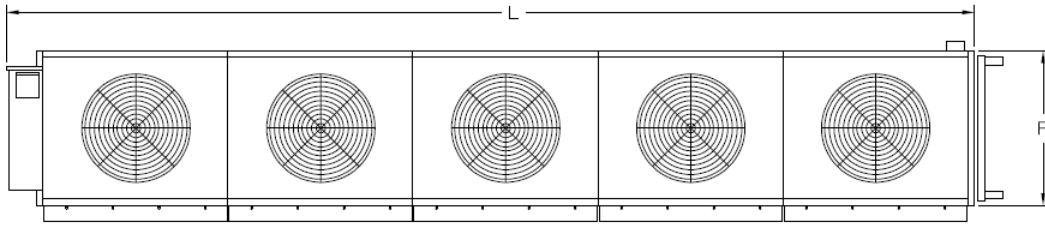

FRONT VIEW FEHK16

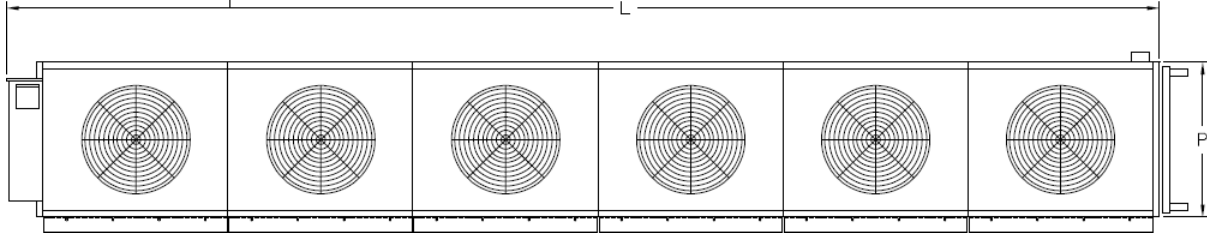

FRONT VIEW FEHK17

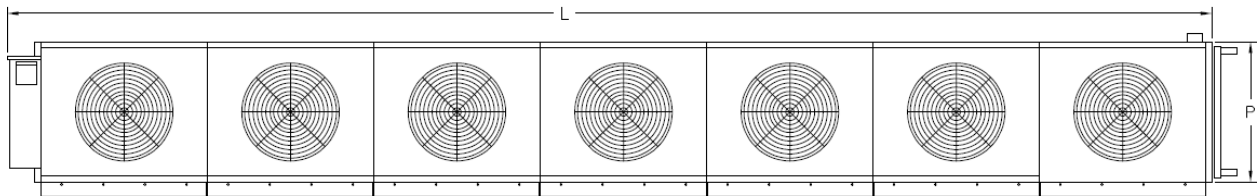

FRONT VIEW FEHK22

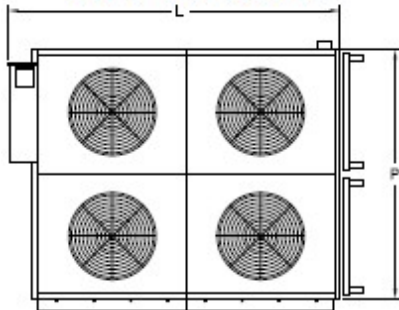

FRONT VIEW FEHK23

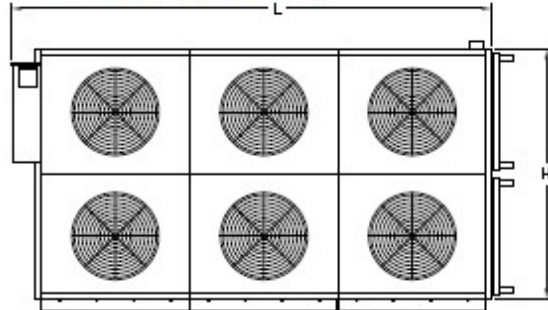

FRONT VIEW FEHK24

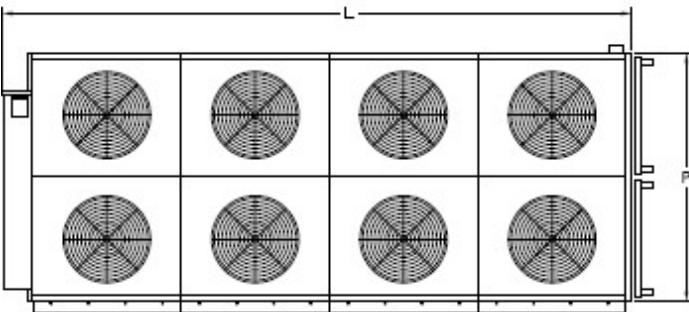

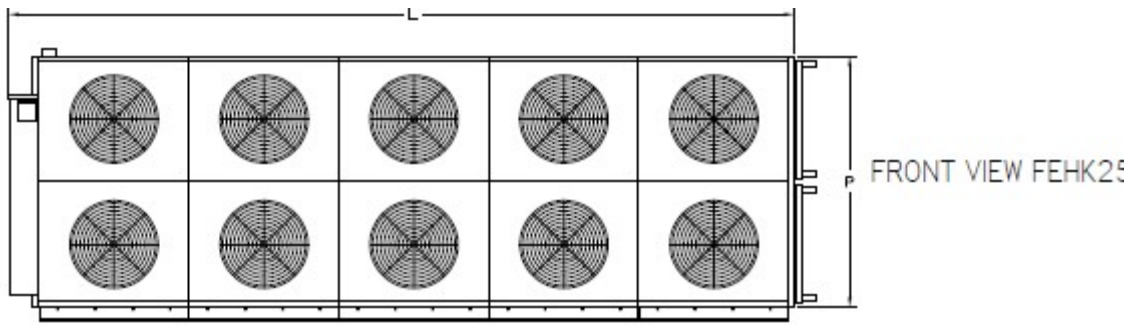

FRONT VIEW FEHK26

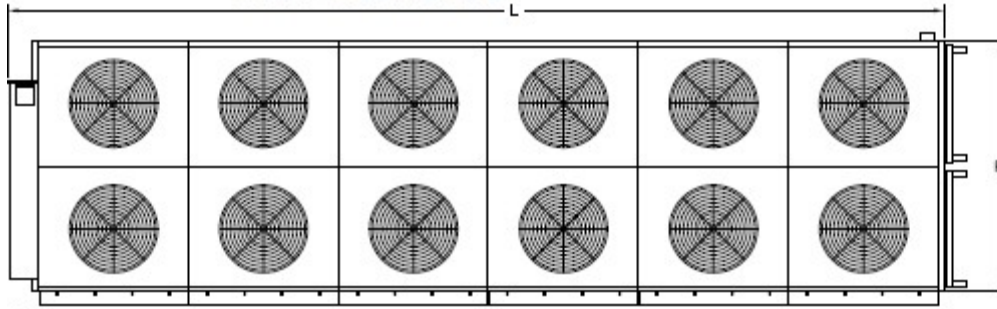

FRONT VIEW FEHK27

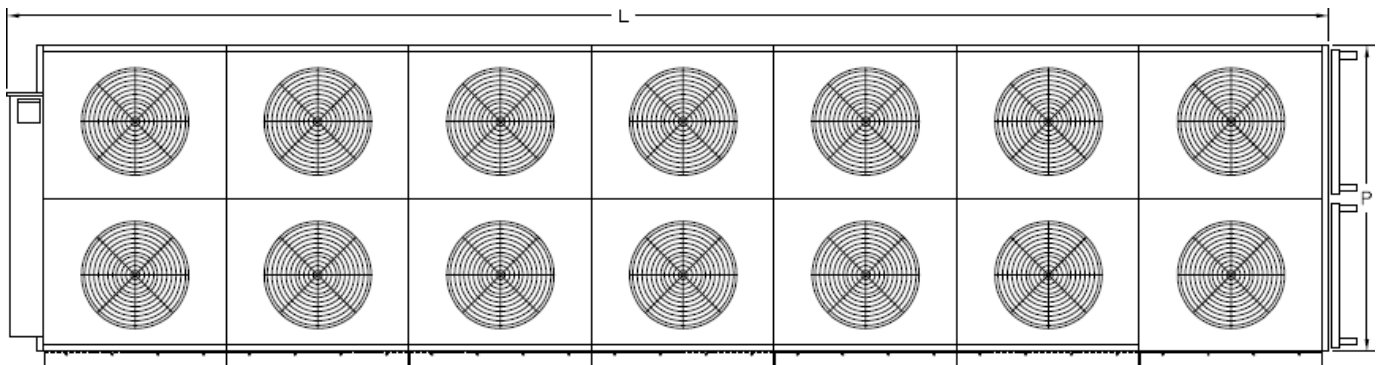

END VIEW
FEHK ONE WIDE

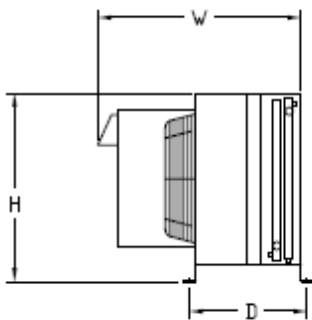

END VIEW
FEHK TWO WIDE

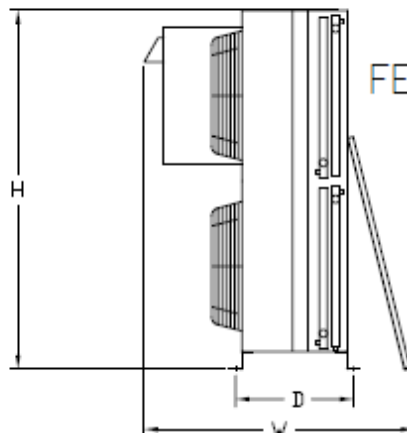

Table 7 – Unit Dimensions with K Motors

MODEL	DIMENSIONS (IN)				
	L	W	H	D	P
FEHK11	66.75	49.90	49.94	31.75	45.25
FEHK12	120.75	53.90	49.94	31.75	45.25
FEHK13	174.75	53.90	49.94	31.75	45.25
FEHK14	228.75	53.90	49.94	31.75	45.25
FEHK15	282.75	53.90	49.94	31.75	45.25
FEHK16	336.75	53.90	49.94	31.75	45.25
FEHK17	390.75	53.90	49.94	31.75	45.25

MODEL	DIMENSIONS (IN)				
	L	W	H	D	P
FEHK22	120.75	71.36	95.19	31.75	90.50
FEHK23	174.75	71.36	95.19	31.75	90.50
FEHK24	228.75	71.36	95.19	31.75	90.50
FEHK25	282.75	71.36	95.19	31.75	90.50
FEHK26	336.75	71.36	95.19	31.75	90.50
FEHK27	390.75	71.36	95.19	31.75	90.50

2.7 Unit Dimensions for Units with B Motor – Horizontal Air Flow Unit

Figure 6 and Tables 5 and 8 contain the overall dimensions and support leg bolt hole locations for all the K motor units.

Figure 6 Unit Dimensions with B Motor

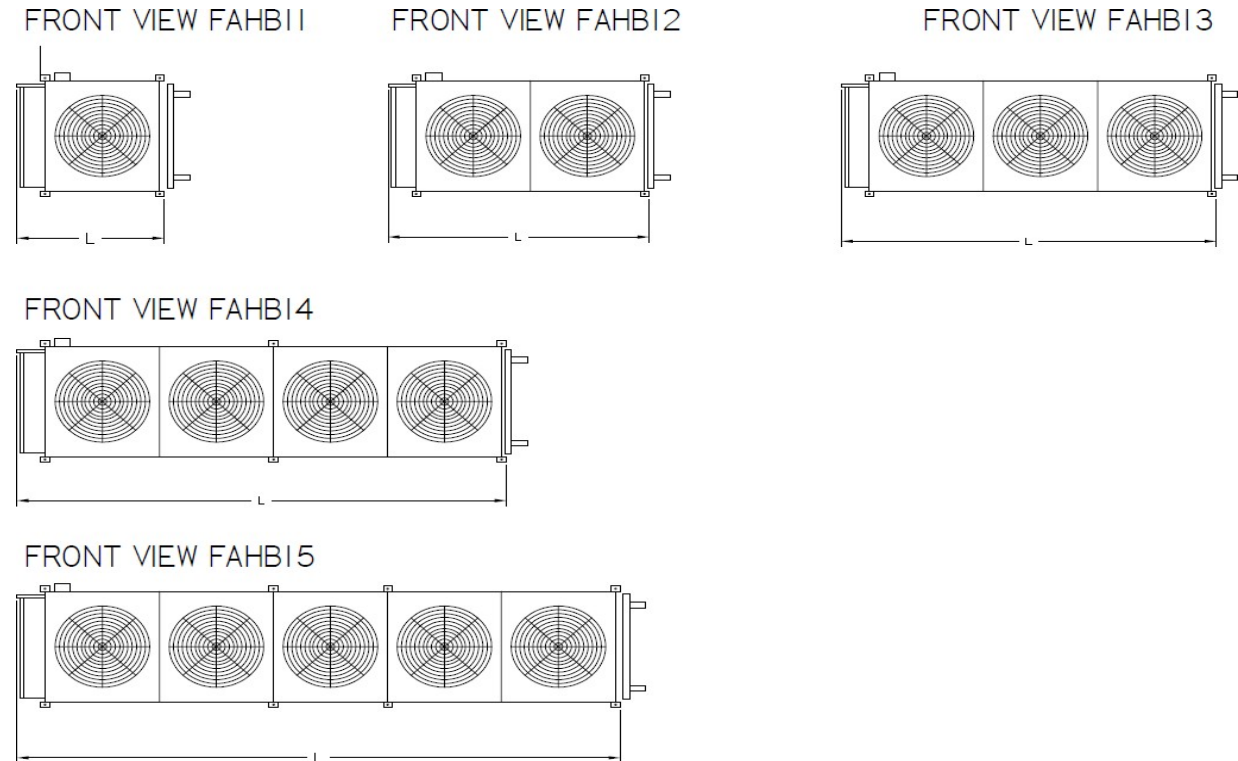

FRONT VIEW FAHB14

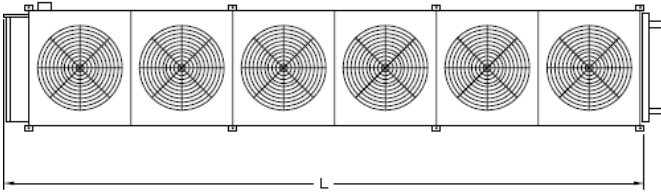

FRONT VIEW FAHB15

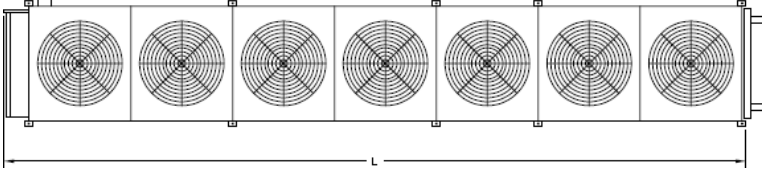

FRONT VIEW FEHB22

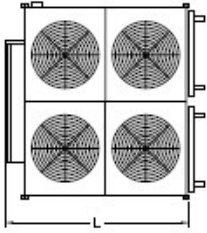

FRONT VIEW FEHB23

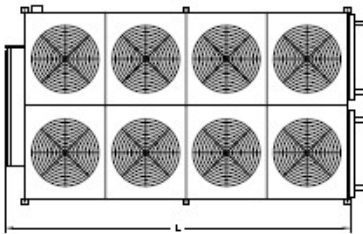
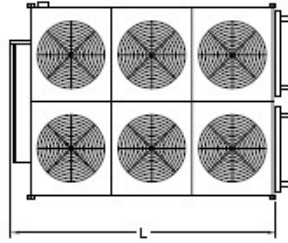

FRONT VIEW FEHB24

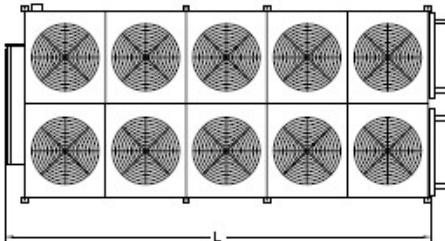

FRONT VIEW FEHB25

FRONT VIEW FEHB26

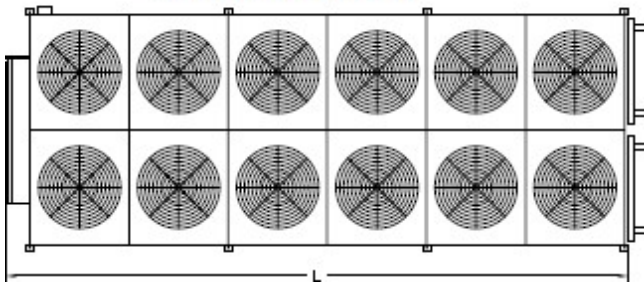

FRONT VIEW FEHB27

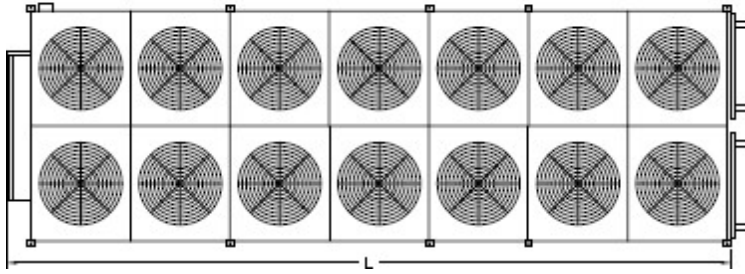

END VIEW
FAHB TWO WIDE

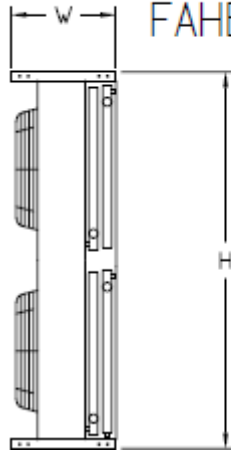

END VIEW
FAHB ONE WIDE

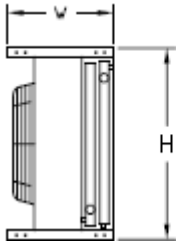

Table 8 – Unit Dimensions with B Motors

MODEL	DIMENSIONS(IN)		
	L	W	H
FAHB11	46.31	24.50	44.50
FAHB12	82.31	24.50	44.50
FAHB13	118.31	24.50	44.50
FAHB14	154.31	24.50	44.50
FAHB15	190.31	24.50	44.50
FAHB16	226.31	24.50	44.50
FAHB17	262.31	24.50	44.50

MODEL	DIMENSIONS (IN)		
	L	W	H
FAHB22	82.31	24.50	87.62
FAHB23	118.31	24.50	87.62
FAHB24	154.31	24.50	87.62
FAHB25	190.31	24.50	87.62
FAHB26	226.31	24.50	87.62
FAHB27	262.31	24.50	87.62

2.8 Unit Weights, Internal Volume – Units with A,C,E,F and K Motors

The following table contains approximate unit shipping weights and internal volumes for the 30" fan units.

Table below shows the values from vertical air flow models. Values remain the same for horizontal air flow models.

Table 9 – Models with A, C, E, F, and K Motors

MODEL	SHIP WEIGHT (LBS)	INTERNAL VOLUME (GAL)
FEV*11208	437	3.7
FEV*11210	439	3.7
FEV*11212	444	3.7
FEV*11308	466	5.3
FEV*11310	469	5.3
FEV*11312	478	5.3
FEV*11408	495	6.9
FEV*11410	499	6.9
FEV*11412	508	6.9
FEV*12208	718	6.6
FEV*12210	721	6.6
FEV*12212	729	6.6
FEV*12308	773	9.7
FEV*12310	779	9.7
FEV*12312	792	9.7
FEV*12408	830	16.6
FEV*12410	838	16.6
FEV*12412	855	16.6
FEV*13210	1041	9.6
FEV*13212	1060	9.6
FEV*13308	1126	14.1
FEV*13310	1135	14.1
FEV*13312	1153	14.1
FEV*13408	1210	18.7
FEV*13410	1223	18.7
FEV*13412	1247	18.7
FEV*14308	1437	18.6
FEV*14310	1449	18.6
FEV*14312	1474	18.6
FEV*14408	1550	24.6
FEV*14410	1566	24.6
FEV*14412	1599	24.6
FEV*15308	2020	22.9
FEV*15310	2035	22.9
FEV*15312	2066	22.9
FEV*15408	2160	30.5
FEV*15410	2181	30.5
FEV*15412	2222	30.5
FEV*16308	2554	27.4
FEV*16310	2573	27.4
FEV*16312	2610	27.4
FEV*16408	2784	36.4
FEV*16410	2808	36.4
FEV*16412	2858	36.4
FEV*17308	3020	31.9
FEV*17310	3042	31.9
FEV*17312	3088	31.9
FEV*17408	3279	42.3
FEV*17410	3307	42.3
FEV*17412	3366	42.3

MODEL	SHIP WEIGHT (LBS)	INTERNAL VOLUME (GAL)
FEV*22208	1311	12.8
FEV*22210	1320	12.8
FEV*22212	1336	12.8
FEV*22308	1437	19.1
FEV*22310	1425	19.1
FEV*22312	1462	19.1
FEV*22408	1539	25.3
FEV*22410	1555	25.3
FEV*22412	1588	25.3
FEV*23210	1875	18.7
FEV*23212	1912	18.7
FEV*23308	2044	27.9
FEV*23310	2063	27.9
FEV*23312	2100	27.9
FEV*23408	2214	37.1
FEV*23410	2238	37.1
FEV*23412	2287	37.1
FEV*24308	2526	36.7
FEV*24310	2651	36.7
FEV*24312	2700	36.7
FEV*24408	2851	48.8
FEV*24410	2884	48.8
FEV*24412	2950	48.8
FEV*25308	3725	45.6
FEV*25310	3755	45.6
FEV*25312	3817	45.6
FEV*25408	4005	60.7
FEV*25410	4046	60.7
FEV*25412	4129	60.7
FEV*26308	4759	54.6
FEV*26310	4796	54.6
FEV*26312	4870	54.6
FEV*26408	5218	72.5
FEV*26410	5268	72.5
FEV*26412	5366	72.5
FEV*27308	5691	63.6
FEV*27310	5734	63.6
FEV*27312	5826	63.6
FEV*27408	6208	84.3
FEV*27410	6266	84.3
FEV*27412	6382	84.3

2.9 Unit Weights, Internal Volume - Units with B Motor

The following table contains approximate unit shipping weights and internal volumes for the 24" fan units.

Table below shows the values from vertical air flow models, values remains the same for horizontal air flow models.

Table 10 – Models with B Motors

MODEL	SHIP WEIGHT (LBS)	INTERNAL VOLUME (GAL)
FAVB11208	178	1.2
FAVB11210	181	1.2
FAVB11212	184	1.2
FAVB11308	180	1.8
FAVB11310	185	1.8
FAVB11312	190	1.8
FAVB11408	193	2.3
FAVB11410	200	2.3
FAVB11412	207	2.3
FAVB12208	346	2.2
FAVB12210	352	2.2
FAVB12212	358	2.2
FAVB12308	362	3.2
FAVB12310	372	3.2
FAVB12312	382	3.2
FAVB12408	386	5.5
FAVB12410	400	5.5
FAVB12412	413	5.5
FAVB13308	544	4.7
FAVB13310	559	4.7
FAVB13312	574	4.7
FAVB13408	580	6.2
FAVB13410	600	6.2
FAVB13412	620	6.2
FAVB14308	820	6.2
FAVB14310	840	6.2
FAVB14312	860	6.2
FAVB14408	873	8.1
FAVB14410	900	8.1
FAVB14412	927	8.1
FAVB15308	836	7.6
FAVB15310	861	7.6
FAVB15312	886	7.6
FAVB15408	917	10.1
FAVB15410	950	10.1
FAVB15412	983	10.1
FAVB16308	1040	9.1
FAVB16310	1070	9.1
FAVB16312	1100	9.1
FAVB16408	1110	12.0
FAVB16410	1150	12.0
FAVB16412	1190	12.0
FAVB17308	1314	10.6
FAVB17310	1349	10.6
FAVB17312	1384	10.6
FAVB17408	1404	14.0
FAVB17410	1450	14.0
FAVB17412	1497	14.0

MODEL	SHIP WEIGHT (LBS)	INTERNAL VOLUME (GAL)
FAVB22208	642	4.2
FAVB22210	654	4.2
FAVB22212	666	4.2
FAVB22308	845	6.3
FAVB22310	865	6.3
FAVB22312	885	6.3
FAVB22408	895	8.4
FAVB22410	923	8.4
FAVB22412	953	8.4
FAVB23308	1088	9.2
FAVB23310	1118	9.2
FAVB23312	1148	9.2
FAVB23408	1185	12.3
FAVB23410	1225	12.3
FAVB23412	1265	12.3
FAVB24308	1665	12.1
FAVB24310	1705	12.1
FAVB24312	1745	12.1
FAVB24408	1771	16.1
FAVB24410	1825	16.1
FAVB24412	1880	16.1
FAVB25308	1672	15.1
FAVB25310	1722	15.1
FAVB25312	1772	15.1
FAVB25408	1859	20.1
FAVB25410	1925	20.1
FAVB25412	1991	20.1
FAVB26308	2035	18.1
FAVB26310	2095	18.1
FAVB26312	2155	18.1
FAVB26408	2145	24.0
FAVB26410	2225	24.0
FAVB26412	2305	24.0
FAVB27308	2655	21.0
FAVB27310	2725	21.0
FAVB27312	2795	21.0
FAVB27408	2835	27.9
FAVB27410	2925	27.9
FAVB27412	3015	27.9

3 UNIT LOCATION

Fluid Coolers require adequate space to allow unrestricted ambient airflow in to and out of the fan section. Figure 7 gives general rules as to the location of a fluid cooling unit regarding different situations. The distances shown in the sketches should be increased whenever possible. The unit position relative to the prevailing winds should be considered. Note that higher than expected return fluid temperatures will result in poor system operation if the following suggested distances are not used.

To ensure a unit performs as predicted, it should be located away from heated air exhausts, steam vents, or corrosive airflows whether it comes from the user site or from another nearby source. A corrosive atmosphere will require a coil coating.

Unit sound levels should be considered for the unit location. A fluid cooling unit should be located away from sound and vibration sensitive spaces to avoid transmission into those spaces.

FIGURE 7 LOCATION REQUIREMENTS

Walls or Barriers

For proper airflow and access, all sides of the unit should be a minimum of “W” away from any wall or barrier. Enough space should be allowed for all maintenance work. Overhead obstructions are not allowed.

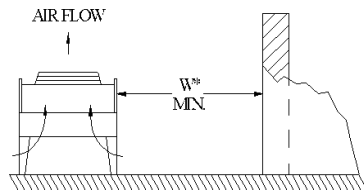

Multiple Units

For units placed side by side, the minimum distance between units is the width of the largest unit. If units are placed end to end, the minimum distance between units is one fan section long.

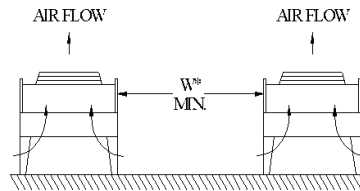

Walls or Barriers for Horizontal Airflow

Units with horizontal airflow should be a minimum of “W” away from any wall or barrier, plus the air discharge should be free flowing away from the unit.

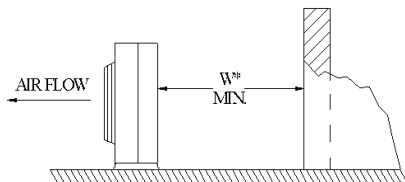

Decorative Fences

Fences must have 50% free area, with 1 foot undercut, a “W” minimum clearance, and must not exceed the top of the unit.

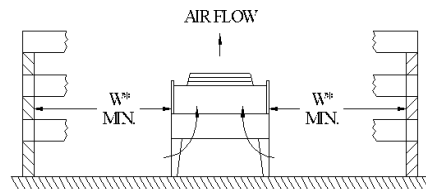

W = Total width of the Fluid Cooling unit – Single or Double wide.

4 RIGGING

Fluid Coolers are designed to be lifted using the leg support channels or the side lifting brackets for larger units. The unit mounting leg assemblies are best attached when the unit is in the flat, fans facing up, and supported by the rigging. Take special care not to bump, hit, or otherwise stress the tubing, headers, or connections during the lifting and positioning of the unit. Under no circumstances should the coil headers or return bends be used in lifting or moving the unit. See Figures 8 and 9 for the designated lifting points and lift methods for all unit sizes plus approximate unit weights.

FIGURE 8 RIGGING AND LIFTING FOR 30" FAN UNITS – UNITS WITH A,C,E,F AND K MOTORS

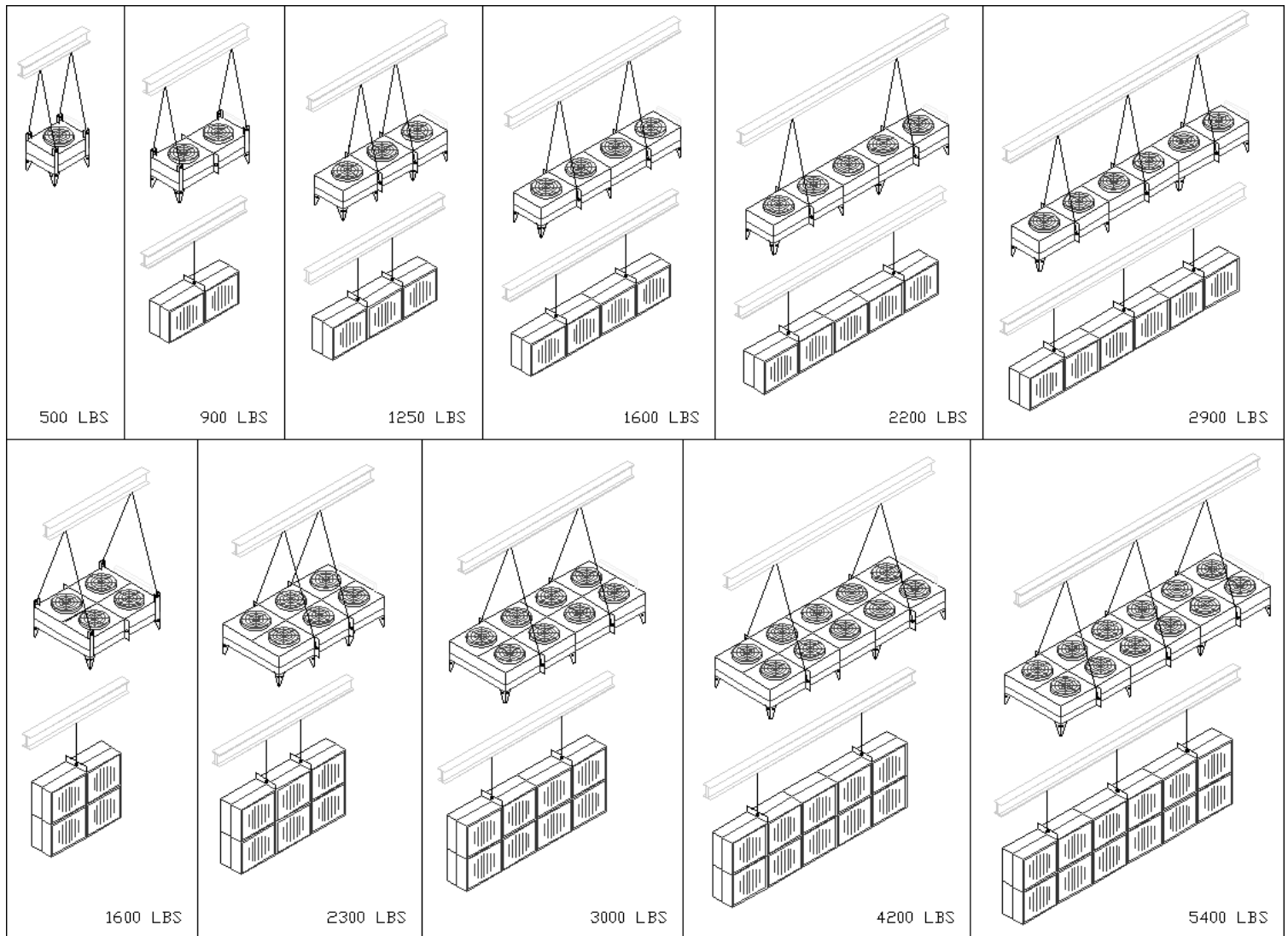

NOTE: STATIONARY LIFTING POINTS AND LIFTING PLATES FACTORY MOUNTED. OUTER SUPPORT LEGS (IF REQUIRED) SHIPPED LOOSE FOR FIELD INSTALLATION BY OTHERS WITH NECESSARY BOLTS, WASHERS AND NUTS INCLUDED, (SEE SECTION 5.1 FOR LEG MOUNTING INSTRUCTIONS). UNDER NO CIRCUMSTANCES SHOULD CONSIDER MANIFOLDS, ELECTRICAL ENCLOSURE(S) OR RETURN BENDS BE USE FOR LIFTING OR MOVING THE UNITS!

FIGURE 9 RIGGING AND LIFTING FOR 24" FAN UNITS – UNITS WITH B MOTOR

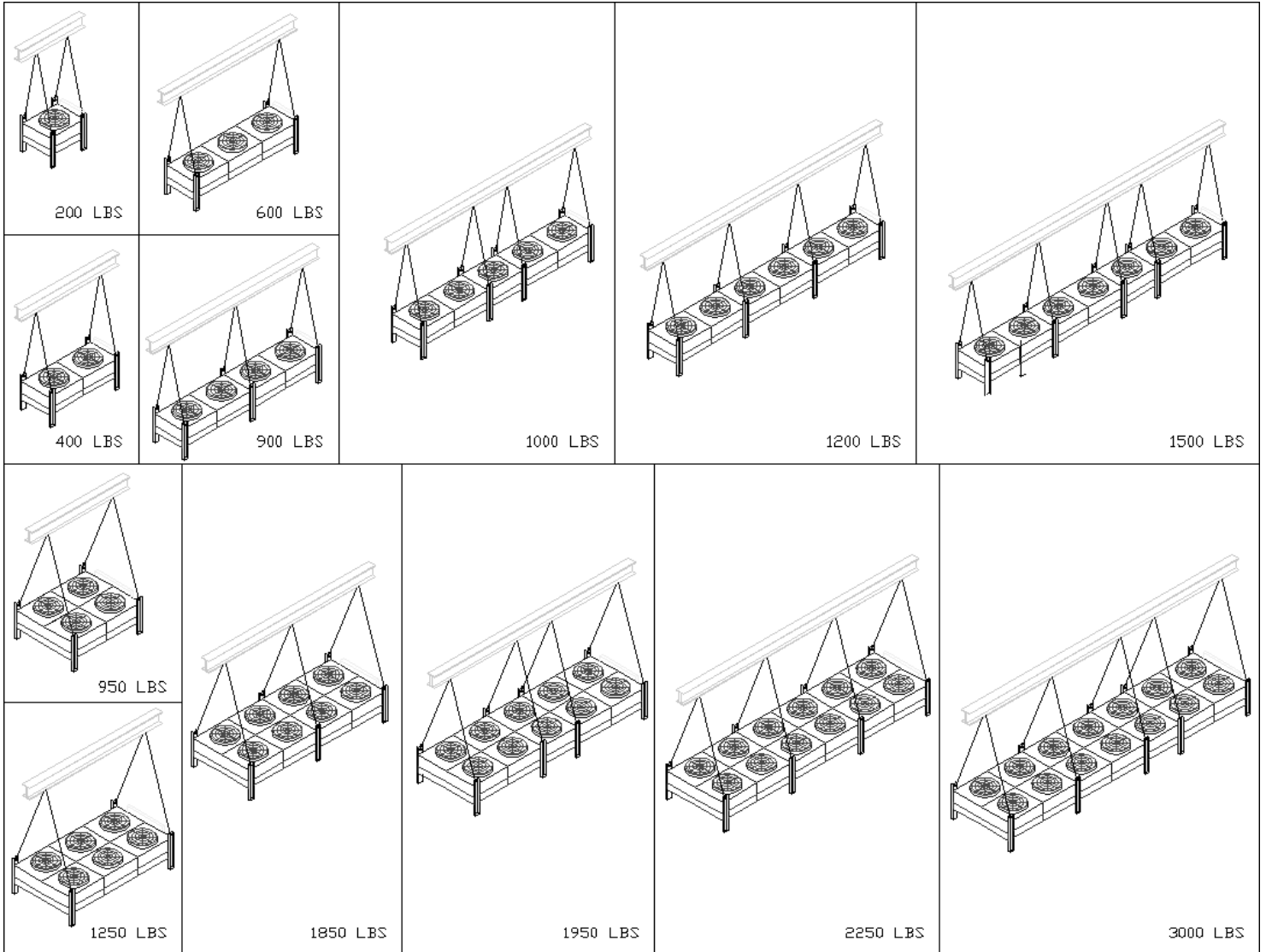

NOTE: STATIONARY LIFTING POINTS AND LIFTING PLATES FACTORY MOUNTED. OUTER SUPPORT LEGS (IF REQUIRED) SHIPPED LOOSE FOR FIELD INSTALLATION BY OTHERS WITH NECESSARY BOLTS, WASHERS AND NUTS INCLUDED, (SEE SECTION 5.1 FOR LEG MOUNTING INSTRUCTIONS). UNDER NO CIRCUMSTANCES SHOULD CONSIDER MANIFOLDS, ELECTRICAL ENCLOSURE(S) OR RETURN BENDS BE USE FOR LIFTING OR MOVING THE UNITS!

5 UNIT ASSEMBLY

5.1 Leg Assembly For 30" Fan Units – For Units with A, C, E, F, and K motors

Fluid Coolers with 30" diameter fans that blow air in a vertical up direction are supported by formed, mill galvanized channel legs that provide a standard 22" of clearance from the bottom of the leg to the bottom of the coil section. Install the legs on the unit before rigging the unit into place using the hardware provided with the unit. If extended legs are ordered to provide additional clearance, the leg attachment is the same as the standard leg. Support legs that are 48" or 60" in height will require a leg between every fan section and cross bracing for stability.

FIGURE 10 STANDARD 22" LEG ASSEMBLY

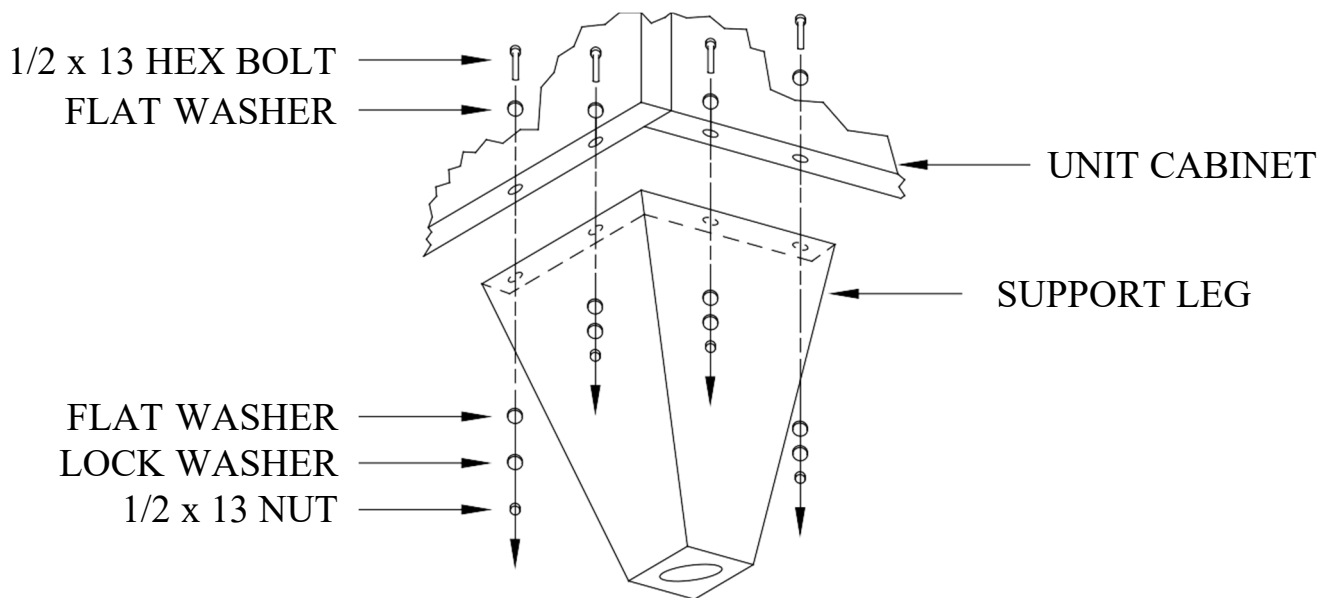

5.2 Horizontal Airflow Unit Base Support

Double-wide fluid cooler units with 30" diameter fans standing up with horizontal airflow will have heavy duty sheet metal supports running the length of the unit to support the weight of the unit. The supports have a hole pattern to bolt the unit to the base pad or structure that the unit will sit on (review drawing that comes with the unit for the hole pattern detail). The unit will also come with a loose set of metal angles to help support the unit horizontally. View drawing that comes with unit for support angle attachment location both to the unit and to the base pad or structure.

6 INSTALLATION AND PIPING

6.1 *Mounting the Unit*

The unit must be installed on a firm, level base to assure optimum unit performance. The mounting legs should be securely fastened at its base to the steel or concrete of the supporting base. For roof mounted installations, the steel supporting base holding the unit should be elevated above the roof and fastened to the columns or load bearing walls of the building. See Figure 12 for mounting examples.

6.2 *Interconnecting Piping for Double Wide Units*

Interconnecting piping for double-wide units should be as short and as direct as possible to the unit header connections. The fluid inlet connections are always on the air outlet side of the coil. If the fluid piping arrangement has a portion of the pipe at a higher elevation than the coil headers, a vent valve should be placed at the highest point of the piping. If the header sheet metal covers were removed for piping, replace the covers for header and return bend protection. See Figure 12 for suggested interconnecting piping support arrangements.

6.3 *Fluid Piping*

All jobsite piping to the unit should conform to the applicable local and state codes. Use the proper pipe sizes for the installation. Follow good commercial piping practices throughout the installation which includes properly bracing the lines.

AC&R type copper tubing should be used throughout. Cut tubing with a wheel-type cutter and not a hacksaw. Debur before assembly in the fittings. **NOTE:** If onsite tubing lengths used are not capped (i.e., are not perfectly clean), it should be dragged internally with a clean, lint-free rag before fabricating into the system. Soft solders are not to be used. Always clean all pipe and fitting areas that will be brazed with the proper grade emery cloth. Plan to use only oxy-acetylene brazing. A higher content silver brazing rod must be used to avoid excessive use of flux, to avoid it being pushed into the system piping, which will create problems later. Use a silver solder which contains sufficient silver content necessary for joint strength and flexibility yet requires minimum use of flux. For copper-to-copper joints, use a phos-copper solder with 6-8% silver content. Some easy-flow types require no flux, and the resultant joints are of maximum strength without brittleness. Nitrogen should be used to purge the air from the connecting tubing during brazing in order to prevent copper oxide formations.

For fluid coolers with threaded connections, use of a pipe thread compound (filler) or teflon tape is recommended when connecting to the system piping. Use opposing wrenches on the unit connection and the mating piping connection so that the minimum of the turning torque is applied to the unit connection stub and header.

For fluid coolers with flanged connections, the mating flange must be equally rated and sized. Review drawing that came with the unit for flange information.

A vent plug is installed at the highest point in the unit inlet header to facilitate the removal of internal air when filling or purging the system. The purging process should only be done with the pump system off and pressures equalized.

Consideration should be given that undersized piping lines will cause several problems in a fluid system. High pressure drops in the lines take away from the systems flow rate and capacity as well as resulting in excessive power usage.

Provisions must be made to accommodate expansion and contraction of the lines, especially if the lines have long run with few elbows or bends. The lines must also be adequately supported at frequent intervals in accordance with good piping practice. It is necessary that field bracing provide adequate support at the fluid cooler connections. See Figure 12 for suggested arrangements.

Pressure testing of the piping should be done as soon as the field piping has been completed. The test pressure should not exceed the unit UL nameplate pressure. Nitrogen may be used to increase the trace refrigerant pressure for leak testing. Shipping vibrations can stress joints thus producing operating leaks which would otherwise go undetected from just a low-pressure holding charge. Therefore, check for leaks at all joints before filling the system.

Field piping design must prevent the coil from being isolated from the expansion tank. See Figure 13 for typical piping. The fluid properties and circulation rate must be maintained to protect freezing.

FIGURE 12 UNIT MOUNTING AND PIPING

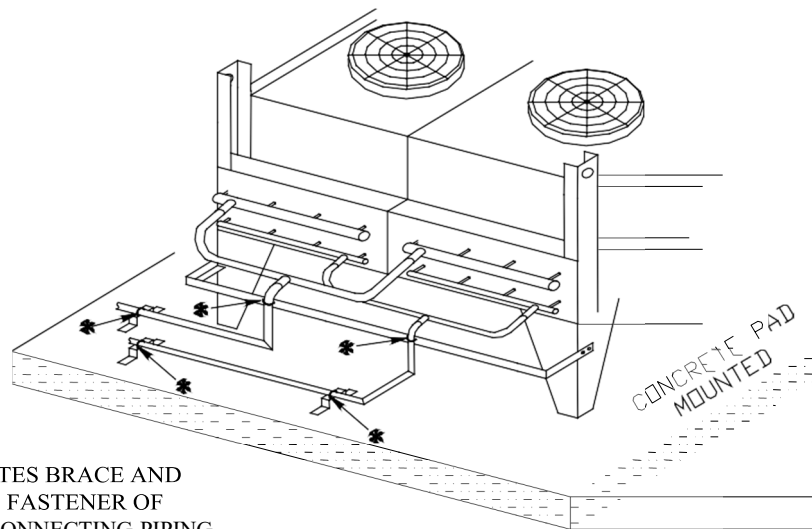

*DENOTES BRACE AND CLAMP FASTENER OF INTERCONNECTING PIPING TO FLUID COOLER UNIT

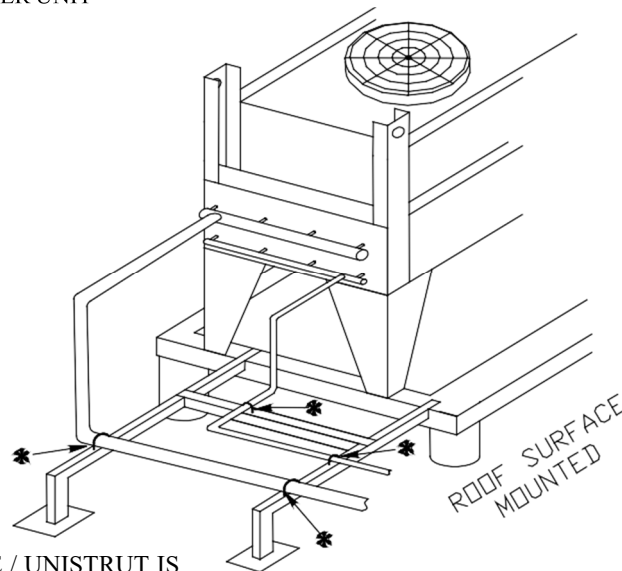

B-LINE / UNISTRUT IS THE PREFERRED PIPE CLAMPING MEANS

FIGURE 13 TYPICAL PIPING

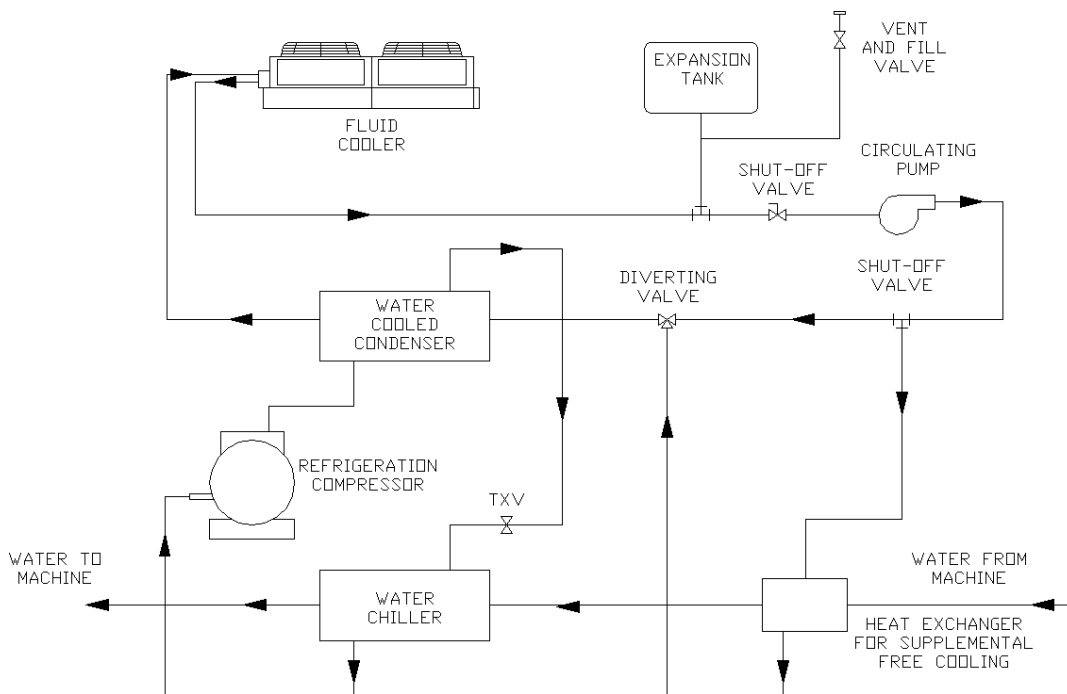

6.4 Recommended Fluids and Oils

Selection of fluid and percentage of fluid mixes depend on internal volume of the coil, type of application and freezing temperature of the fluid. Refer to table 11 for freezing temperature of fluids. Proper precautions need to be taken to prevent freeze damage during low ambient temperatures. Consult glycol vendor recommendations for specific freeze protection for installed location.

Common fluids that can be cooled include water, glycol, and refrigeration oil. These fluids and variety others can be simulated in our computer software program to optimize circuiting and calculate performance for the specific supply temperature, flow rate, and fluid type.

Krack offers fluid coolers with fluids and oils listed below. Available fluid options:

- Water
- Ethylene Glycol
- Propylene Glycol
- Calcium Chloride
- Trichloroethylene

Available refrigeration oil options:

- BSE170 Oil
- B100 Oil
- B320SH Oil
- B150SH Oil

Table 11 - Fluid Properties

Fluid	Fluid Viscosity (centipoise)	Fluid Thermal Conductivity (Btu/h·ft·°F)	Fluid Specific Heat (Btu/lb·°F)	Fluid Density (lb/ft ³)	Freezing Temp (°F)
Water	0.5297	0.372	1	61.64	32
Ethylene Glycol	0.9272	0.3	0.931	63.4	14.9
Propylene Glycol	1.1427	0.288	0.949	62.6	15.3
Calcium Chloride	7.658	0.441	1.354	167.22	-19
Trichloroethylene	1.0428	0.139	0.328	61.93	-123

6.5 Glycol Sludge Prevention

Glycol systems may be subject to sludge formation in coils due to one or more of the following causes:

- Reaction of the fluid with piping (zinc)
- Reaction of the fluid with water additives
- Reaction of the fluid with system dirt, pipe dope, oils, or solder flux

Glycol manufacturers offer a specially inhibited glycol (formulated for snow melting systems) which does not react with zinc. This glycol is also suitable for heat transfer systems. Glycol manufacturers also provide inhibitor check services on a regular basis.

6.6 Recommended Connection Size

System design must conform to all local and national codes, laws, and regulations applying to the site of installation. In addition, the safety code for mechanical refrigeration (ASME B31.5) should be followed as a guide for installation and operation practice. Refrigerant line sizes and piping techniques should be obtained from the ASHRAE guide or equivalent reference. Under no circumstances should the refrigerant connection size of the unit be used as the basis for sizing the lines.

7 ELECTRICAL

If the fluid cooler unit is equipped with an electrical power disconnect switch, ensure the switch is in the “OFF” position (preferably locked in this position before any electrical work is performed to the unit).

The fluid cooler units can be arranged at the factory so that each motor is wired to individual terminal blocks. In this case, each motor requires individual power wiring or can be wired to a fan cycling controlpanel requiring only one set of power wires. The fan cycling control panel can consist of a series of temperature controllers, which sense the outlet fluid temperature which turns fans on and off. Review theelectrical drawing that accompanies the unit.

Check fan blade clearances within the venturies so that each fan is horizontally centered in the venturi. Fan motors operating at higher elevations will draw lower than rated amps, as well as draw a less effective air volume across the coil surface. This is due to the reduced density of the higher altitude air resulting in reduced unit capacity. Consult factory if you suspect this situation.

7.1 Field Wiring

Field wiring should comply with NEC and local codes. The power supply voltage, phase, and frequency must match what is shown on the unit data plate. Only qualified electricians should work on the electrical portion of any unit installation.

7.2 Control Panel Nomenclature for A,B,C,E & F Motors –

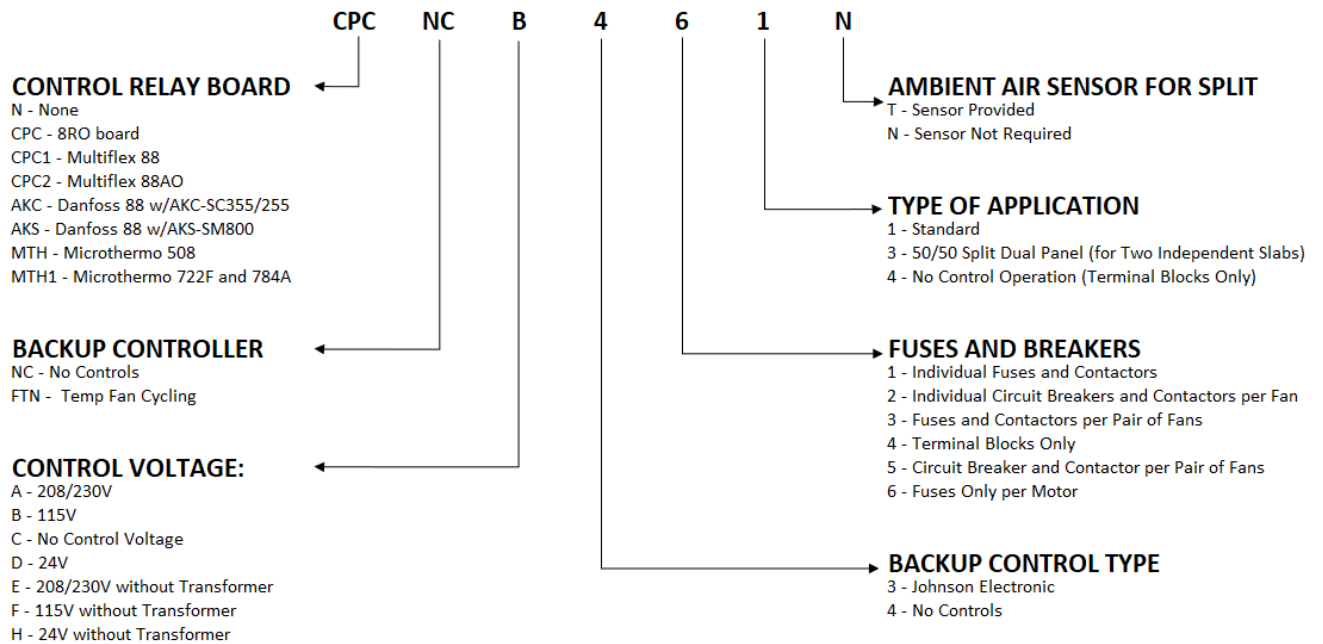

Control Panel Nomenclature for K Motor

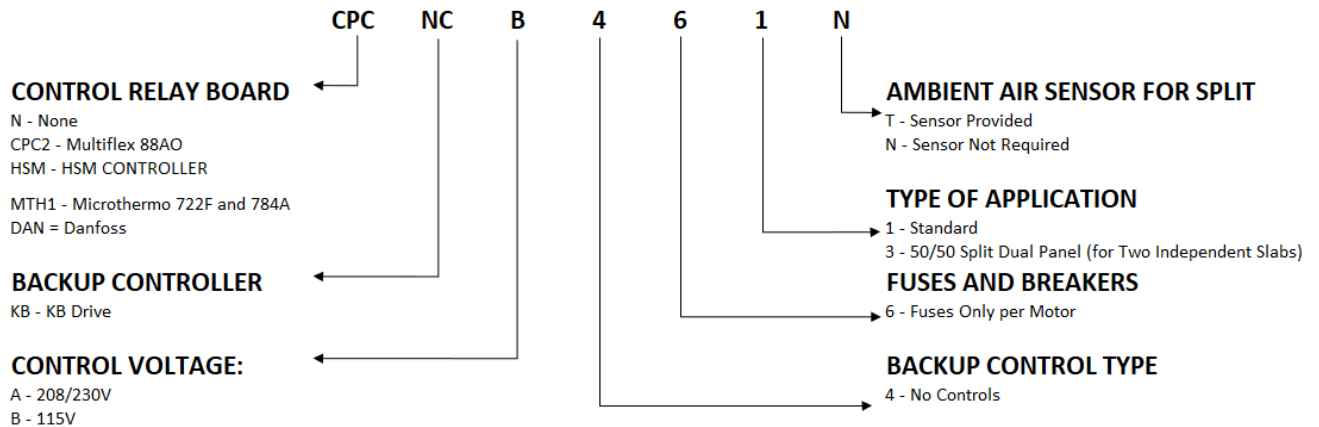

7.3 Motors Wiring

Primary protection to individual fan motor can be fuse/circuit breaker with contactors and fuse only. Krack gives the option of ‘only terminal pins’ for field wiring.

Figure 14 MOTOR WIRING

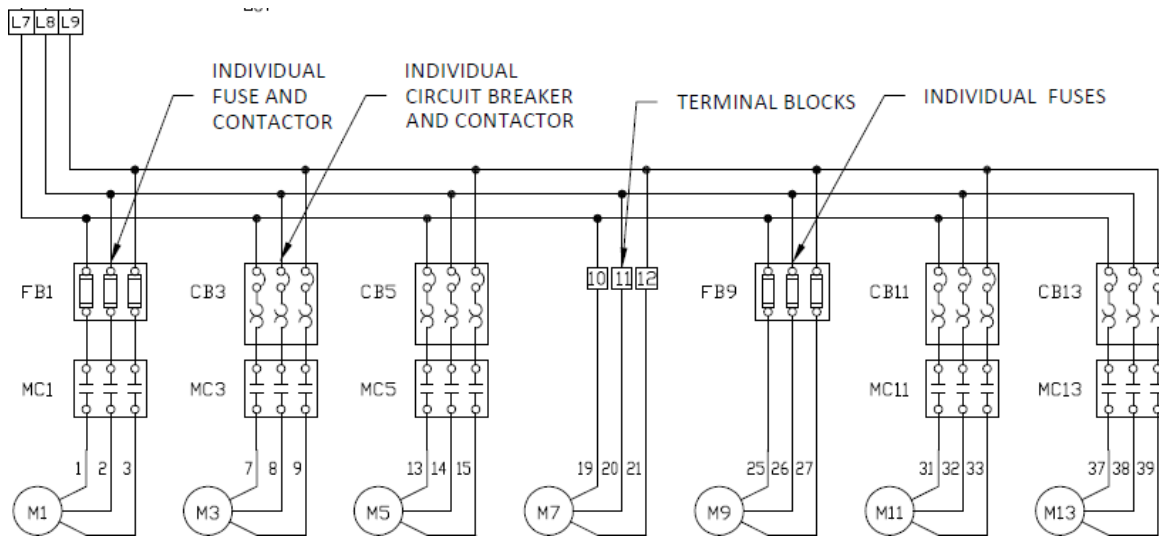
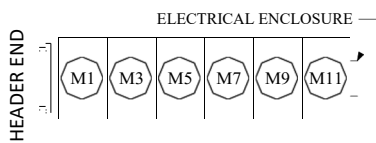

Figure 15 - Numbering of Fan Motors for Identification

Below picture shows the numbering of fan motors for identification.

1 Wide Units Fan Numbering



2 Wide Units Fan Numbering

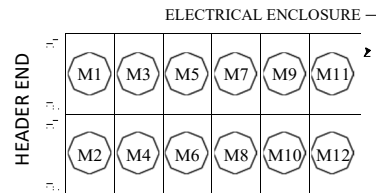

7.4 Motors Wired to Standard Fan Cycling Control Panel

The standard fan cycling control panel for fluid cooler units contains a series of temperature controllers. The fans cycle on and off from a signal by the temperature sensor. If the unit has one row of fans, the fan cycling controls turn the fans on or off individually. If the unit has two rows of fans, either adjoining pairs of fans or individual fans can be cycled depending upon the system requirements. Consult electrical drawing that arrived with the fluid cooler. The fan(s) nearest the headers are the first-on, last-off, and are continuously on when the pump is running. Figure 16 has typical motor wiring schematics.

Figure 16 FAN CYCLING WIRING DIAGRAMS

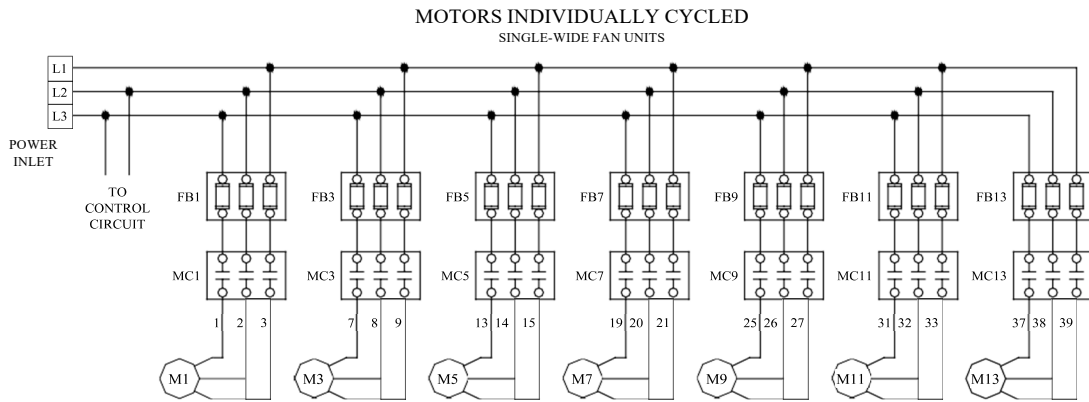
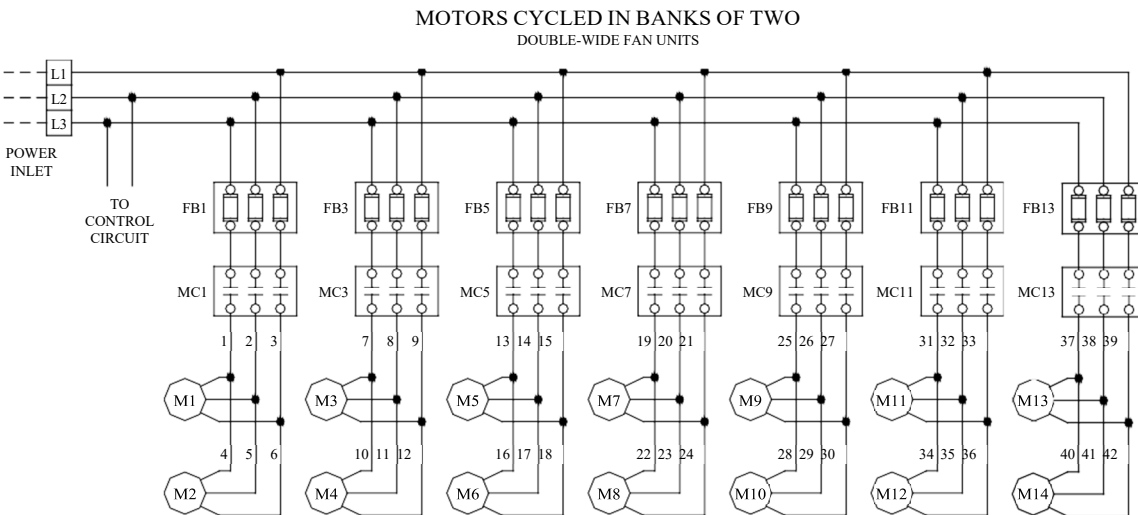

Figure 17 FAN CYCLING IN PAIRS WIRING DIAGRAMS



7.5 CONTROL PANEL WIRING DIAGRAMS

Control voltage for the unit can be a separate feed or it can be taken from the fan motor feed. In case of single power feed connection, a stepdown transformer will be used. Transformer sized based on primary, secondary voltages and amps required. Control voltage can be 208V-230V, 120V, and 24V.

Figure 18 CONTROL PANEL WIRING DIAGRAM

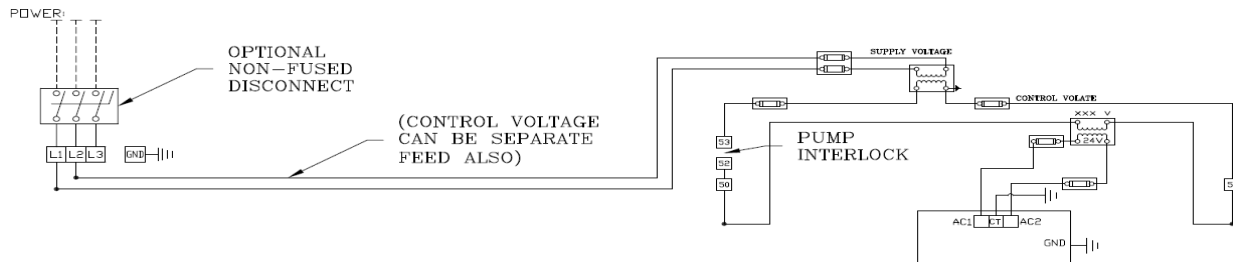

7.6 RELAY BOARD WIRING

Krack offers Emerson Multiflex boards, Danfoss, Microthermo, and Novar control boards with fluid coolers with for A,B,C,E, and F fan motors. For units with K motors, Emerson Multiflex, Danfoss, Microthermo, and HSM controller options are available. Review specific job drawing for further details.

Figure 19 Typical Relay Board Wiring –For 1 wide and 2 wide units.

1 Wide Units

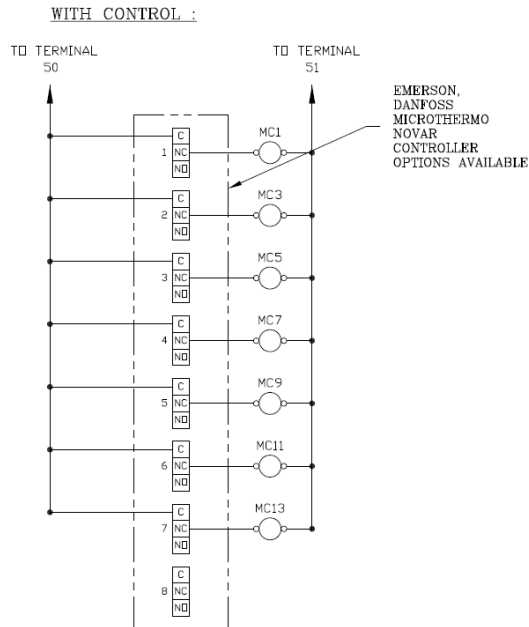

2 Wide Units

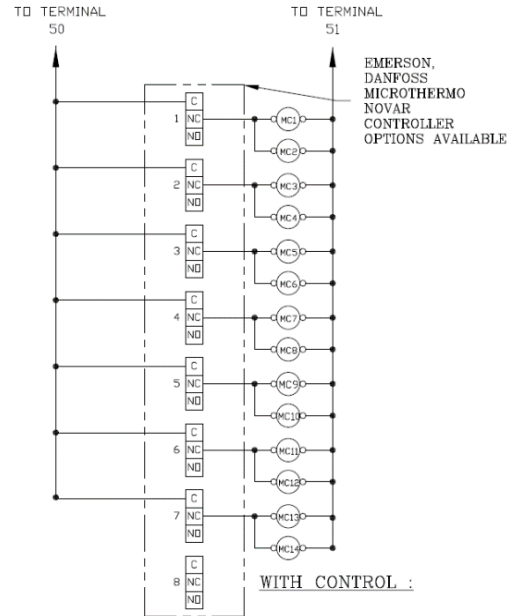

7.7 Back Up Controller Wiring

Krack offers Johnson Controls System 350 as a backup controller. **The operation of the fan cycle controller employed with a fluid cooler unit should be set up so that the fan or set of fans if a double wide unit, nearest the unit headers is/are the first fans on or last-off whenever the pump is running.**

Not complying with this condition can cause uneven rapid expansion and contraction of the unit core tubing contributing to tube failures. Violation of this condition is most often associated with electronic controllers and must be avoided through correct programming. This also means do not program the “header end” fans(s) for “equal run time.”

The excessive tube stress within the unit due to rapid expansion and contraction of the coil is caused by needless temperature swings as a result of incorrect fan cycling during cold weather. The header end fan(s) will cool the entering fluid and allow the remaining unit surface to cool the fluid at internal temperatures that are not a threat to the performance of the equipment.

To obtain the maximum life from the unit, as well as meet with warranty stipulations, the following field set-up is required:

- A) Always set the header end fan(s) to cycle first-on and last-off when a pump is operating.
- B) Do not set the fans to cycle-on more than 30 times per hour. The maximum short cycling is one minute on, one minute off.

Figure 20 Wiring Drawing – Back Up Controller

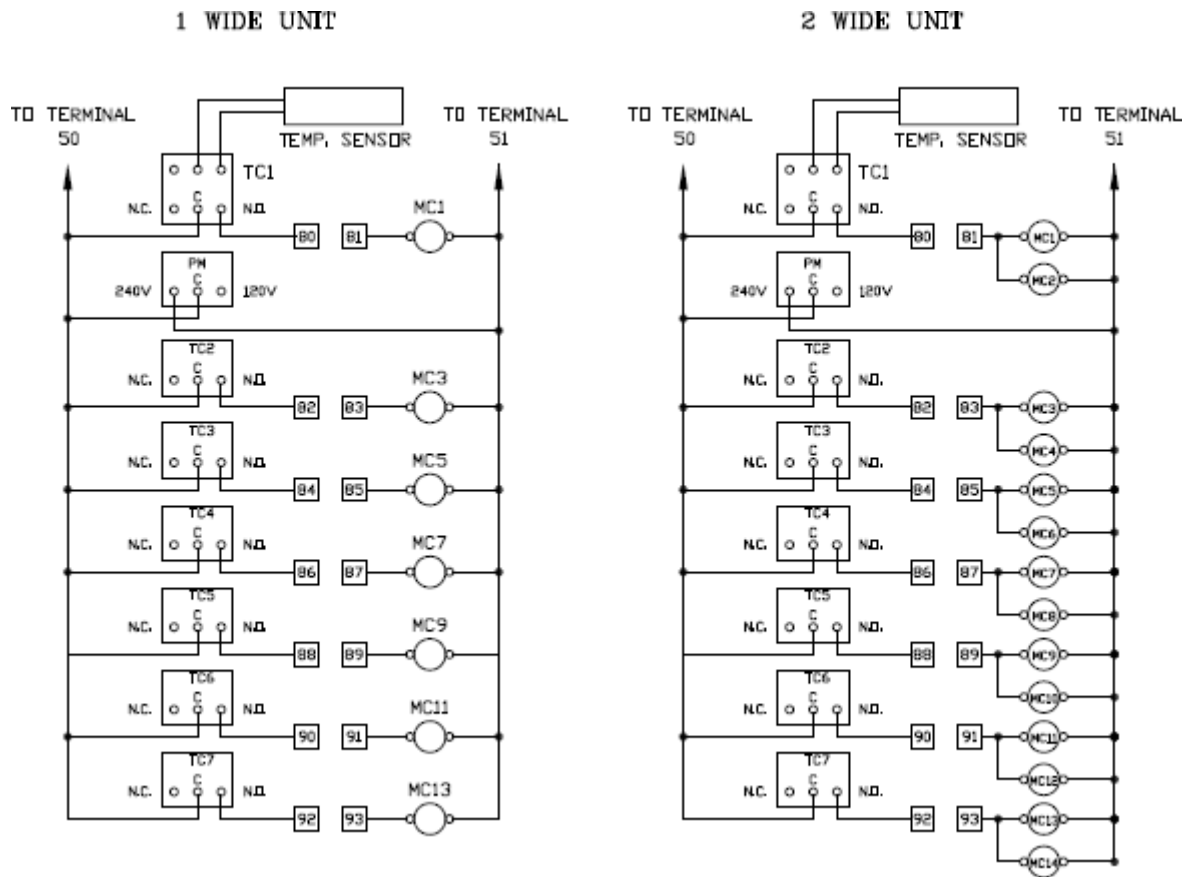

7.8 Control Settings

Table 13 contains the settings that the control panel components are set. If a control outside the Johnson controls System 350 series controller is used, consult the wiring schematic for the unit ordered.

7.9 Temperature Sensor

For units with factory-mounted fan cycling controls, the fluid temperature sensor is installed into the bottom, or fluid outlet, header to sense the discharge fluid temperature. On the end of the header, usually on the left side of the unit, a thermal well is installed into the header endcap and the temperature sensor is installed in the bulb well.

TABLE 12 CONTROL PANEL SETTINGS

		AMBIENT CONTROL TEMPERATURE SETTINGS (°F)						
TEMPERATURE CONTROL #		TC1	TC2	TC3	TC4	TC5	TC6	TC7
FAN MOTOR CONTACTOR NUMBER	Single Wide Units	MC1	MC3	MC5	MC7	MC9	MC11	MC13
	Double Wide Units	MC1 & MC2	MC3 & MC4	MC5 & MC6	MC7 & MC8	MC9 & MC10	MC11 & MC12	MC13 & MC14
SET		70						
OFFSET		--						
DIFF		15						
FAN ON		85						
FAN OFF		70						
SET		60	--					
OFFSET		--	15					
DIFF		10	10					
FAN ON		70	85					
FAN OFF		60	75					
SET		60	--	--				
OFFSET		--	10	15				
DIFF		10	10	10				
FAN ON		70	80	85				
FAN OFF		60	70	75				
SET		60	--	--	--			
OFFSET		--	5	10	15	20		
DIFF		5	5	5	5	5		
FAN ON		65	70	75	80	85		
FAN OFF		60	65	70	75	80		
SET		55	--	--	--	--	--	
OFFSET		--	5	10	15	20	25	
DIFF		5	5	5	5	5	5	
FAN ON		60	65	70	75	80	85	
FAN OFF		55	60	65	70	85	80	
SET		55	--	--	--	--	--	--
OFFSET		--	5	10	15	20	25	30
DIFF		5	5	5	5	5	5	5
FAN ON		55	60	65	70	75	80	85
FAN OFF		50	55	60	65	70	75	80

NOTE: MOTOR CONTACTORS WIRED TO “NC” CONTACT OF TEMPERATURE CONTROL. TEMPERATURE CONTROL SET IN “HEATING” MODE. SEE WIRING DIAGRAM.

7.10 VFD OPERATION

VFD Motor distribution block available for customer supplied VFD's.

FIGURE 21 TYPICAL VFD WIRING DIAGRAM –

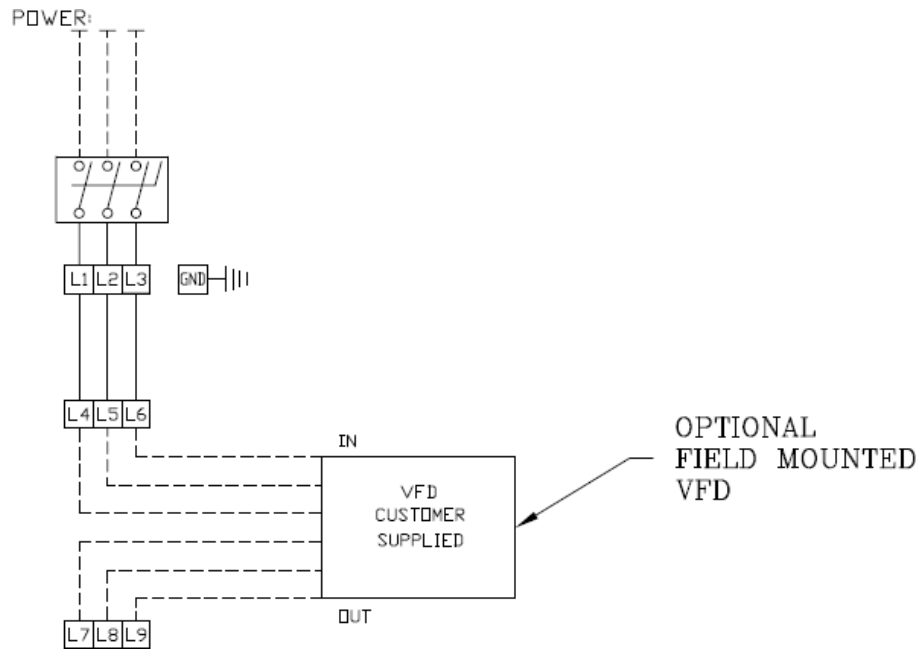

7.11 Wiring of Units with Vspeed K Motor

Vspeed variable speed fluid coolers use Nidec BPM motors which use KB VFD's. The VFD's come factory mounted in the control panel. Airflow is increased/decreased across the fluid cooler coil surface by modulating variable speed fans.

The below figure shows wiring schematics for the drives and motors.

Figure 22 Typical One Wide Unit Drawing with K Motor

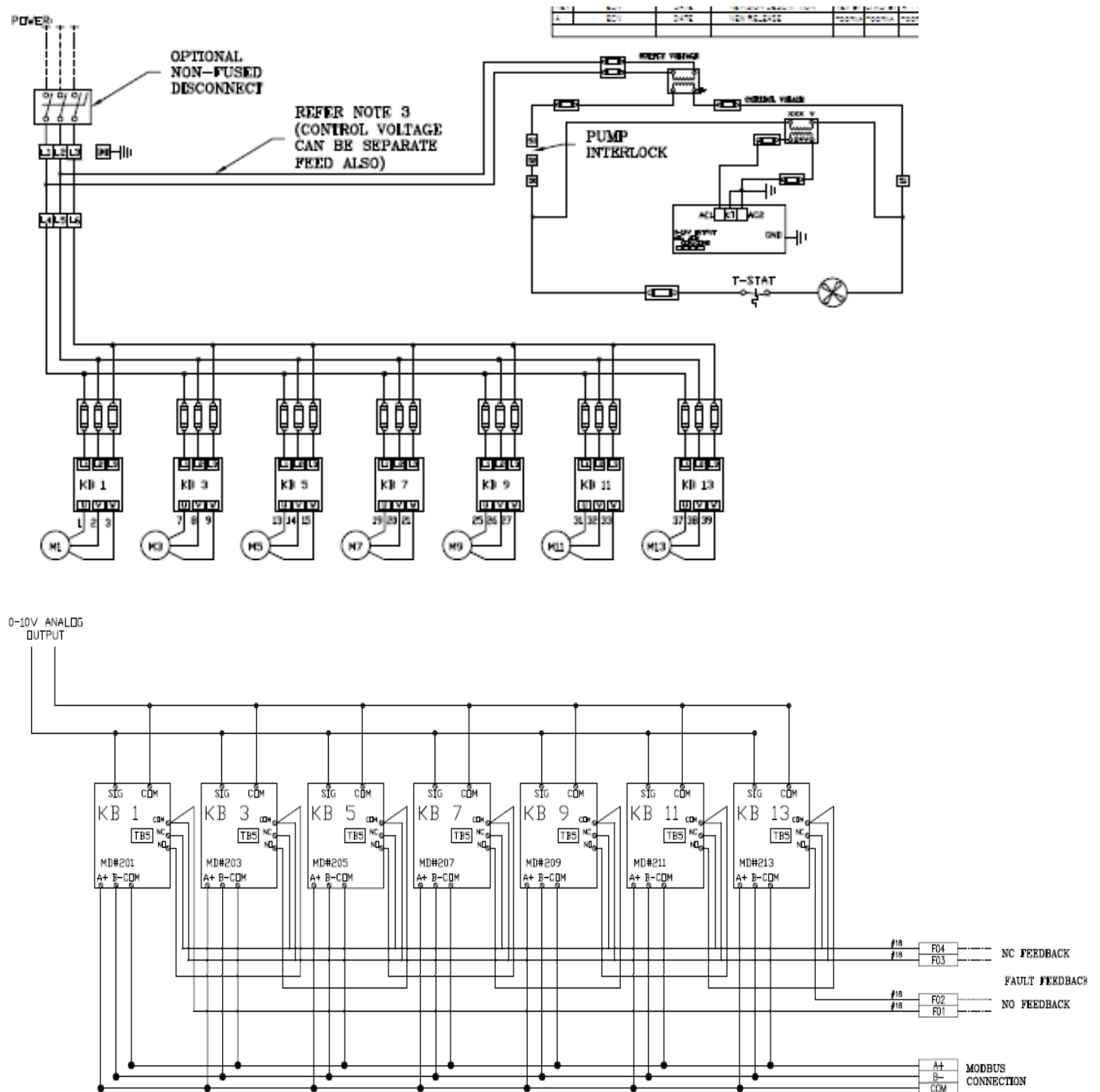
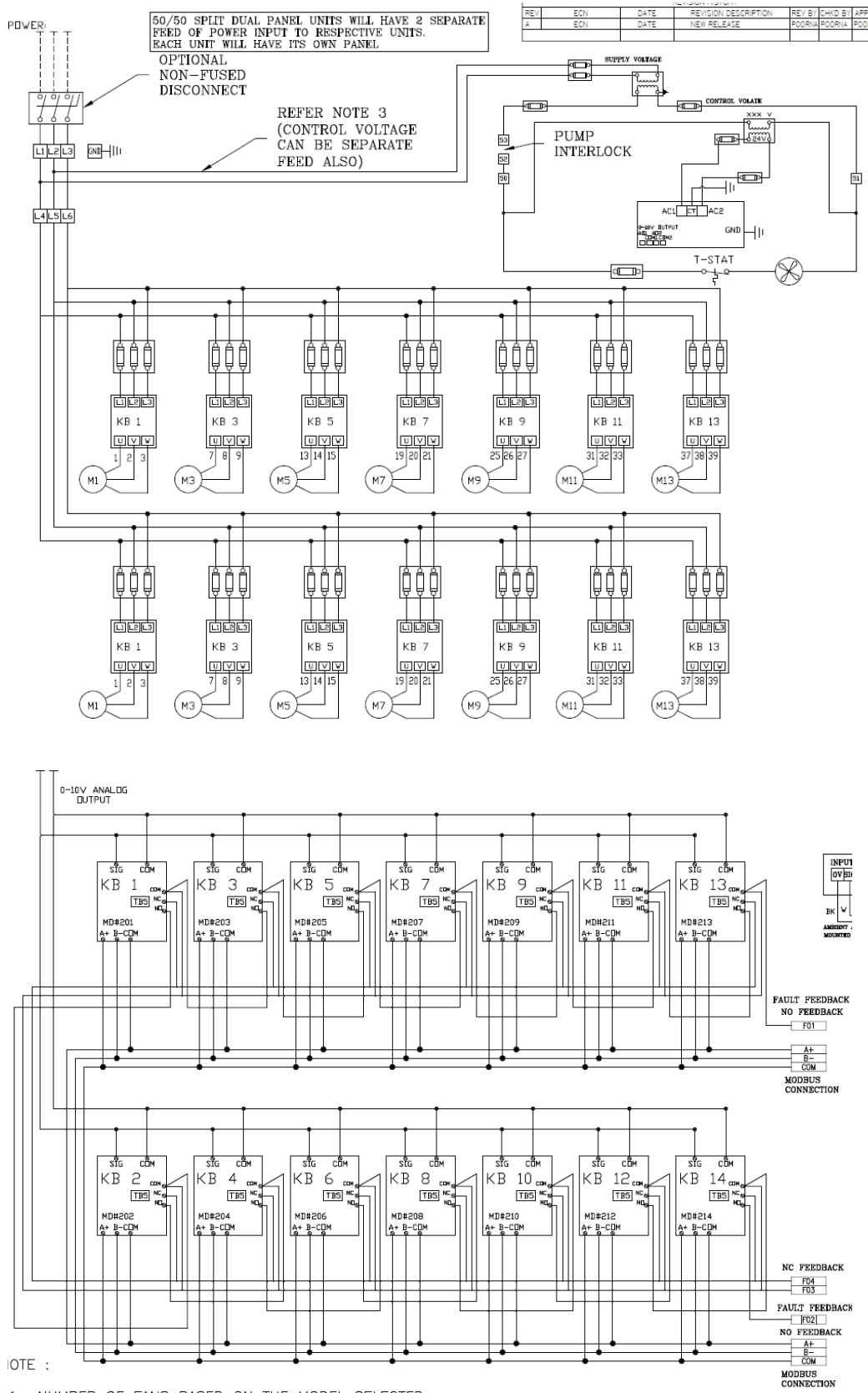

FIGURE 23 Typical Two Wide Unit Drawing with K Motor



7.12 KB DRIVE SPECIAL SETTING

FIGURE 24: Factory Installed Jumper

Ensure there is a jumper (#18 Gauge wire) installed between FWD and COM switches to allow the motor to run.

TERMINAL BLOCK TB1 CONNECTIONS AND JUMPERS J1/J2 SETTINGS

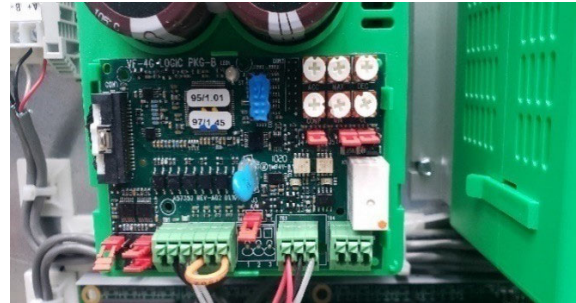
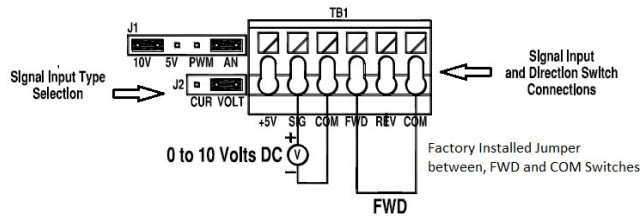

SPECIAL NOTE for Failure Mode – In the event of a drive failure or suspected failure, **the drive should not be by-passed**. The motor will not operate without the drive. Damage to the motor may result and will void the warranty.

KB DRIVE TRIMPOT SETTING

FIGURE 25 KB Drive Minimum and Maximum Speed Setting

LEVITON CONDENSER K- MOTOR RPM	MOTOR FLA
Max = 1140 RPM	Min = 0 RPM
	230/3 460/3
	5.4 3.0

SPECIAL NOTES :-
FOR MAX SPEED KEEP THE KNOB IN 11.5 O'CLOCK POSITION AS SHOWN IN THE PICTURE BELOW.
FOR MIN SPEED KEEP THE KNOB IN MIN POSITION AS SHOWN IN PICTURE BELOW.

ADJUSTABLE TRIMPOTS – ALL TRIMPOTS ARE FACTORY SET.

ACC – ACCELERATION (RANGE: 1.0–20 SECONDS, DEFAULT: 10.5 SECONDS) – DO NOT CHANGE SETTING
MAX – MAXIMUM SPEED (RANGE: 547 –1800 RPM, DEFAULT: 1140 RPM) – FACTORY SET TO MAX SPEED AS SHOWN IN TABLE
DEC – DECELERATION (RANGE: 1.0–20 SECONDS DEFAULT: 10.5 SECONDS) – DO NOT CHANGE SETTING
MIN – MINIMUM SPEED (RANGE: 0–450 RPM, DEFAULT: 0 RPM) – FACTORY SET TO MIN SPEED AS SHOWN IN TABLE ABOVE
CL – CURRENT LIMIT (RANGE: 0.37–6.97 AMPS, DEFAULT: 5.6AMPS) – FACTORY SET TO FLA OF THE MOTOR AS SHOWN IN THE
COMP – SLIP COMPENSATION (NOT USED) – DO NOT CHANGE THE SETTING

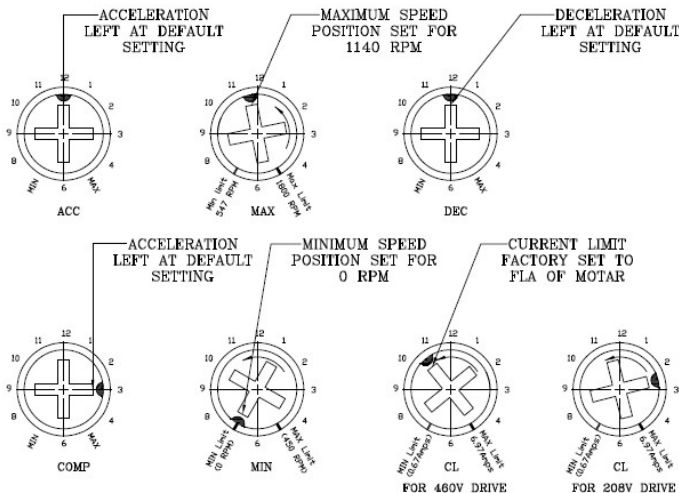

7.13 ELECTRICAL MOTOR FLA DATA

Table 14 Shows the FLA of the motor measured at different input voltages. Refer to the individual unit drawing for MCA and MOP values.

Table 13 Fan Motor Amps

MOTOR TYPE	FLA OF MOTOR					
	A-230/1/60	K-230/3/60	U-380/3/50	L-380/3/60	M-460/3/60	P-575/3/60
A	N/A	4.8	2.3	N/A	2.4	1.8
B	4.2	2.5	N/A	N/A	1.3	1.0
C	N/A	6.9	2.9	N/A	3.3	2.5
E	N/A	3.4	1.4	N/A	1.6	1.5
F	N/A	5.4	2.1	3.0	2.5	2.5
K	N/A	5.4	N/A	N/A	3.0	N/A

7.14 FAN MOTOR COMBINATION (KW)

Table 14a & 14b Motor KW Ratings at 60Hz and 50Hz

Table 15a KW Rating at 60 Hz

MODEL	A	B	C	E	F	K
11208	0.90	0.61	1.07	0.27	1.17	1.15
11210	0.91	0.61	1.08	0.28	1.17	1.15
11212	0.92	0.61	1.09	0.28	1.18	1.16
11308	0.92	0.61	1.10	0.28	1.19	1.17
11310	0.93	0.62	1.13	0.28	1.21	1.19
11312	0.94	0.62	1.15	0.29	1.22	1.20
11408	0.94	0.63	1.15	0.29	1.22	1.20
11410	0.96	0.63	1.17	0.29	1.24	1.22
11412	0.98	0.64	1.20	0.30	1.27	1.25

Table 15b KW rating at 50 Hz

MODEL	A	B	C	E	F	K
11208	0.75	0.51	0.89	0.23	0.98	0.96
11210	0.76	0.51	0.90	0.23	0.98	0.96
11212	0.77	0.51	0.91	0.23	0.98	0.97
11308	0.77	0.51	0.92	0.23	0.99	0.98
11310	0.78	0.52	0.94	0.23	1.01	0.99
11312	0.78	0.52	0.96	0.24	1.02	1.00
11408	0.78	0.53	0.96	0.24	1.02	1.00
11410	0.80	0.53	0.98	0.24	1.03	1.02
11412	0.82	0.53	1.00	0.25	1.06	1.04

Watts shown are for a single fan and are multiplied by the number of the fans for units with more than one fan.

7.15 ELECTRICAL MOTOR DATA AT 60 Hz

Table 15 Fan Motor Ratings at 60Hz

MOTOR TYPE	MOTOR RPM @60Hz	MOTOR HP @60Hz	MOTOR AMPS @ 380/60/3
A	700	0.75	2.3
C	700	1	2.9
E	420	0.33	1.4
F	950	1	2.1
K	950	1	TBD

- Electrical Motor KW rating (power consumption) at 60Hz to be 5/6 x power consumption (KW) (which is shown table above).
- 60Hz Motor are offered only at 380V
- Motor Type B is not offered with 380V/60Hz option

8 INSPECTION AND CLEANING

If the fluid cooler unit is equipped with an electrical power disconnect switch, ensure the switch is in the “OFF” position preferably locked in this position before any electrical work is performed on the unit.

Without a disconnect switch on the unit, make sure all power to the unit is off from the source. Electrical connections should be inspected periodically and tightened if required. Loose electric connections can cause severe electrical damage as well as nuisance trip out and burnouts. During the unit start up, phase check the fans for the correct rotation. While the fans are rotating, the airflow should pass through the coil surface first, flow through the fan and away from the unit. If the fans are pushing the air into the coil surface, the fans are rotating in the wrong direction and the motor wiring needs to be corrected.

8.1 PRE-STARTUP AND OPERATION INSPECTION

After the installation is completed, a review of the following items should be performed before the system is placed into operation:

- Secure all screw connections
- Check for all leakage
- Unit cleanliness and corrosion

Check electrical connections, fan blade set screws, fan motors, guards, and all other fasteners for tightness. Be sure the thermostatic expansion valve bulb is properly located, strapped, and insulated.

With the system operating, check the supply voltage. It must be within +/- 10% of the voltage marked on the unit nameplate.

LISTEN CAREFULLY to the unit to make sure there are no unusual sounds. Sounds such as a noisy motor, the fan(s) scraping on the housing, or loose fasteners allowing parts to rattle need to be addressed immediately before continued unit operation.

8.2 CLEANING

For maximum efficiency, air-cooled coils should be cleaned of lint and dust every 4 to 6 months so that airflow is not restricted. More frequent cleaning may be necessary under severe conditions. Use a water spray with an approved cleaning solution for finned tube coils such as those used on air conditioning units. The water and cleaning solution should be sprayed on the coil surface opposite the direction of the fan airflow direction. The fluid cooler units are equipped with convenient access panels to allow the cleaning spray wand to be inserted into the fan cabinet above the coil section and below each motor and fan. When cleaning unit, it must not be in operation and all electrical power should be disconnected.

8.3 PREVENTIVE MAINTENANCE

A preventive maintenance schedule should be established as soon as the unit is installed. The unit should be inspected periodically for proper operation and buildup of frost and debris.

9 REPLACEMENT PARTS LIST

Figure 263 - REPLACEMENT PARTS

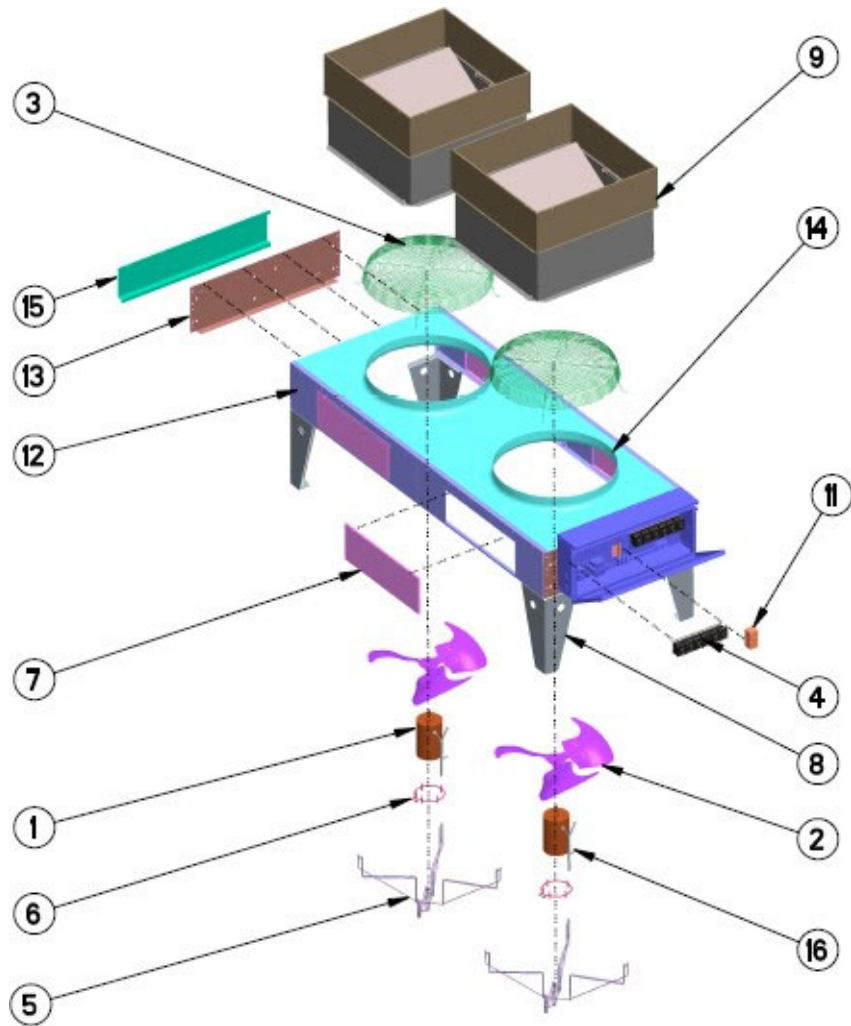

Table 16 REPLACEMENT PARTS

Item	General Description	Options Description	Krack BOM Part Number
1	MOTOR		
	MOTOR E	0.5 HP 208-230/460/60/3 575 RPM 0.5 HP 575/60/3 575 RPM	E206880IN E318680
	MOTOR B	0.5 HP 208-230/460/3/60 1140 RPM 0.5 HP 575/3/60 1140 RPM	11525IN E208100
	MOTOR A	1 HP 208-230/460/60/3 INV DUTY 850 RPM 1 HP 575/60/3 850 RPM	11503IN E205307IN
	MOTOR C	1.5 HP 230/460/3/600 INV DUTY 850 RPM 1.5 HP 575/60/3 850 RPM	E151976IN E151976A
	MOTOR F	1.5 HP 230/460/60/3 INV DUTY 1140 RPM 1.5 HP 575/60/3 1140 RPM	E205492IN E206689IN
	MOTOR K	MOTOR-1.5HP 240V 50-60Hz 3P 120-1200RPM MOTOR-1.5HP 460V 50-60Hz 3P 120-1200RPM Drive 460V 50-60Hz KB Drive 240V 50-60Hz KB	3055269 3080452 3080453 3059065
2	FAN	24" DIA. CCW 5/8" BORE	E206876
		30" DIA. CW 5/8" BORE	E205493
		30" DIA. CW 5/8" BORE	112730
		30" DIA. CW 5/8" BORE	E151977
		30" DIA FOR E205492IN, E206689IN	E208056
		30" DIA FOR 11503IN, E205307IN	E208057
		30" DIA FOR E151976IN, E151976A	E208058
		30" DIA 25 DEG CW 5/8" BORE	112720
3	FAN GUARD	24"	E82691
		30"	E280792
4	MOTOR CONTACTOR	24V	E205170
		110V	107480
		230V	E150076
5	BRACKET	MOTOR MTG BRACKET FAN UNIT (2 PER MOTOR)	E208055
		MOTOR MTG BRACKET FOR 30" FAN UNIT (2 PER MOTOR)	E280793
6	MOTOR MTG RING	MOTOR MTG RING FAN UNIT (1 PER MOTOR)	800340
7	MOTOR SERVICE DOOR PANEL	MOTOR SERVICE DOOR PANEL	E86121
8	SUPPORT LEG	22" FIELD ASSEMBLED SUPT LEGS	E280914
		LEV SUPT LEG RECR SQ 30" HIGH	E281663
		SPECIAL SUPPORT LEG 36" HIGH	E281653A

		41.5" FIELD ASSEMBLED SUPT LEG LEV SUPT LEG 48" FIELD ASSY LEV SUPT LEG 60" FIELD ASSY	E280915 E203522A E203580A
9	GRAVITY DAMPER/LOUVER	LAVB LAVA, C, E, F	CE82700 CE280870
10	PHASE MONITOR	230V 460V 575V	10989A E201708A BN04257A
11	CONTROLS	A350AB-1 TEMPERATURE CONTROLLER Y350 R-1 POWER MODULE A99BC-300 TEMPERATURE SENSOR (9.75 FEET) S350AA-1 ADDER MODULE (TEMPERATURE) A99BC-1500C TEMP SENSOR 50 FT D350AA-1 DISPLAY MODULE	E205533 E205534 E205564 E205535 E206053 E205536
12	PLENUM PANELS	SERVICE DOOR SIDE SERVICE PNL SIDE NO DOOR END/CENTER 1W* END/CENTER 2W* CENTER 2W W/FRAME* CENTER 1W W/FRAME* PARTITION 2W PARTITION 2W W/FRAME	E86121 E203436 E203581 E203433 E203434 E203451 E203450 E203435 E203452
13	SHELF MOUNT	LEV2 PLENUM END/CTR SHELF MNT 1W LEV2 PLENUM END/CTR SHELF MNT 2W LEV2 PLENUM CTR SHELF W/FRM 1W LEV2 PLENUM CTR SHELF W/FRM 2W MTR SUPT SHELF UPPER 182-215T MTR SUPT SHELF LOWER 182-215T MOTOR SHELF 36" LENGTH	E208039 E208077 E208101 E208102 D256472 D256473 820390
14	FAN PANELS	LEV2 FAN PNL 30" 1W & 2W NARROW LEV2 FAN PNL 30/24" 1W & 2W NARROW LEV2 FAN PNL 30" 2W LEV2 FAN PNL 30"W/24" FAN 2W 24" STD FAN PANEL	E87128P E208168P D256804P E208167P E86115P
15	COVERS	LEV2 COVER RETURN BEND LEV2 HEADER COVER LEV2 HEADER COVER DBL CIRC LEV2 HEADER COVER DBL CIRC W/FRAME LEV RETURN BEND COVER 24" FAN HEADER COVER LEV-B	E203432 E203431 E204989A E204989F E86127 E208165
16	WIRE HARNESS LEV2	WHA-P399-200C ACVV-W-F-G 1FAN WIRE HARNESS	E207054 805870

	LEV2 WIRE HARNESS 2F-(2W)4F LH	80588RB
	LEV2 WIRE HARNESS (2W)4F RH	80589RB
	LEV2 WIRE HARNESS 3F-(2W)6F LH	80590RB
	LEV2 WIRE HARNESS (2W)6F RH	80591RB
	LEV2 WIRE HARNESS 4F-(2W)8F LH	80592RB
	LEV2 WIRE HARNESS (2W)8F RH	80593RB
	LEV2 WIRE HARNESS 5F-(2W)10F LH	80594RB
	LEV2 WIRE HARNESS (2W)10F RH	80595RB
	LEV2 WIRE HARNESS 6F-(2W)12F LH	80596RB
	LEV2 WIRE HARNESS (2W)12F RH	80597RB
	ACVB-I 1 LH WIRE HARNESS	E83149
	LEV2-B WIRE HARNESS 2F-(2W)4F LH	E83150RB
	LEV2-B WIRE HARNESS (2W)4F RH	E83151RB
	LEV2-B WIRE HARNESS 3F-(2W)6F LH	E83152RB
	LEV2-B WIRE HARNESS (2W)6F RH	E83153RB
	LEV2-B WIRE HARNESS 4F-(2W)8F LH	E83154RB
	LEV2-B WIRE HARNESS (2W)8F RH	E83155RB
	LEV2-B WIRE HARNESS 5F-(2W)10F LH	E83156RB
	LEV2-B WIRE HARNESS (2W)10F RH	E83157RB
	LEV2-B WIRE HARNESS 6F-(2W)12F LH	E83158RB
	LEV2-B WIRE HARNESS (2W)12F RH	E83159RB
	LEV2-B WIRE HARNESS 2F-(2W)14F LH	E83160RB
	LEV2-B WIRE HARNESS (2W)14F RH	E83161RB



Use your QR reader to
reference current document
version on www.krack.com.



Krack, a Hussmann Corporation brand
1049 Lily Cache Lane, Suite A
Bolingbrook, Illinois 60440
Ph: 630.629.7500

www.krack.com
www.hussmann.com