



SM/SV Series

SPACE MASTER UNIT COOLERS

Installation and Operation Manual





Part Number: E316008_K

Products that provide lasting solutions.



ANSI Z535.5 DEFINITIONS

-  • **DANGER** – Indicate[s] a hazardous situation which, if not avoided, will result in death or serious injury.
-  • **WARNING** – Indicate[s] a hazardous situation which, if not avoided, could result in death or serious injury.
-  • **CAUTION** – Indicate[s] a hazardous situation which, if not avoided, could result in minor or moderate injury.
- **NOTICE** – Not related to personal injury – Indicates[s] situations, which if not avoided, could result in damage to equipment.

Environmental Concerns

Hussmann recommends responsible handling of refrigerants that contain Chlorine, Fluorine and Carbon (CFCs) and those that contain Hydrogen, Chlorine, Fluorine, and Carbon (HCFCs). Only certified technicians may handle these refrigerants. All technicians must be aware and follow the requirements set forth by the Federal Clean Air Act (Section 608) for any service procedure being performed on this equipment that involves refrigerant. Additionally, some states have other requirements that must be adhered to for responsible management of refrigerants.



This warning does not mean that Hussmann products will cause cancer or reproductive harm, or is in violation of any product-safety standards or requirements. As clarified by the California State government, Proposition 65 can be considered more of a ‘right to know’ law than a pure product safety law. When used as designed, Hussmann believes that our products are not harmful. We provide the Proposition 65 warning to stay in compliance with California State law. It is your responsibility to provide accurate Proposition 65 warning labels to your customers when necessary. For more information on Proposition 65, please visit the California State government website.

 **WARNING**

PERSONAL PROTECTION EQUIPMENT (PPE)

Only qualified personnel should install and service this equipment. Personal Protection Equipment (PPE) is required whenever servicing this equipment. Wear safety glasses, gloves, protective boots or shoes, long pants, and a long-sleeve shirt when working with this equipment. Observe all precautions on tags, stickers, labels and literature attached to this equipment.



 **CAUTION**

This manual was written in accordance with originally prescribed equipment that is subject to change. Hussmann reserves the right to change all or part of the equipment for future stores such as, but not limited to, controllers, valves and electrical specifications. It is the installers responsibility to reference the refrigeration drawings supplied for each installation, as directed by the Engineer of Record.

 **CAUTION**

Contractors shall strictly adhere to specifications provided by the Engineer of Record (EOR), as well as US Environmental Protection Agency regulations, OSHA regulations, and all other federal, state and local codes. This work should only be done by qualified, li- censed contractors. There are numerous hazards, not limited to, but including: burns due to high temperatures, high pressures, toxic substances, electrical arcs and shocks, very heavy equipment with specific lift points and structural constraints, possible acid exposure, food and product damage, public safety, noise, and possible environmental damage. Never leave operating compressors unattended during the manual soft-start process. Always power rocker switches off when unattended.

TABLE OF CONTENTS

1	RECEIPT OF EQUIPMENT	4
1.1	INSPECTION	4
1.2	LOSS OF GAS HOLDING CHARGE	4
2	ASSEMBLY OF COMPONENTS	4
2.1	SHIPPED LOOSE PARTS- LONG THROW ADAPTERS	4
3	RIGGING INSTRUCTIONS	4
3.1	RIGGING INSTRUCTIONS	4
4	UNIT INFORMATION AND DIMENSIONS	4
4.1	MODELS COVERED	4
4.2	UNIT DIMENSIONS	6
5	UNIT LOCATION AND MOUNTING	6
5.1	UNIT LOCATION	6
5.2	MOUNTING	7
6	PIPING INSTALLATION	7
6.1	DRAIN LINE	7
6.2	REFRIGERATION PIPING	8
6.3	EVACUATION AND LEAK TEST	9
6.4	SM GAS DEFROST PIPING	9
6.5	REFRIGERANT DISTRIBUTOR NOZZLES	11
6.6	EXPANSION VALVE	13
7	ELECTRICAL	13
7.1	FIELD WIRING	13
7.2	ELECTRICAL DATA	13
7.3	AIR DEFROST SEQUENCE OF OPERATION	15
7.4	ELECTRIC DEFROST SEQUENCE OF OPERATION	16
7.5	HOT GAS DEFROST SEQUENCE OF OPERATION	20
7.6	DUAL SPEED MOTOR SEQUENCE OF OPERATION	20
7.7	VARIABLE SPEED MOTOR SEQUENCE OF OPERATION	20
7.8	VARIABLE SPEED MOTOR WITH SYSTEM 450 SEQUENCE OF OPERATION	20
7.9	KB DRIVE SPECIAL SETTING	20
7.10	INTERLOCKING SINGLE COMPRESSOR UNIT WITH KRACK COILS	205
8	START UP	26
8.1	PRE-STARTUP	26
8.2	OPERATION CHECKOUT	27
9	PREVENTATIVE MAINTENANCE	27
9.1	DRAIN PAN	27
9.2	COIL AND CABINET	288
9.3	FAN GUARD OR LONG THROW ADAPTER REPLACEMENT	288
9.4	FAN REPLACEMENT	288
9.5	UNIT MOTOR REPLACEMENT	288
9.6	ELECTRIC DEFROST HEATERS	28
10	TROUBLESHOOTING CHART	29
11	REPLACEMENT PARTS LIST	30

TABLE OF CONTENTS

CHARTS

TABLE 1 UNIT DIMENSIONS	6
TABLE 2 CHECK VALVES KITS	11
TABLE 3 DISTRIBUTOR NOZZLE CAPACITIES – TONS OF REFRIGERANT	12
TABLE 4 SM MOTOR ELECTRICAL DATA (AMPS)	13
TABLE 5 SV MOTOR ELECTRICAL DATA (AMPS)	13
TABLE 6 SM (E) EDL HEATERS ELECTRICAL DATA and SM (P) KGE & (H) HGE HEATERS ELECTRICAL DATA	14
TABLE 7 RECOMMENDED (SPST) FAN DELAY THERMOSTAT SETTINGS FOR KGE/HGG)	22
TABLE 8 VARIABLE SPEED MOTOR SPEED SPEED	23
TABLE 9 TROUBLING SHOOTING CHART	29
TABLE 10 REPLACEMENT PART LIST	31

FIGURES

FIGURE 1 MODEL KEY	5
FIGURE 2 UNIT DIMENSIONS	6
FIGURE 3 DRAIN LINE	7
FIGURE 4 PIPE JOINING	7
FIGURE 5 MULTIPLE UNIT COOLERS CONTROLLED BY A SINGLE SOLENOID	8
FIGURE 6 MULTIPLE UNIT COOLERS CONTROLLED BY MULTIPLE SOLENOIDS	9
FIGURE 7 GAS DEFROST PIPING DIAGRAMS	9
FIGURE 8 (A) AIR DEFROST WIRING DIAGRAM MOTOR TYPE C – AIR DEFROST	15
FIGURE 9 (A) AIR DEFROST WIRING DIAGRAM MOTOR TYPE D – AIR DEFROST	175
FIGURE 10 (A) AIR DEFROST WIRING DIAGRAM MOTOR TYPE V – AIR DEFROST	175
FIGURE 11 DEFROST TERMINATION THERMOSTAT LOCATION FOR CARBON DIOXIDE (R744)	Error! Bookmark not defined.
FIGURE 12 ELECTRIC DEFROST WIRING WITH DEFROST TIMER – Motor C	17
FIGURE 13 ELECTRIC DEFROST WIRING WITH DEFROST TIMER – Motor D	18
FIGURE 14 ELECTRIC DEFROST WIRING WITH DEFROST TIMER – Motor V	18
FIGURE 15 ELECTRICAL DEFROST WIRING 208-230/3/60	19
FIGURE 16 (E) EDL ELECTRICAL DEFROST WIRING 380/460/575/3/60	19
FIGURE 17 (H) HGE (3 PIPE) HOT GAS AND ELECTRICAL DRAIN PAN WIRING	22
FIGURE 18 (G) HGG (3 PIPE) HOT GAS COIL AND HOT GAS DRAIN PAN WIRING	221
FIGURE 19 (P) KGG (2 PIPE) COOL GAS COIL AND ELECTRICAL DRAIN PAN WIRING	222
FIGURE 20 (K) KGG (2 PIPE) COOL GAS COIL AND DRAIN PAN WIRING	222
FIGURE 21 WIRING DRAWING OF EVAPORATOR WITH SYSTEM 450	24
FIGURE 22 KB DRIVE FACTORY INSTALLED JUMPER	224
FIGURE 23 SET UP IN SINGLE COMPRESSOR UNIT (SINGLE COMPRESSOR INTERLOCK)	25
FIGURE 24 DUAL SPEED MOTOR EVAPORATER COIL (SINGLE COMPRESSOR INTERLOCK)	25
FIGURE 25 VARIABLE SPEED MOTOR EVAPORATER COIL (SINGLE COMPRESSOR INTERLOCK)	26
FIGURE 26 REPLACEMENT PART LIST	30

1 RECEIPT OF EQUIPMENT

1.1 INSPECTION

All equipment should be carefully checked for damage or shortages as soon as it is received. Each shipment should be carefully checked against the bill of lading. If any damage or shortage is evident, a notation must be made on the delivery receipt before it is signed, and a claim should then be filed against the freight carrier.

1.2 LOSS OF GAS HOLDING CHARGE

Each unit cooler is leak tested, evacuated to remove moisture and then shipped with a gas holding charge. Absence of this charge may indicate a leak has developed in transit. The system should not be charged with refrigerant until it is verified that there are no leaks, or the source of the leak is located.

2 ASSEMBLY OF COMPONENTS

2.1 SHIPPED LOOSE PARTS- LONG THROW ADAPTERS

Long Throw Adapters shipped loose. They should be mounted on the unit before the unit is installed. The evaporator fan cabinet contains through-bolts with the threaded end pointing out away from the fan cabinet. The bolts have two ½” nuts, flat washers, and a lock washer on them. Remove the outer most nuts, lock washer, and one flat washer. Place Long Throw Adapter on the bolts braced against the remaining flat washer. While holding the adapter with one hand place the flat washers, then the lock washers, and then thread the nuts on the top two bolts to hold the guard and adapter in place. Then place the remaining washers and thread the remaining two nuts on the bottom two bolts. Secure with a wrench.

3 RIGGING INSTRUCTIONS

3.1 RIGGING INSTRUCTIONS

SM/SV unit tends to be a long and heavy object with about 2/3 of the weight contained in the coil element at the rear of the unit. Jobsite requirements will affect the method of moving and lifting the unit into place. Carefully consider the support that is required to lift and move the unit. Under no circumstances should the shipping skid be used for lifting the unit. To ensure that the unit is not bowed or damaged when being lifted into place from above, all leg or hanger points should be used. If the unit is being lifted into place from underneath, a level support directly under all of the shipping legs is required to adequately steady the unit as it is lifted to the hanger rods.

4 UNIT INFORMATION AND DIMENSIONS

4.1 MODELS COVERED

SM Series medium profile unit coolers.

SV Series medium profile unit coolers - low temperature.

The SM and SV series are designed for walk-in coolers with ceiling heights of 12 to 25 feet that require high airflow. SM/SV unit coolers draw air through the coil and discharge it into the room via the unit fans.

The SM/SV series handles medium to low temperature requirements and has three defrost options – air, electric and hot gas. The SV series is designed for low temperatures allowing extra high air discharge velocities. The SV unit coolers are only available with electric defrost.

FIGURE 1: MODEL KEY

SM	A	2	5	E	-	0842	T	C	K	K
----	---	---	---	---	---	------	---	---	---	---

Unit Type

SM - Space Master
SV - High Velocity

DOE Application

D - DOE and NRCan
A - Non-Regulated

Number of Fans

4, 5, 6, 7 FPI

Fin Spacing

4, 5, 6, 7 FPI

Type of Defrost

A - Air Defrost
E - Electric Defrost w/Electric Pan Heat
G - 3 Pipe Hot Gas w/Gas Pan Heat
H - 3 Pipe Hot Gas w/Electric Pan Heat
K - 2 Pipe Kool Gas w/Gas Pan Heat
P - 2 Pipe Kool Gas w/Electric Pan Heat
R - Heat Reclaim

Heater Voltage

K - 208-230/3/60
M - 460/3/60
P - 575/3/60
U - 380/3/50
L - 380/3/60*

Motor Voltage

K - 208-230/3/60
M - 460/3/60
P - 575/3/60
U - 380/3/50
L - 380/3/60*

Motor Type***

C - 3 Phase Motors**
V - Variable Speed EC, 3 Phase
D - Variable Speed EC, 2 Speed Control

Refrigerant

N - Stock Unit****	G - Stock Unit*****
S - R-404A	Q - R-407A T - R-448A
P - R-507A	F - R-407F R - R-449A

B - Glycol / Brine

BTU/H in Hundreds (00)



* Contact application engineering for quoting.
 ** Inverter suitable motor for K, M, P, and U voltages with 3 phase motors.
 *** Available in K, M, U, and L motor voltages. **DOE** and **NRCan** applications with Dual Speed or Variable Speed EC control.
 **** **N Stock Units** are for non-glide or glide refrigerants (consult I/O manual for complete refrigerant listing).
 ***** **G Stock Units** are for glide refrigerants only (consult I/O manual for complete refrigerant listing).

Additional refrigerants are shown in the TABLE classified as Glide and Non-Glide for selection of two speed or variable speed motors to meet DOE/NRCan regulations.

Glide Refrigerants	
Dewpoint to bubble	TD
R-401A	9.8
R-401B	9.4
R-407A	10.5
R-407F	10.6
R-407H	11.4
R-409A	14.8
R-409B	13.5
R-417A	7.6
R-422A	7
R-422D	7
R-438A	10.8
R-448A	10.5
R-449A	9.7

Non-glide refrigerants	
Dewpoint to bubble	TD
R-134a	0
R-22	0
R-402A (HP80)	2.6
R-402B	3.1
R-404A	1
R-408A	0.7
R-410A	0.2
R-502	0
R-507A	0
R-513A	0.1

4.2 UNIT DIMENSIONS

FIGURE 2: UNIT DIMENSIONS

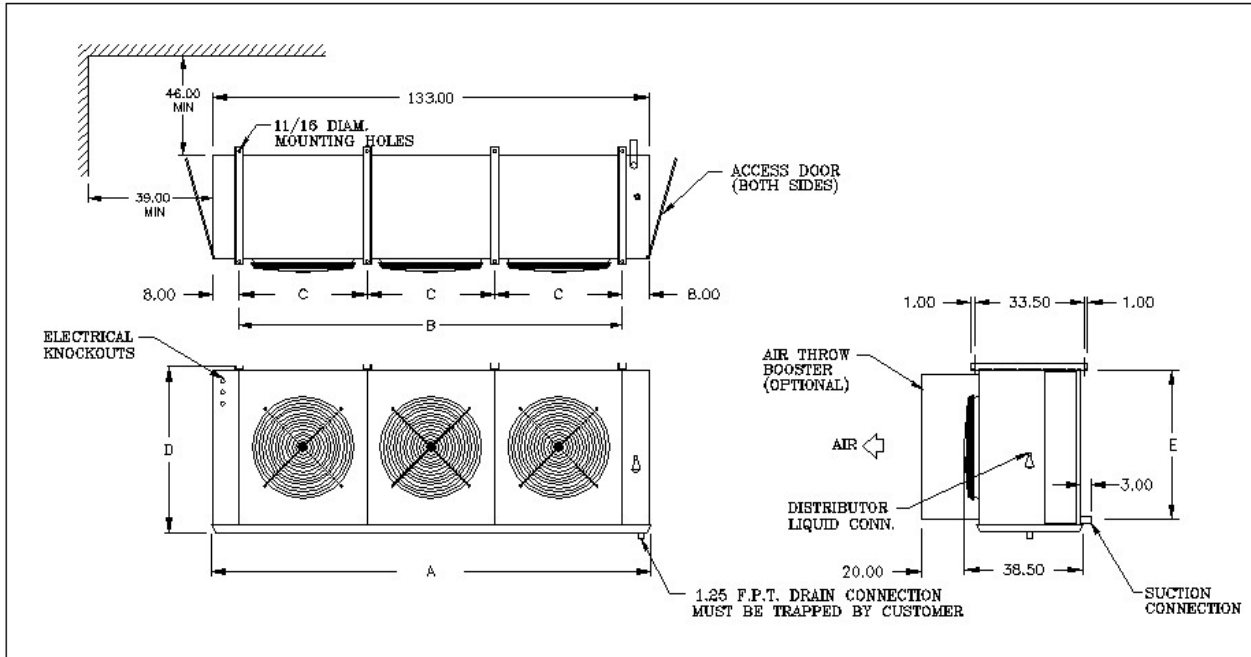

TABLE 1 UNIT DIMENSIONS

Fan Q-ty	A	B	C	D	E
1	77.00	60.00	60.00	40.50	34.00
2	134.25	117.00	58.50	40.50	34.00
3	134.25	117.00	39.00	52.50	46.00
4	173.00	156.00	39.00	52.50	46.00

5 UNIT LOCATION AND MOUNTING

5.1 UNIT LOCATION

Unit coolers must be located to provide good air circulation to all areas of the cooler. The unit cooler should be positioned to blow away from the wall and directed down an aisle rather than into and through shelves. For best performance it is desirable to arrange the air discharge toward the door of the cooler to minimize the entrance of warm moist air when the door is open. Light fixtures, shelving and product boxes must be located so that they do not block the air intake or air discharge from the unit cooler.

IMPORTANT:

The coil face must be located a minimum of 34" for 1, 2 fans and 46" for 3, 4 fans from back side to the wall to assure unrestricted air intake.

5.2 MOUNTING

Install the expansion valve and equalizer connection before hanging the unit cooler.

The unit cooler should be suspended with 1/2" or 5/8" diameter hanger rods. Rods should have double nuts on the top and bottom. Adequate support must be provided to hold the weight of the unit.

The unit must be mounted so that the drain pan end is approximately 1" lower than the bottom of the electrical end of the unit. If mounted to a level ceiling the hanging brackets are providing the slope. Mount to ceiling with u-channels provided. Suspended units must have sufficient clearance above for cleaning the top. Remove shipping legs after installation.

6 PIPING INSTALLATION

6.1 DRAIN LINE

The drain line should be as short and as steeply pitched as possible with a minimum of 1/4" drop per running foot. A drain line trap should be installed to prevent warm moist air from migrating through the drain line. If the temperature surrounding the drain line and trap is below freezing (32°) it must be wrapped with a drain line heater and insulation. Be sure to also wrap the drain pan coupling. The drain line heater must be energized continuously. Be sure to follow the manufacturer's recommendation when installing the drain line heat tape.

FIGURE 3: DRAIN LINE

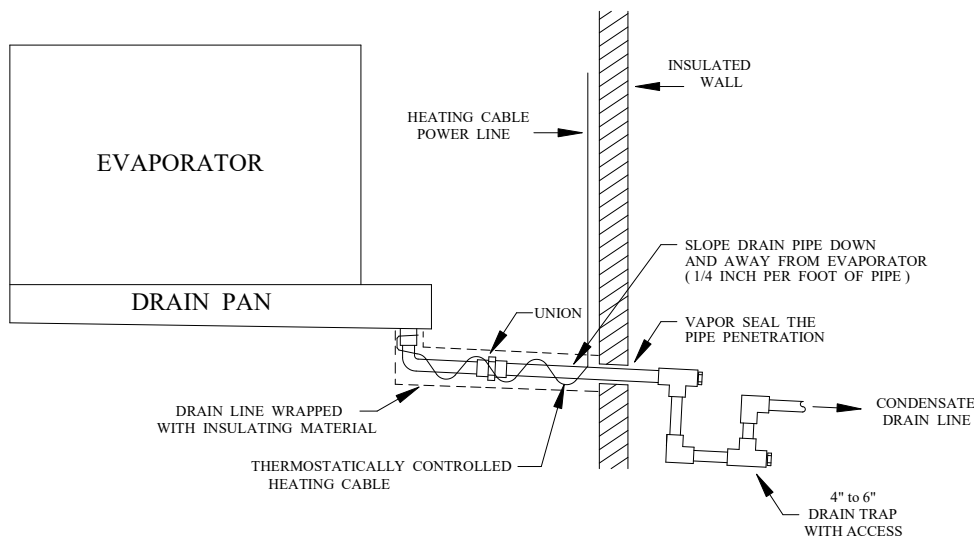

A union at the drain connection in the drain pan is recommended for ease of installation and future servicing. The union should be located as close to the drain pan as possible. Use two wrenches when tightening to prevent the drain fitting from twisting and damaging the unit.

Hangers to avoid damage to the drain pan should support long runs of drain line, i.e. more than a few feet.

FIGURE 4: PIPE JOINING

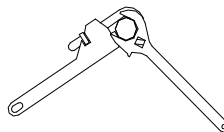

6.2 REFRIGERATION PIPING

System design must conform to all local and national codes, laws and regulations applying to the site of installation. In addition, the safety code for mechanical refrigeration, ASME B31.5, should be followed as a guide to safe installation and operation practice.

Refrigerant line sizes and piping techniques should be obtained from the ASHRAE guide or equivalent reference. Under no circumstances should the refrigerant connection size of the unit be used as the basis for sizing the lines.

The horizontal suction line should slope away from the unit cooler toward the compressor. Vertical suction risers may require a trap at the bottom of the riser for proper oil return.

When connecting multiple unit coolers in series using a common suction line, the branch suction lines must enter the top of the common suction line. The branch lines must be sized for the evaporator capacity and the common suction line to be sized for the total system capacity.

To properly protect and control systems using pumped liquid overfeed R744, the solenoid, isolation, and pressure relief valves shall be arranged as shown in either FIGURE 5 or 6, according to the solenoid valve arrangement. To handle the requirements of liquid R744 high pressure solenoid valves are to be used.

FIGURE 5: MULTIPLE UNIT COOLERS CONTROLLED BY A SINGLE SOLENOID

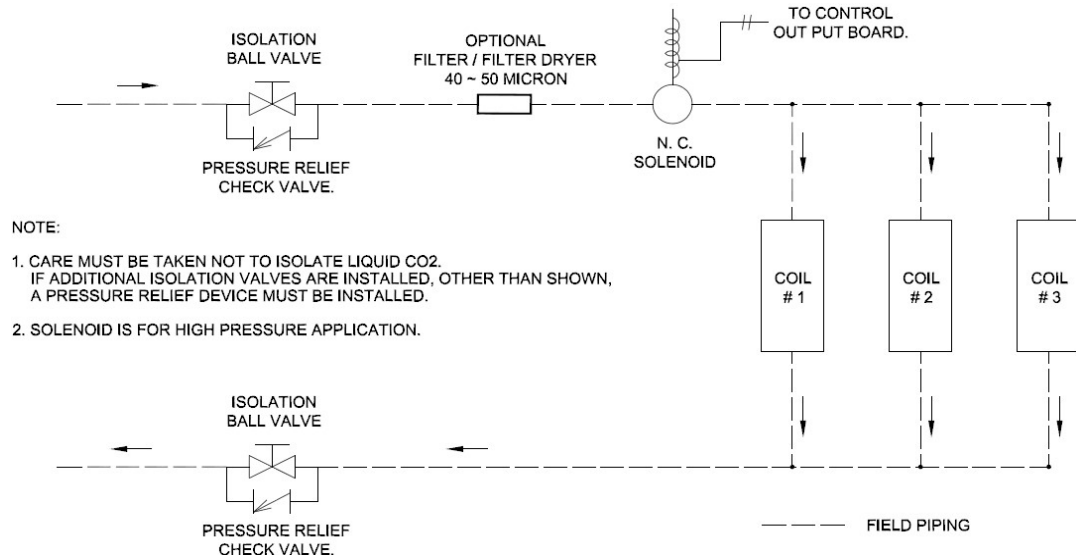
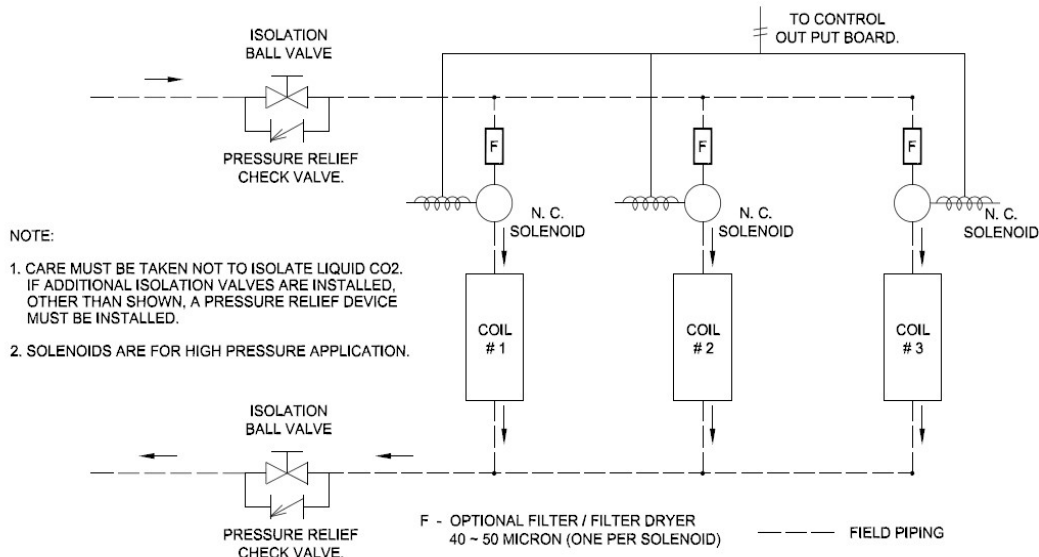

FIGURE 6: MULTIPLE UNIT COOLERS CONTROLLED BY MULTIPLE SOLENOIDS



6.3 EVACUATION AND LEAK TEST

When all refrigeration connections have been completed, the entire system must be tested for leaks and then evacuated. Refer to the instructions provided with your systems condensing unit for information on performing the leak test and evacuation.

6.4 SM GAS DEFROST PIPING

FIGURE 7: GAS DEFROST PIPING DIAGRAMS

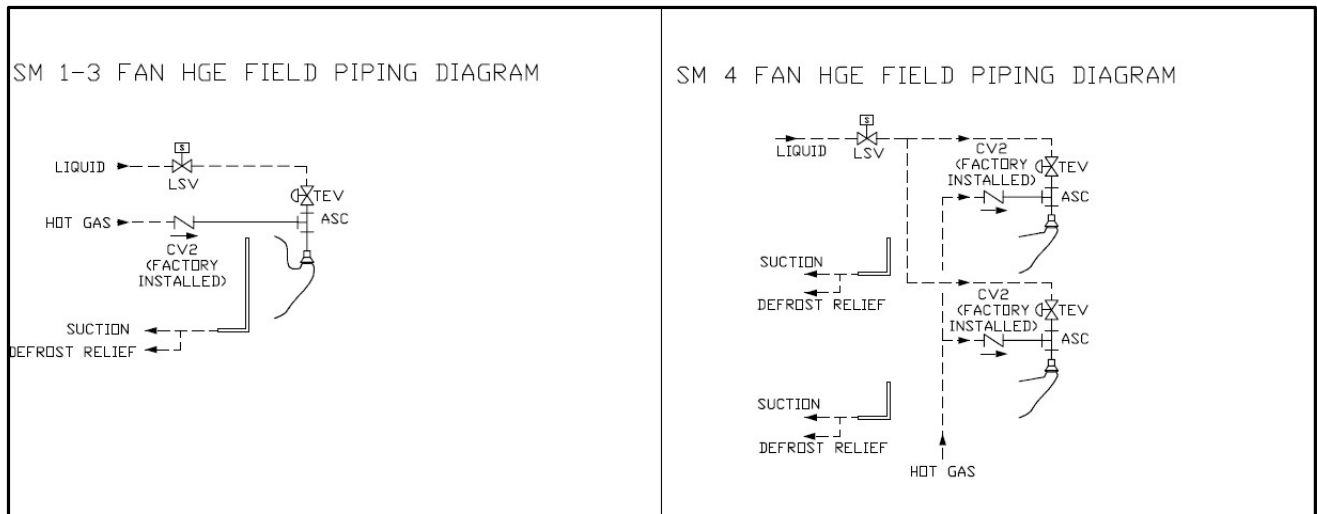

Legend

- | | |
|-----------------------------|---------------------------|
| ———— Piping by Manufacturer | - - - - Piping by Others |
| CV1 Suction Check Valve | CV2 Gas Inlet Check Valve |
| CV3 Relief Check Valve | TEV Expansion Valve |
| ASC Aux. Side Connector | LSV Liquid Solenoid Valve |
- See TABLE 2 for Check Valves Kits.

SM 1-3 FAN HGG FIELD PIPING DIAGRAM

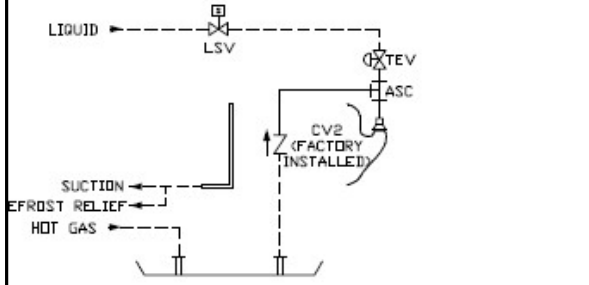

SM 4 FAN HGG FIELD PIPING DIAGRAM

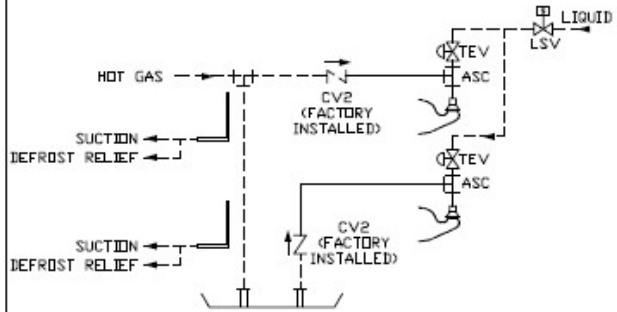

SM 1-3 FAN KG/KGE FIELD PIPING DIAGRAM

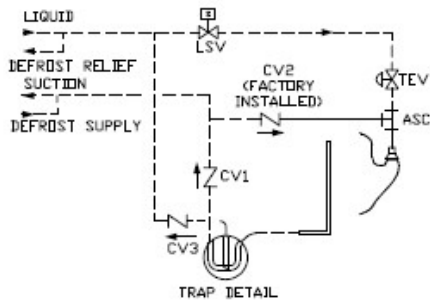

SM 4 FAN KG/KGE FIELD PIPING DIAGRAM

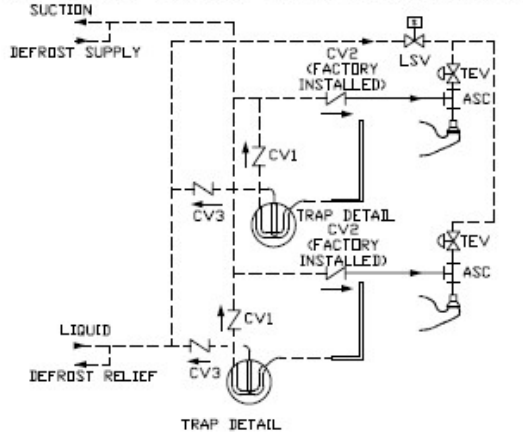

SM 1-3 FAN KGG FIELD PIPING DIAGRAM

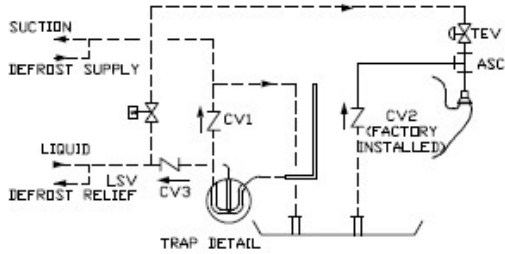

SM 4 FAN KGG FIELD PIPING DIAGRAM

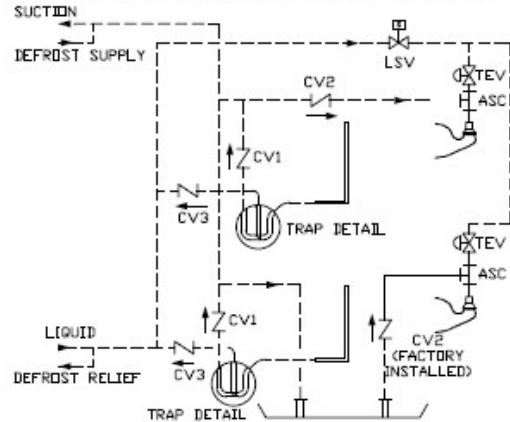

Legend

- | | |
|-----------------------------|---------------------------|
| ———— Piping by Manufacturer | ----- Piping by Others |
| CV1 Suction Check Valve | CV2 Gas Inlet Check Valve |
| CV3 Relief Check Valve | TEV Expansion Valve |
| ASC Aux. Side Connector | LSV Liquid Solenoid Valve |

See TABLE 2 for Check Valves Kits.

TABLE 2: CHECK VALVES KITS

Model SM	(K) KGG, (P) KGE Check Valves Kit	Suct line CV diam	Gas inlet CV diam	Gas relief CV diam	(G) HGG, (H) HGE Check Valves Kit	Gas inlet CV diam
384	CE269377	1.625	0.500	0.500	CE269381	0.500
426		1.625	0.500	0.500		0.500
440		1.625	0.500	0.500		0.500
501	CE269378	2.125	0.875	0.875	CE269382	0.875
556		2.125	0.875	0.875		0.875
574		2.125	0.875	0.875		0.875
759		2.125	0.875	0.875		0.875
842		2.125	0.875	0.875		0.875
869		2.125	0.875	0.875		0.875
989	CE269379	2.625	0.875	0.875	CE269382	0.875
1070		2.625	0.875	0.875		0.875
1097		2.625	0.875	0.875		0.875
1132		2.625	0.875	0.875		0.875
1186		2.625	0.875	0.875		0.875
1225	CE269380	2.625	1.125	1.125	CE269383	1.125
1393		2.625	1.125	1.125		1.125
1544		2.625	1.125	1.125		1.125
1594		2.625	1.125	1.125		1.125
1465	2 CE269378	2.125	0.875	0.875	2 CE269382	0.875
1523		2.125	0.875	0.875		0.875
1754		2.125	0.875	0.875		0.875
1769		2.125	0.875	0.875		0.875
1985	2 CE269379	2.625	0.875	0.875		0.875
2307		2.625	0.875	0.875		0.875

6.5 REFRIGERANT DISTRIBUTOR NOZZLES

Direct expansion unit coolers are piped using a refrigerant distributor with a **changeable nozzle** design to equally distribute refrigerant to each circuit of the evaporator coil. Distributor nozzles are installed at the factory.

The nozzles provided with the unit have been selected for design conditions of 10°F T.D. and 95°F liquid refrigerant at the expansion valve inlet. If the unit will be operated at conditions that are substantially different from these conditions, it may be necessary to select a different size nozzle. Contact the factory for advice.

The nozzle must be installed in the distributor or the auxiliary side connector before installing the expansion valve. There are nozzle identification numbers stamped on one side of the nozzle. Be sure to insert the nozzle into the distributor with these numbers visible in case identification is required later. The nozzle is held in place by a retainer ring that is easily inserted or removed with a pair of needle nose pliers.

TABLE 3: DISTRIBUTOR NOZZLE CAPACITIES – TONS OF REFRIGERANT

DISTRIBUTOR NOZZLE NUMBER	R404A					R407A				
	EVAPORATOR TEMPERATURE (°F)									
	40°	20°	0°	-20°	-40°	40°	20°	0°	-20°	-40°
1/9	0.09	0.07	0.05	0.04	0.04	0.11	0.08	0.07	0.06	0.05
1/6	0.14	0.11	0.08	0.07	0.05	0.17	0.13	0.1	0.09	0.07
1/4	0.23	0.17	0.13	0.11	0.09	0.27	0.21	0.17	0.14	0.12
1/3	0.3	0.23	0.18	0.14	0.11	0.35	0.27	0.22	0.18	0.15
1/2	0.41	0.31	0.24	0.19	0.16	0.48	0.38	0.3	0.25	0.21
3/4	0.62	0.47	0.37	0.29	0.24	0.72	0.57	0.46	0.38	0.32
1	0.83	0.63	0.49	0.39	0.32	0.97	0.76	0.61	0.5	0.43
1 1/2	1.2	0.92	0.71	0.57	0.46	1.41	1.1	0.89	0.73	0.62
2	1.65	1.26	0.98	0.78	0.64	1.94	1.51	1.22	1	0.85
2 1/2	2.06	1.57	1.22	0.97	0.79	2.41	1.88	1.52	1.25	1.06
3	2.47	1.88	1.47	1.17	0.95	2.9	2.26	1.82	1.5	1.28
4	3.31	2.52	1.96	1.56	1.27	3.88	3.03	2.43	2.01	1.71
5	4.08	3.11	2.42	1.93	1.57	4.78	3.73	3	2.48	2.11
6	4.89	3.72	2.91	2.31	1.88	5.73	4.48	3.6	2.98	2.53
8	5.89	4.49	3.5	2.79	2.27	6.91	5.39	4.34	3.58	3.05
10	6.6	5.03	3.92	3.12	2.54	7.74	6.05	4.86	4.02	3.42
12	8.16	6.21	4.84	3.86	3.14	9.56	7.47	6	4.96	4.22
15	10.1	7.7	6.01	4.78	3.89	11.9	9.26	7.45	6.15	5.23
17	11.3	8.61	6.72	5.35	4.35	13.3	10.4	8.33	6.88	5.85
20	13.6	10.4	8.1	6.45	5.24	16	12.5	10	8.29	7.05
25	17.1	13.1	10.2	8.11	6.6	20.1	15.7	12.6	10.4	8.87
30	19.6	14.9	11.6	9.27	7.54	23	17.9	14.4	11.9	10.1
35	23.6	17.9	14	11.1	9.07	27.6	21.6	17.3	14.3	12.2
40	26.4	20.1	15.7	12.5	10.2	31	24.2	19.5	16.1	13.7
50	34.3	26.1	20.4	16.2	13.2	40.2	31.4	25.2	20.9	17.7

DISTRIBUTOR NOZZLE NUMBER	R507					R448A/R449A				
	EVAPORATOR TEMPERATURE (°F)									
	40°	20°	0°	-20°	-40°	40°	20°	0°	-20°	-40°
1/9	0.09	0.07	0.05	0.04	0.03	0.08	0.06	0.05	0.04	0.03
1/6	0.14	0.11	0.08	0.07	0.05	0.12	0.09	0.07	0.06	0.05
1/4	0.23	0.17	0.13	0.11	0.09	0.19	0.15	0.12	0.09	0.08
1/3	0.29	0.22	0.17	0.14	0.11	0.25	0.20	0.15	0.12	0.10
1/2	0.41	0.31	0.24	0.19	0.16	0.35	0.27	0.21	0.17	0.14
3/4	0.61	0.47	0.36	0.29	0.23	0.53	0.41	0.32	0.26	0.21
1	0.82	0.62	0.49	0.39	0.31	0.70	0.54	0.43	0.35	0.29
1 1/2	1.2	0.91	0.71	0.56	0.46	1.02	0.79	0.63	0.50	0.42
2	1.64	1.25	0.97	0.77	0.62	1.40	1.09	0.86	0.69	0.57
2 1/2	2.05	1.56	1.21	0.96	0.78	1.75	1.35	1.07	0.86	0.71
3	2.46	1.87	1.45	1.15	0.93	2.10	1.63	1.28	1.04	0.86
4	3.29	2.5	1.94	1.54	1.25	2.81	2.18	1.72	1.39	1.15
5	4.06	3.08	2.4	1.9	1.54	3.47	2.68	2.12	1.71	1.41
6	4.86	3.69	2.87	2.28	1.85	4.16	3.22	2.54	2.05	1.70
8	5.86	4.45	3.46	2.75	2.23	5.01	3.88	3.06	2.47	2.04
10	6.57	4.99	3.88	3.08	2.5	5.62	4.34	3.43	2.77	2.29
12	8.11	6.16	4.79	3.8	3.08	6.94	5.37	4.24	3.42	2.83
15	10.1	7.64	5.94	4.72	3.83	8.60	6.65	5.26	4.24	3.51
17	11.2	8.54	6.64	5.27	4.28	9.62	7.44	5.88	4.74	3.92
20	13.6	10.3	8.01	6.36	5.16	11.60	8.97	7.08	5.71	4.72
25	17.1	12.9	10.1	8	6.48	14.60	11.30	8.91	7.19	5.94
30	19.5	14.8	11.5	9.13	7.41	16.70	12.90	10.20	8.21	6.79
35	23.4	17.8	13.8	11	8.91	20.00	15.50	12.20	9.88	8.17
40	26.3	20	15.5	12.3	9.99	22.50	17.40	13.70	11.10	9.16
50	34.1	25.9	20.1	16	13	29.20	22.50	17.80	14.40	11.90

6.6 EXPANSION VALVE

Before mounting the unit, install the expansion valve and connect the equalizer tube. The expansion valve should be installed directly to the distributor body or as close as possible with no elbows or bends. Locate the expansion valve bulb on a horizontal length of suction line as close to the suction header as possible. Position the bulb in a 3, 4 or 8, 9 o'clock position (do not position on the bottom side of the pipe). Clamp the bulb down flush and tight against the pipe and insulate. Never locate the bulb in a trap or downstream from a trap.

Expansion valves are adjusted at the factory prior to shipment. The setting will be correct for many applications, but in other applications adjustments may be needed. It is important that the operation of the expansion valve be checked after the system has balanced out at the desired room temperature. If the coil is being starved it is necessary to reduce the superheat setting of the valve by turning the adjusting stem counter-clockwise. If the superheat is too low, it is necessary to increase the superheat setting of the valve by turning the adjusting stem clockwise. It is recommended that for a 10°F to 12°F T.D. system, the valve should be adjusted to maintain 5°F to 6°F superheat.

7 ELECTRICAL

7.1 FIELD WIRING

Field wiring should comply with NEC and local codes. The power supply voltage, phase and frequency must match what is shown on the unit cooler data plate.

The field-wiring compartment is constructed as part of the unit cooler enclosure. The wiring diagram for each unit is located on the inside of the electrical panel door. Wiring connections are made at the terminal block(s) provided inside the unit on the end opposite the refrigerant connections. The unit must be grounded. Refer to TABLE's 4 through 6 for motor and heater electrical information.

For units using Carbon Dioxide (R744) the defrost termination thermostat is to be located on the topmost inlet tube from the inlet header as shown in FIGURE 11.

7.2 ELECTRICAL DATA

TABLE 4: SM MOTOR ELECTRICAL DATA (AMPS)

FAN Q-ty	Motor Type C					Motor Type V and D	
	230/3/60	380/3/60	380/3/50	460/3/60	575/3/60	230/3/60	460/3/60
1	4.8	2.3	2.3	2.4	1.8	5.4	3.0
2	9.6	4.6	4.6	4.8	3.6	10.8	6.0
3	14.4	6.9	6.9	7.2	5.4	16.2	9.0
4	19.2	9.2	9.2	9.6	7.2	21.6	12.0

TABLE 5: SV MOTOR ELECTRICAL DATA (AMPS)

FAN Q-ty	Motor Type C					Motor Type V and D	
	230/3/60	380/3/60	380/3/50	460/3/60	575/3/60	230/3/60	460/3/60
1	5.4	2.5	2.1	2.5	2.2	5.4	3.0
2	10.8	5.0	4.2	5.0	4.4	10.8	6.0
3	16.2	7.5	6.3	7.5	6.6	16.2	9.0
4	21.6	10.0	8.4	10.0	8.8	21.6	12.0

TABLE 6: SM (E) EDL HEATERS ELECTRICAL DATA and SM (P) KGE & (H) HGE HEATERS ELECTRICAL DATA

MODEL	ELECTRICAL DEFROST UNIT (E)						ELECTRICAL DEFROST PAN (H,P)				
	AMP			kW	AMP		kW	AMP			kW
	230/3	460/3	575/3		380/3/60	380/3/50		230/3	460/3	575/3	
SM*14()-384	34.7	17.3	13.9	13.8	19.8	19.8	13.0	6.41	3.20	2.56	2.60
SM*15()-426	34.7	17.3	13.9	13.8	19.8	19.8	13.0	6.41	3.20	2.56	2.60
SM*16()-440	34.7	17.3	13.9	13.8	19.8	19.8	13.0	6.41	3.20	2.56	2.60
SM*14()-501	34.7	17.3	13.9	13.8	19.8	19.8	13.0	6.41	3.20	2.56	2.60
SM*15()-556	34.7	17.3	13.9	13.8	19.8	19.8	13.0	6.41	3.20	2.56	2.60
SM*16()-574	34.7	17.3	13.9	13.8	19.8	19.8	13.0	6.41	3.20	2.56	2.60
SV*14()-442,550	34.7	17.3	13.9	13.8	19.8	19.8	13.0				
SV*15()-468,611	34.7	17.3	13.9	13.8	19.8	19.8	13.0				
SV*16()-664,684	34.7	17.3	13.9	13.8	19.8	19.8	13.0				

MODEL	ELECTRICAL DEFROST UNIT (E)						ELECTRICAL DEFROST PAN (H,P)					
	AMP			kW			kW	AMP			kW	
	230/3	460/3	575/3		380/3/60	380/3/50		230/3	460/3	575/3		
	circ#1	circ#2										
SM*24()-795,989	42.2	21.9	32.0	25.6	25.5	36.6	36.6	24.1	11.31	5.65	4.52	4.5
SM*25()-842,1097	42.2	21.9	32.0	25.6	25.5	36.6	36.6	24.1	11.31	5.65	4.52	4.5
SM*26()-896,1132	42.2	21.9	32.0	25.6	25.5	36.6	36.6	24.1	11.31	5.65	4.52	4.5
SV*24()-834,1088	42.2	21.9	32.0	25.6	25.5	36.6	36.6	24.1				
SV*25()-926,1206	42.2	21.9	32.0	25.6	25.5	36.6	36.6	24.1				
SV*26()-1005,1311	42.2	21.9	32.0	25.6	25.5	36.6	36.6	24.1				

MODEL	ELECTRICAL DEFROST UNIT (E)						ELECTRICAL DEFROST PAN (H,P)					
	AMP			kW			kW	AMP			kW	
	230/3	460/3	575/3		380/3/60	380/3/50		230/3	460/3	575/3		
	circ#1	circ#2										
SM*34()-1070	42.2	32.5	37.4	29.9	29.7	43.0	43.0	28.3	11.31	5.65	4.52	4.5
SM*35()-1186	42.2	32.5	37.4	29.9	29.7	43.0	43.0	28.3	11.31	5.65	4.52	4.5
SM*36()-1225	42.2	32.5	37.4	29.9	29.7	43.0	43.0	28.3	11.31	5.65	4.52	4.5
SM*34()-1393	42.2	32.5	37.4	29.9	29.7	43.0	43.0	28.3				
SM*35()-1544	42.2	32.5	37.4	29.9	29.7	43.0	43.0	28.3				
SM*36()-1594	42.2	32.5	37.4	29.9	29.7	43.0	43.0	28.3				
SV*34()-1177,1530	42.2	32.5	37.4	29.9	29.7	43.0	43.0	28.3				
SV*35()-1304,1698	42.2	32.5	37.4	29.9	29.7	43.0	43.0	28.3				
SV*36()-1418,1843	42.2	32.5	37.4	29.9	29.7	43.0	43.0	28.3				

MODEL	ELECTRICAL DEFROST UNIT (E)						ELECTRICAL DEFROST PAN (H,P)						
	AMP			kW			kW	AMP			kW		
	230/3	460/3	575/3		380/3/60	380/3/50		230/3	460/3	575/3			
	circ#1	circ#2	circ#3			circ#1	circ#2						
SM*44()-1465	40.71	40.71	14.3	47.8	38.3	38.1	32.8	22.3	36.3	14.30	7.20	3.90	5.7
SM*45()-1523	40.71	40.71	14.3	47.8	38.3	38.1	32.8	22.3	36.3	14.30	7.20	3.90	5.7
SM*46()-1754	40.71	40.71	14.3	47.8	38.3	38.1	32.8	22.3	36.3	14.30	7.20	3.90	5.7
SM*44()-1769	40.71	40.71	14.3	47.8	38.3	38.1	32.8	22.3	36.3	14.30	7.20	3.90	5.7
SM*45()-1985	40.71	40.71	14.3	47.8	38.3	38.1	32.8	22.3	36.3	14.30	7.20	3.90	5.7
SM*46()-2307	40.71	40.71	14.3	47.8	38.3	38.1	32.8	22.3	36.3	14.30	7.20	3.90	5.7
SV*44()-1699,2052	40.71	40.71	14.3	47.8	38.3	38.1	32.8	22.3	36.3				
SV*45()-1883,2274	40.71	40.71	14.3	47.8	38.3	38.1	32.8	22.3	36.3				
SV*46()-2047,2472	40.71	40.71	14.3	47.8	38.3	38.1	32.8	22.3	36.3				
SM*44()-1532,1829,2015													
SM*46()-1846,2204,2428													
SM*47()-1920,2281,2581													

7.3 AIR DEFROST SEQUENCE OF OPERATION

SEQUENCE OF OPERATION

1. The unit cooler fan motors are energized, and the fans operate continually.
2. The room thermostat calls for cooling. The liquid solenoid valve opens allowing liquid to flow to the unit cooler. The suction pressures rises and starts the compressor.
3. When the room temperature is satisfied the thermostat opens and closes the liquid solenoid. The compressor continues to run until the suction pressure reaches the low-pressure cutout setting and shuts off the compressor.
4. The fan circulates air over the coil and frost melts.

For air defrost to work properly the compressor run time should not exceed 40 minutes per hour.

(A) AIR DEFROST WIRING DIAGRAM

FIGURE 8: - MOTOR TYPE C – AIR DEFROST

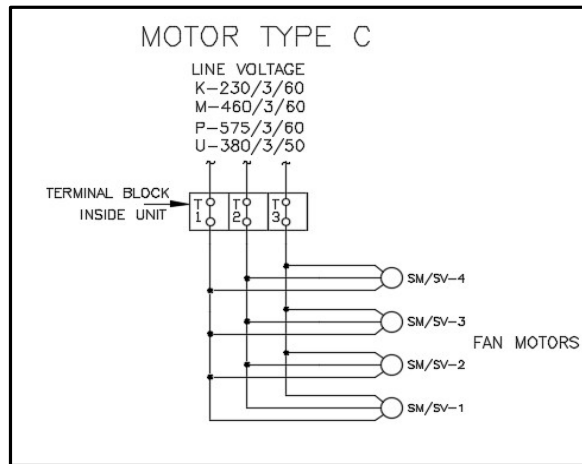

FIGURE 9: - MOTOR TYPE D – AIR DEFROST

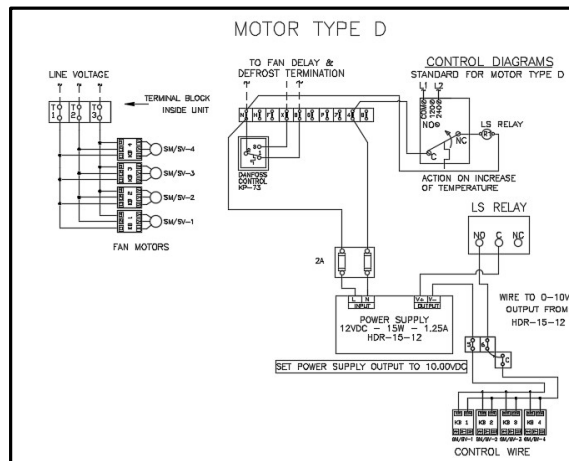
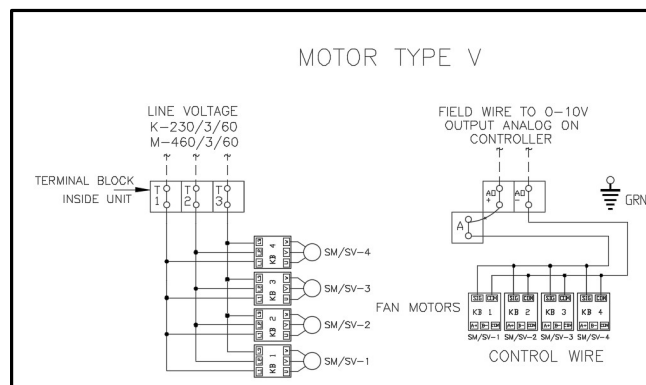

FIGURE 10: - MOTOR TYPE V – AIR DEFROST



7.4 *ELECTRIC DEFROST SEQUENCE OF OPERATION*

The electric defrost cycle is time clock initiated and temperature terminated with a timer and or high temperature over-ride. For systems with multiple unit coolers and a single defrost time clock the defrost termination thermostat must be wired in series. Reference FIGURE's 12 through 16, for electric defrost wiring diagrams.

SEQUENCE OF OPERATION

STEP A: Normal Refrigeration Cycle

1. Power is supplied to terminals "N" and "4" on the defrost timer.
2. The heater safety and fan delay thermostat are closed, the defrost termination thermostat is off and the defrost heaters are off.
3. The unit cooler fan motors are energized, and the fans operate continually.
4. The systems compressor operates in accordance with the demand of the room thermostat.
5. Frost slowly builds up on the evaporator fins.

STEP B: Defrost Cycle

The timer starts defrosting of the evaporator coil at a predetermined interval. A typical setting would be two defrost periods per 24-hour day. Systems using Carbon Dioxide (R744) should defrost at least twice per day.

1. Upon initiation of the defrost cycle, the timer mechanically disconnects power to terminal "4" thus closing the liquid line solenoid valve and shutting off the fan motors. Simultaneously power is connected to terminal "3" which allows current to flow to the defrost heaters.
2. The heaters, embedded in slots in the coil face, give up heat directly to the evaporator fins. This heat raises the coil temperature to 32°F causing the frost to melt.
3. As the frost melts it drops into the drain pan and flows down the drain.
4. When the frost has completely melted from the coil the temperature of the coil will start to rise above 32°F.
5. When the coil reaches the temperature setting of the defrost termination thermostat (75°F for fixed Klixon), the thermostat closes which allows current to flow to terminal "X" on the timer which energizes the switching solenoid in the timer. The timer disconnects power to terminal "3" thus turning off the defrost heaters. At the same, instant power is connected to terminal "4" of the timer.
6. Because there is power at terminal "4" the liquid line solenoid opens and the compressor restarts.
7. The evaporator fan motor(s) remain off because the fan delay thermostat is still open. This prevents warm air from being blown into the refrigerated area.
8. The evaporator coil cools down approaching operating temperature.
9. When the coil temperature reaches 25°F (approximately 2 to 3 minutes after defrost termination) the fan delay thermostat closes, thus allowing the fan motors to restart. The unit is now back in operation.
10. The heater safety thermostat will only open if the defrost termination thermostat fails to close at it's set temperature. The heater safety thermostat is set to open at 80°F. The timer also has a fail-safe (inner dial) timeout; the recommended setting is for 30 minutes.

NOTE: On systems where the room temperature is above +25°F the fan delay thermostat may not close for an extended period of time. If the fan delay time is too long, it is permissible to install a jumper wire between terminals "F" and "B" at the unit cooler. This allows the fans to turn on immediately after the defrost period.

FIGURE 11: DEFROST TERMINATION THERMOSTAT LOCATION FOR CARBON DIOXIDE (R744)

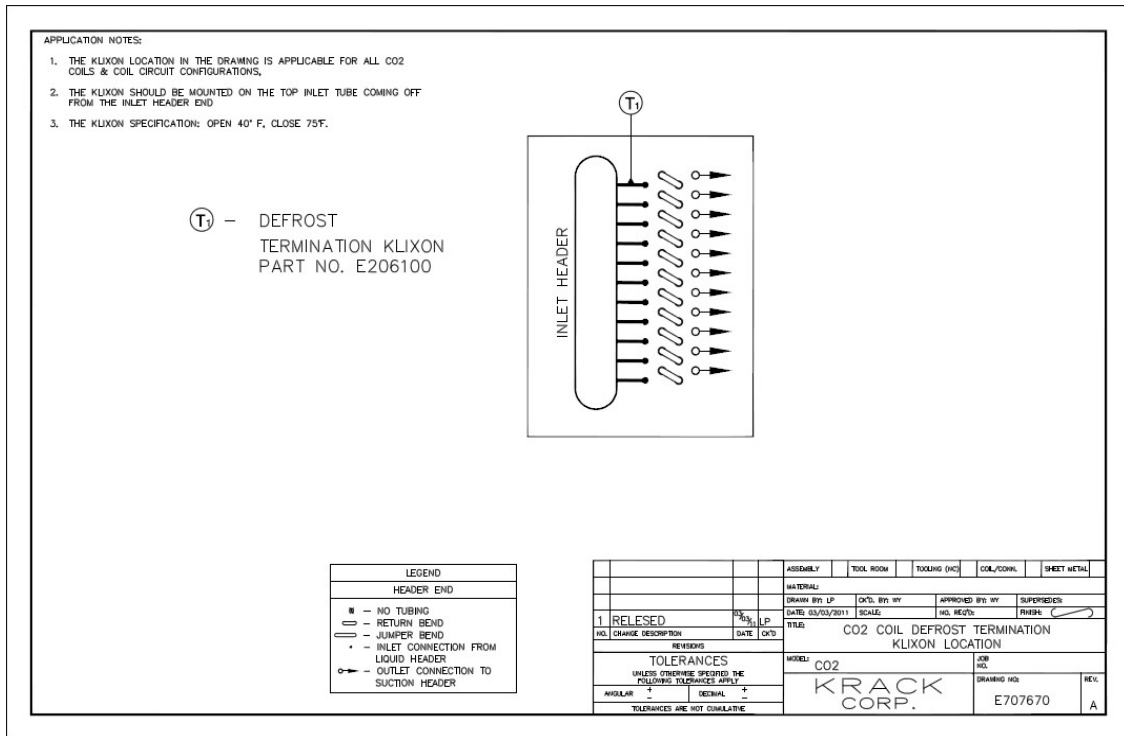

ELECTRIC DEFROST WIRING WITH DEFROST TIMER

FIGURE 9: ELECTRIC DEFROST WIRING WITH DEFROST TIMER – MOTOR C

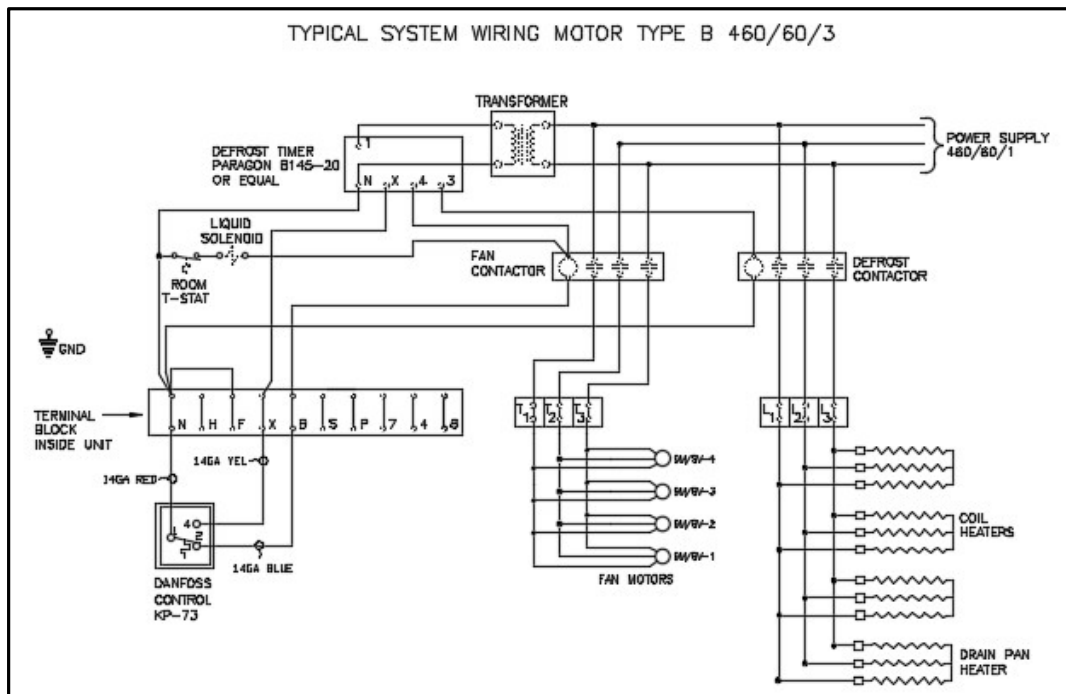

FIGURE 13: ELECTRIC DEFROST WIRING WITH DEFROST TIMER – MOTOR D

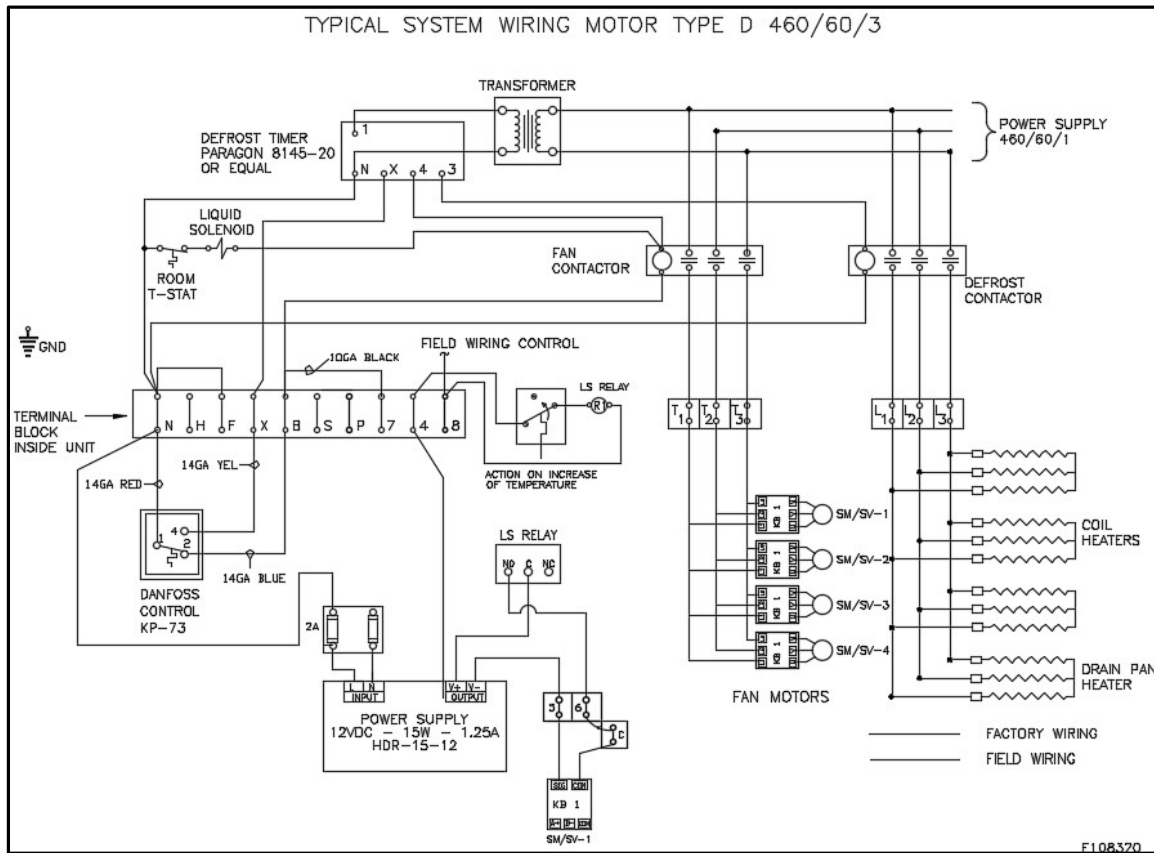

FIGURE 14: ELECTRIC DEFROST WIRING WITH DEFROST TIMER – MOTOR V

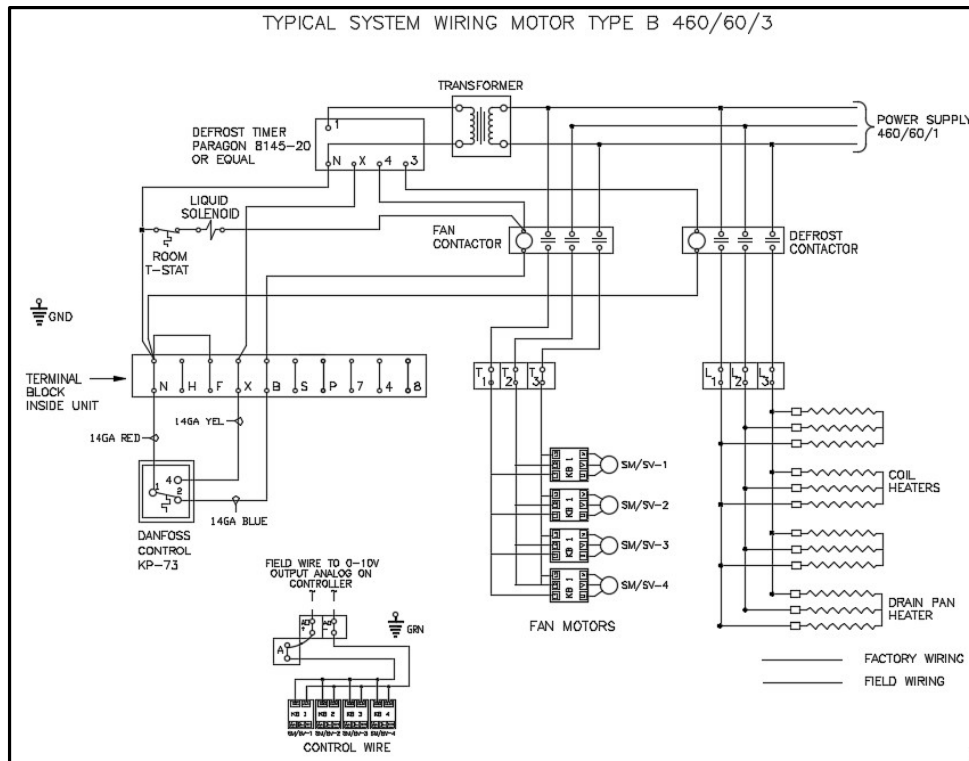

FIGURE 10: ELECTRICAL DEFROST WIRING 208-230/3/60

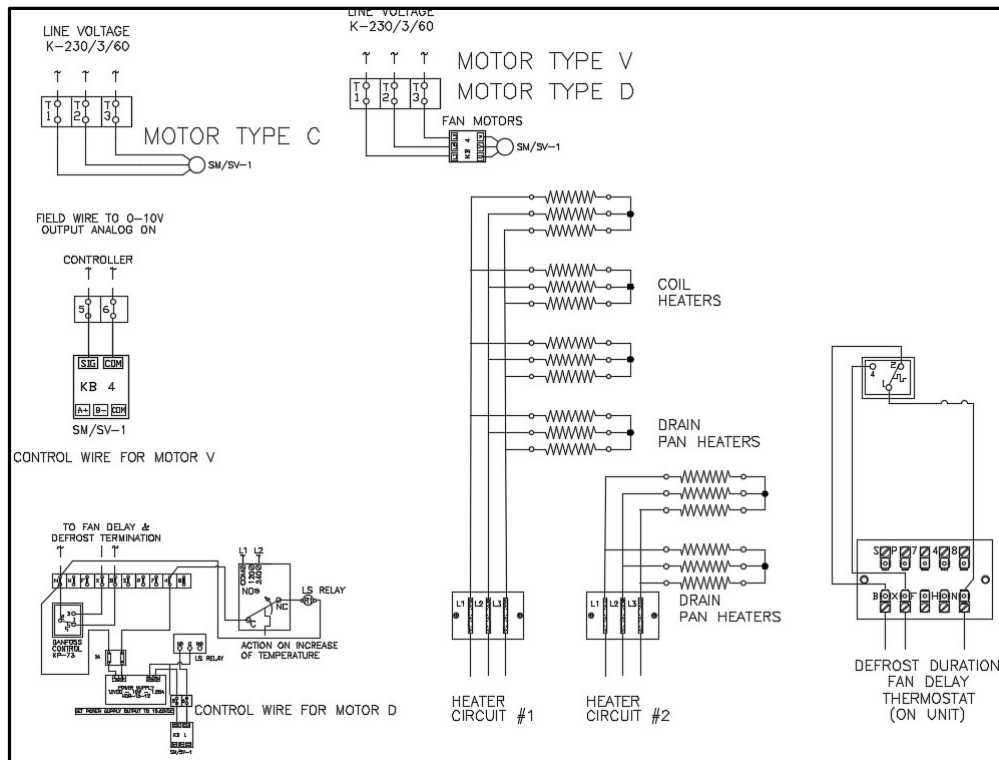
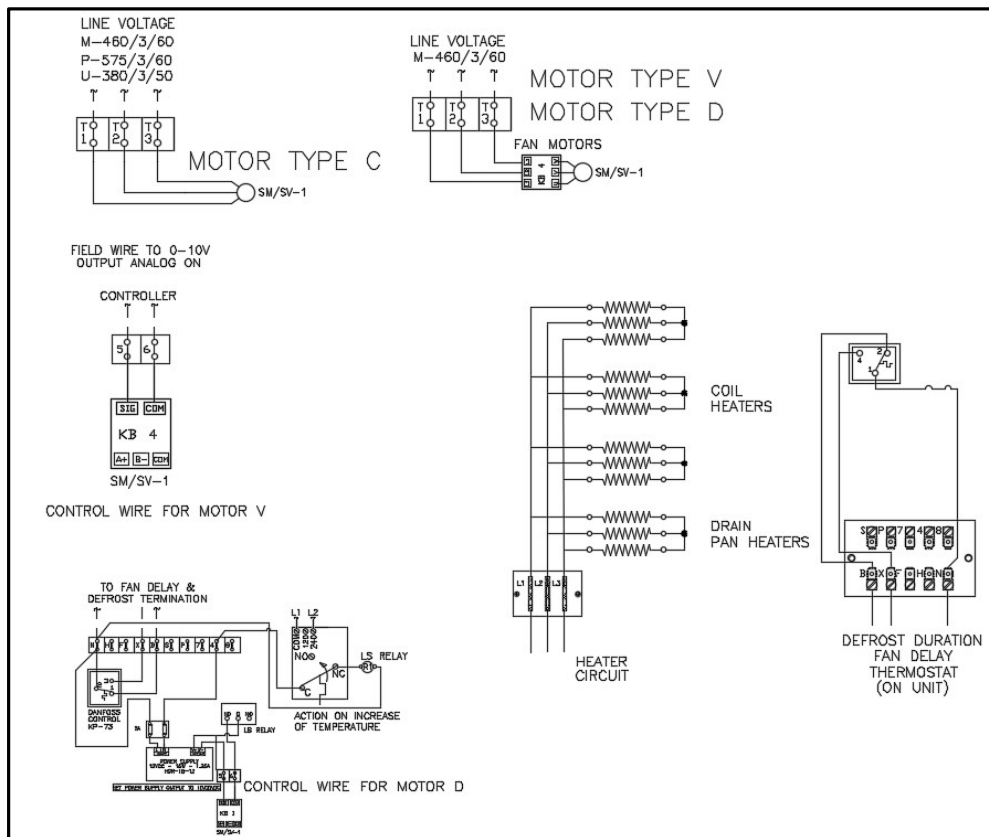

FIGURE 16: (E) EDL ELECTRICAL DEFROST WIRING 380/460/575/3/60



7.5 GAS DEFROST SEQUENCE OF OPERATION

The gas defrost cycle is time is field controller initiated and terminated

(H) HGE/(G) HGG THREE PIPE HOT GAS DEFROST

Three pipe hot gas defrost systems distribute compressor discharge gas through a separate hot gas line, controlled by a solenoid valve, through a check valve to the refrigerant distributor auxiliary side connection. Defrost condensate and gas vapor is evaporated in a re-evaporator outside the MS unit prior to returning to the compressor through the suction line.

(P) KGE/(K) KGG REVERSE CYCLE (2 PIPE) HOT GAS DEFROST

Reverse cycle (2 pipe) defrost systems distribute compressor discharge gas through the suction line during defrost. Defrost condensate flows through the refrigerant distributor auxiliary side connection and a check valve, bypassing the expansion valve and the liquid line solenoid valve into the liquid line, which is reduced in pressure.

SEQUENCE OF OPERATION - GAS DEFROST WITH ELECTRIC DRAIN PAN HEATER

Step A – Power is supplied to the unit cooler continuously.

Step B – In Case of H defrost hot gas is supplied to the unit via liquid line and in Case of P defrost Kool Cas is supplied to the suction line. A factory mounted thermostat (KP73) senses a rise in the coil temperature. The SPDT control turns off the fan motors. If the unit has a drain pan heater, the other portion of the SPDT control is now closed and the drain pan heater is energized.

Step C – When the defrost is complete, the hot gas supply is stopped. The liquid line solenoid is energized, and the coil temperature begins to fall.

Step D – The factory mounted thermostat senses the drop in coil temperature. The SPDT thermostat opens the circuit to the drain pan heater (when supplied) and closes the circuit to the fan motors.

Recommended (SPDT) fan delay/drain pan heater thermostat settings:

Room	Range	Differential
0°F to +35°F	45°F	15°F
Below 0°F	20°F	10°F

(Note: Fan delay set point = Range – Differential)

A separate SPDT thermostat (KP73) is provided in the coil which can provide a digital defrost termination input.

SEQUENCE OF OPERATION - GAS DEFROST WITH GAS DRAIN PAN HEATER

Step A – Power is supplied to the unit cooler continuously.

Step B – In Case of H defrost hot gas is supplied to the unit via liquid line and in Case of P defrost Kool Cas is supplied to the suction line. A factory mounted thermostat (Klixon) senses a rise in the coil temperature. The SPDT control turns off the fan motors.

Step C – When the defrost is complete, the hot gas supply is stopped. The liquid line solenoid is energized, and the coil temperature begins to fall.

Step D – The factory mounted thermostat senses the drop in coil temperature and closes the circuit to the fan motors.

A separate SPDT thermostat (KP73) is provided in the coil which can provide a digital defrost termination input.

FIGURE 17:11 (H) HGE (3 PIPE) HOT GAS AND ELECTRICAL DRAIN PAN WIRING

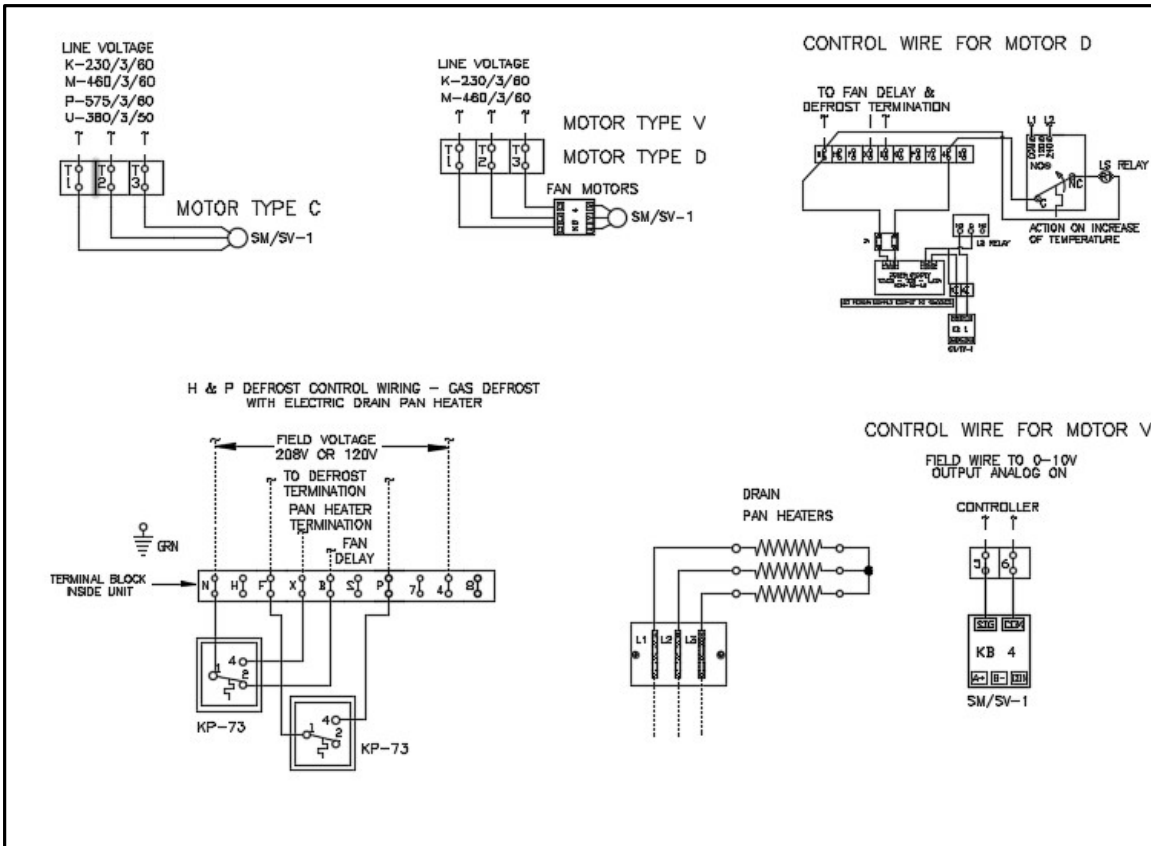

FIGURE 12: (G) HGG (3 PIPE) HOT GAS COIL AND HOT GAS DRAIN PAN WIRING

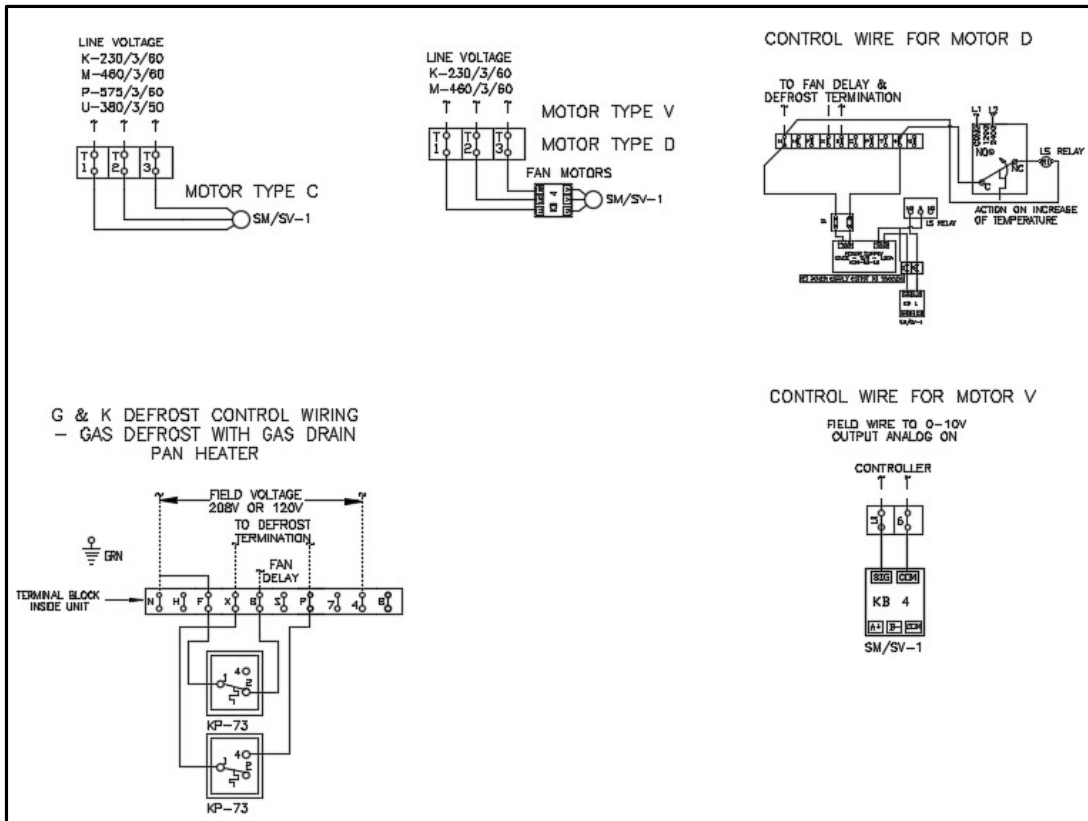

FIGURE 13: (P) KGE (2 PIPE) KOOL GAS COIL AND ELECTRICAL DRAIN PAN WIRING

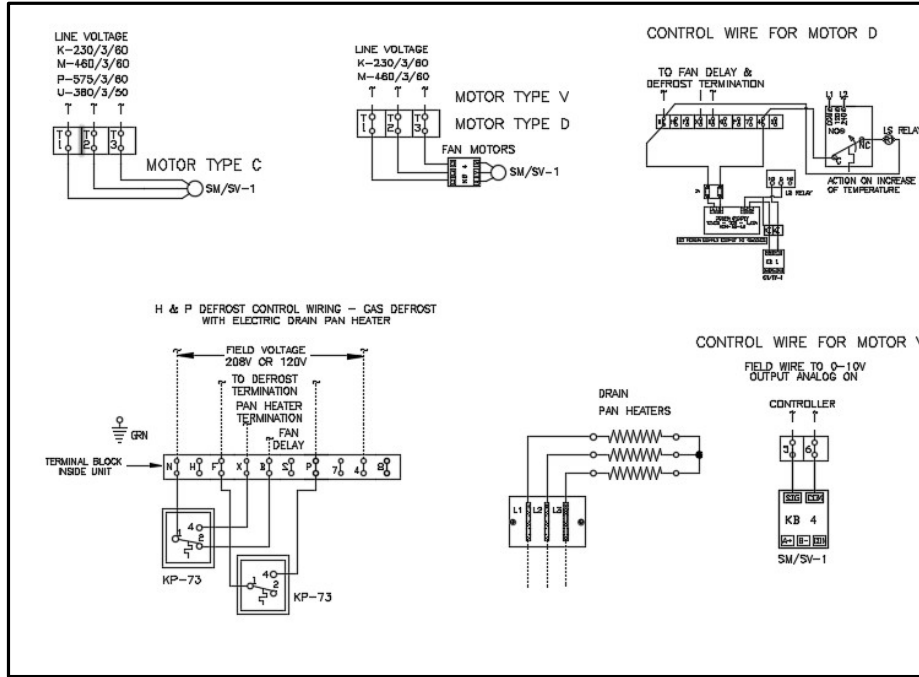
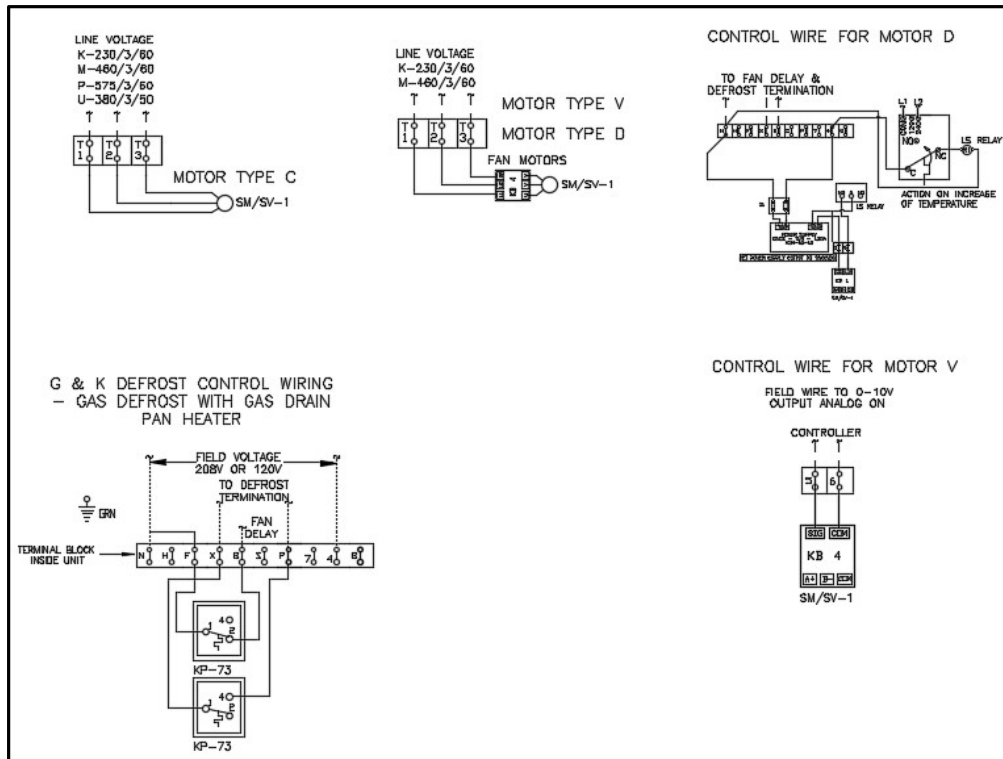

FIGURE 20: (K) KGG (2 PIPE) COOL GAS COIL AND DRAIN PAN WIRING



RECOMMENDED (SPST) FAN DELAY THERMOSTAT SETTINGS FOR KGE/HGG

TABLE - 7:

ROOM TEMPERATURE	RANGE	DIFFERENTIAL
0° F TO +35° F	45° F	15° F
BELOW 0° F	20° F	10° F

7.6 TWO SPEED MOTOR SEQUENCE OF OPERATION –

SM/SV coils use DUAL SPEED EC motors for fans in DOE applications, default being the High speed, the second speed is set as Minimum speed. Fans will be in Min speed/Full speed Or Off on below mentioned scenarios.

Minimum speed

- When the room temperature or the refrigeration setpoint is met the fan should operate at half speed.

Full Speed

- When the room temperature or refrigeration setpoint is not met and the fan should run at full speed

Fan off

- For EL/Gas defrost evaporators, during defrost fans should turn off

Krack gives the option of field control for this motor to run at minimum speed or it also gives the option of installed room thermostat to operate this as DUAL SPEED motor. When using the option of installed room thermostat, do not use the same thermostat to control the LLSV.

For DUAL SPEED operation SM/SV coils comes with 10V power supply and a Relay named LS relay installed in the panel. When using installed thermostat, the SPDT switch of the thermostat will energize the LS Relay. This relay will close the contact of the 10V power supply to the motor, thus supplies 10V to motor and Motor will run in low speed. When the room temperature is above the setpoint and will not energize the LS relay, when the room temperature is met the SPDT switch of the thermostat will energize the LS relay and send 10V signal to motor and make motor to run at minimum speed.

When using the field controller, the motor low speed is controlled through an output, the output may energize or de-energized based on room temperature input. LS relay will be energized only when the controller energized or de-energized the connected output.

When using the field-installed thermostat, the same concept of installed thermostat will be applicable.

7.7 VARIABLE SPEED MOTOR SEQUENCE OF OPERATION

Variable speed motor need 0-10V signal from field, 0-10V signal wires will be connected to terminal allotted in the Evaporator panel (Terminal A0+ & A0-). 0V being the Maximum speed and 10V being minimum speed. Speed varies based on the analog signal received by motor,

MOTOR SPEED - TABLE 8:

SM - MOTOR RPM	
MAX SPEED = 850 RPM	MIN SPEED = 425 RPM
SV - MOTOR RPM	
MAX SPEED = 1140 RPM	MIN SPEED = 450 RPM

7.8 VARIABLE SPEED MOTOR WITH SYSTEM 450 – SEQUENCE OF OPERATION

An installed System 450 C450CPN-4 controller will be utilized to supply 0-10V signal to Variable speed motor. Temperature sensor installed in the evaporator and wired to the System 450 control module will be utilized to measure the box temperature.

7.8.1 SYSTEM 450 PARAMETERS –

Set Point (SP) – is the target value that the control system drives toward. Set point at which Fan motor will run at full speed. – Target Box Temperature

End Point (EP) – is the maximum deviation from the target value. Setpoint at which Fan motors will run at Minimum speed – **Target Box Temperature – 5°F**

Output at Setpoint (OSP) – is the signal strength level of the analog output when the input sensor is at Setpoint (SP). The OSP is expressed as a percentage (0 to 100%) of the full-scale output. **Output signal strength at setpoint, i.e. Analog signal at setpoint. 0% - 0V**

Output at Endpoint (OEP) – value (OEP) is the signal strength level of the analog output when the input sensor is at the End Point (EP). The OEP is expressed as a percentage (0 to 100%) of the full-scale output.

Output signal strength at endpoint, i.e Analog signal at endpoint. 100% - 10V

Fan motor will receive 0V signal at Setpoint (SP) from system 450 controller, so the fans will run at full speed. At Endpoint (EP) fans will receive 10V signal, so the fans will run at minimum speed.

The analog signal varies between setpoint to endpoint proportionally based on the box temperature measured by installed temperature sensor thus varies the fan speed proportionally.

Signal amplifier is used enhance the analog signal strength from System 450 and then feed the signal to Motor to vary the fan speed. (Signal amplifier needed for KR, GH, GL and LH evaporator coils only)

Sensor Failure Mode –

System 450 allows you to select the mode of operation for your control system in the event of a sensor (or sensor wiring) failure of the sensor that the outputs reference. Set **SNF as OFF**. Analog output SNF OFF = Output Signal Strength at Setpoint (OSP). i.e Analog output will fail at OSP setpoint. Sending 0V signal to motor.

7.8.2 FIGURE 21: – WIRING DRAWING OF EVAPORATOR WITH SYSTEM 450 –

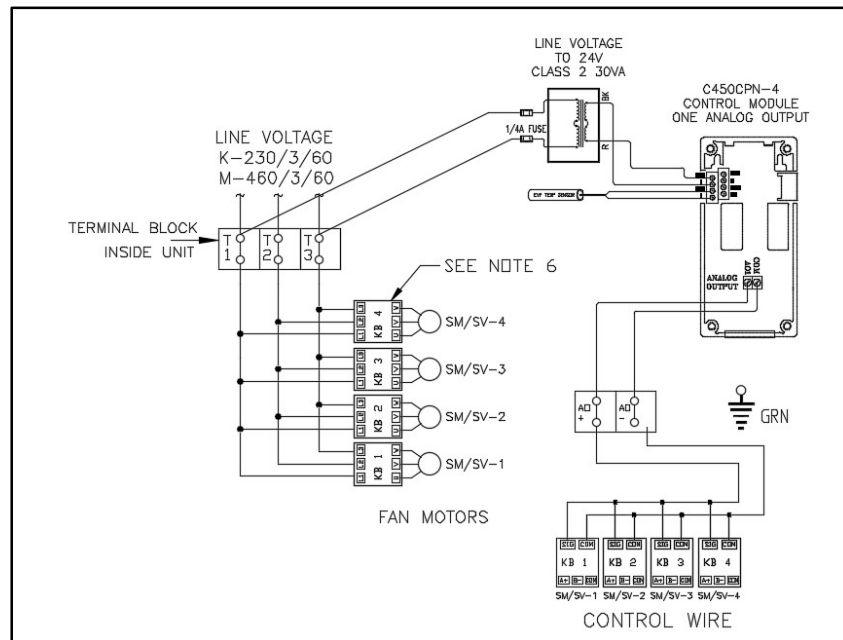

7.9 KB DRIVE SPECIAL SETTING

7.9.1 FIGURE 22: FACTORY INSTALLED JUMPER -

Make sure there a Jumper (#18 Gauge wire) installed between FWD and COM switches, to allow the Motor to run.

TERMINAL BLOCK TB1 CONNECTIONS AND JUMPERS J1/J2 SETTINGS

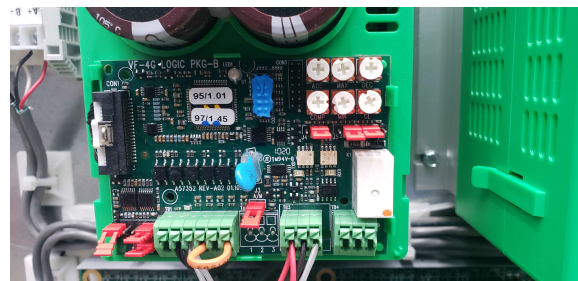
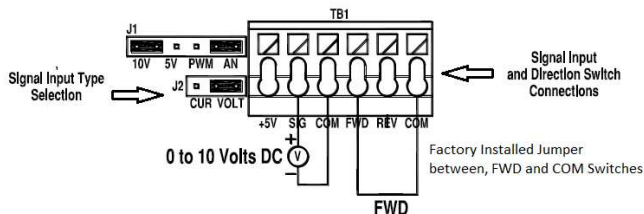

SPECIAL NOTE FOR FAILURE MODE – IN THE EVENT OF A DRIVE FAILURE OR SUSPECTED FAILURE, THE DRIVE SHOULD NOT BE BY-PASSED. THE MOTOR WILL NOT OPERATE WITHOUT THE DRIVE. DAMAGE TO THE MOTOR MAY RESULT.

7.10 INTERLOCKING SINGLE COMPRESSOR UNIT WITH KRACK COIL

When a single compressor unit utilized with Krack evaporators, Evaporator fan should run at full speed whenever the compressor is running. i.e, when using evaporator with DUAL SPEED motor fans, and variable speed motor fans the fan speed should not modulate when the compressor is running, fan speed can modulate only when compressor is turned off due to system operation.

When Krack Evaporator coils used with Single compressor units from Hussmann (H series and C series), there is provision given to interlock the compressor with evaporator fans. Single compressor units use contactor for compressor operation, a NC Aux contact attached to the main contactor will be used to interlock.

FIGURE 23: – Setup in Single compressor unit: -

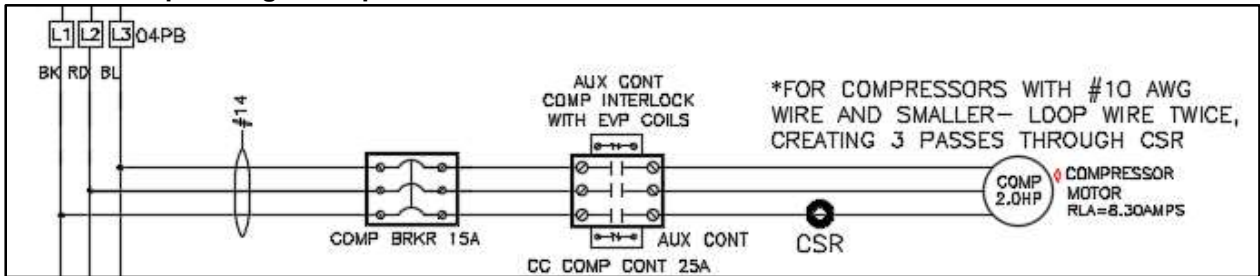

Aux contact wired to 2 terminal pins.

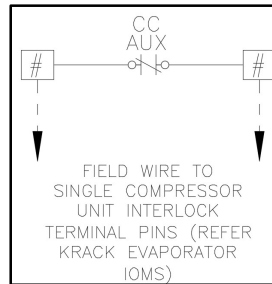
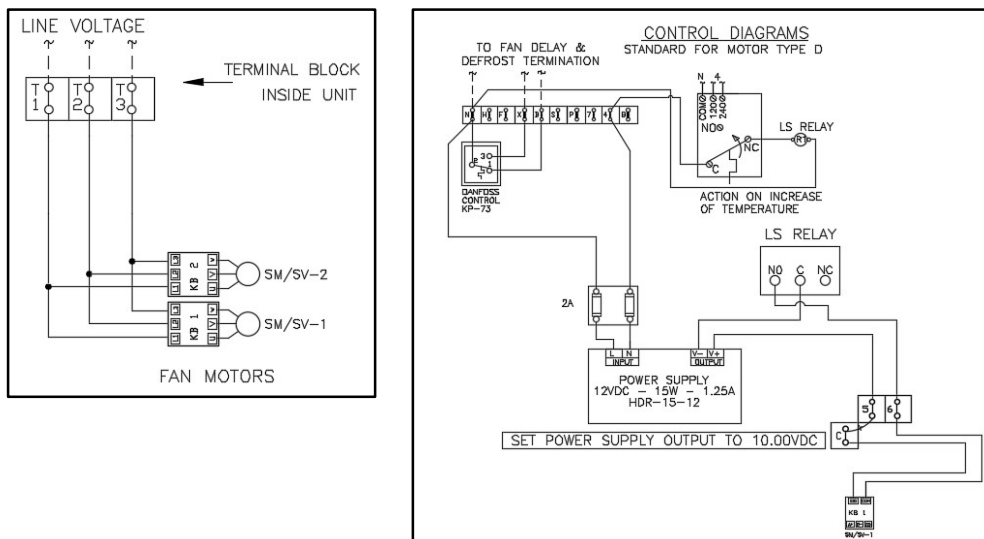
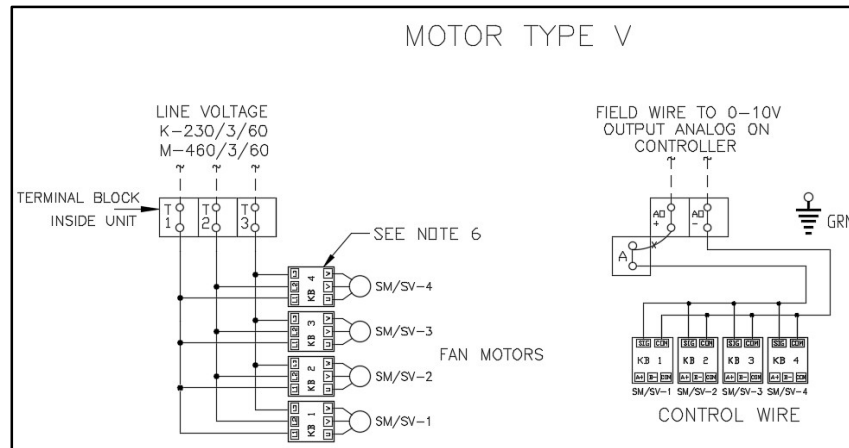

FIGURE 24: - DUAL SPEED MOTOR EVAPORATER COILS – (MOTORS WITH 10V EXTERNAL POWER SUPPLY)



In case of s DUAL SPEED Motor coils with 10V power supply – the Jumper between terminal 6 and C should be removed and then aux contact from single compressor unit wired in series. Whenever the compressor contactor energized the Aux contact energizes, and NC contacts changes state to NO, there by OPEN the 10V power supply circuit. So, whenever compressor is ON, fans will never go to low speed mode, even getting signal from Room thermostat or filed controller.

FIGURE 25: - VARIABLE SPEED MOTOR EVAPORATER COILS –



In Case of Variable speed motor coils – the Jumper between terminal A0+ and A should be removed and then aux contact from single compressor unit wired in series.

Whenever the compressor contactor energized the Aux contact energizes, and NC contacts changes state to NO, there by OPEN the analog 0-10V signal circuit. So, whenever the Controller sends the analog signal it goes through Aux contact, and make sure that compressor is ON and there by deactivates the analog signal circuit. So, when compressor is ON then fans will never be able to modulate, though Controller telling fans to modulate.

8 START UP

8.1 PRE-STARTUP

After the installation is completed, a review of the following items should be performed before the system is placed into operation:

Check electrical connections, fan blade set screws, fan motors, guards and all other fasteners for tightness. Be sure the thermostatic expansion valve bulb is properly located, strapped and insulated.

With the system operating, check the supply voltage. It must be within +/- 10% of the voltage marked on the unit nameplate.

For electric defrost systems check the defrost timer to see that it is set for the correct time of day and the starting pins have been installed (normally two per day). The defrost should be scheduled for times when the freezer doors are not likely to be open.

When the system is first started up, the box temperature is typically above the opening temperature of the fan delay thermostat. The fans may remain off for a lengthy period of time. To prevent this, it is permissible to install a temporary jumper wire between terminals "F" and "B" or "N" and "B" depending on the unit wiring arrangement. Once the box temperature is below +25°F the jumper wire should be removed.

8.2 OPERATION CHECKOUT

With the system operating, check the supply voltage. The voltage must be within +/- 10% of the voltage marked on the unit nameplate and the phase to phase unbalance should be 2% or less.

LISTEN CAREFULLY to the unit to make sure there are no unusual sounds. Sounds such as a noisy motor, the fan(s) scraping on the housing, or loose fasteners allowing parts to rattle need to be addressed immediately before continued unit operation.

Check the room THERMOSTAT setting. Be sure it functions properly.

For DIRECT EXPANSION systems let the system balance out at the desired room temperature and check the operation of the expansion valve by properly measuring the superheat at the sensing bulb. As much as thirty minutes may be required for the new balance to take place after an adjustment is made.

For BRINE or GLYCOL COOLING systems keep the closest vent to the coil open while the fluid fills the coil to allow trapped air to escape. Close the vent valve once fluid flows out of the valve and check for water hammer in the coil.

With HOT GAS DEFROST systems allow the coil to frost, then manually advance the defrost timer to initiate a defrost cycle. Observe the defrost cycle to see if all controls are functioning properly and that the coil is clear of all frost before the system returns to refrigeration. Adjust the time clock pins if necessary. Reset the defrost timer to the correct time of day. A defrost cycle is only needed when the frost build up is such that it impedes the airflow through the coil. The defrost requirements will vary on each installation and may change depending on the time of the year and other conditions.

With ELECTRIC DEFROST systems allow the coil to frost then manually advance the defrost timer to initiate a defrost cycle. Observe the defrost cycle to see if all controls are functioning properly and that the coil is clear of all frost before the system returns to refrigeration. Adjust the time clock pins if necessary. Reset the defrost timer to the correct time of day. A defrost cycle is only needed when the frost build up is such that it impedes the airflow through the coil. The defrost requirements will vary on each installation and may change depending on the time of the year and other conditions.

9 PREVENTATIVE MAINTENANCE

A preventive maintenance schedule should be established as soon as the SM/SV Series unit is installed. The unit should be inspected periodically for proper operation and buildup of frost and debris.

WARNING: All power supply to the unit must be shut off before opening any compartments, cleaning or performing maintenance.

9.1 DRAIN PAN

Inspect and clean the drain pan to insure free drainage of condensate. The drain pan should be cleaned regularly with warm water and soap.

If the drain pan needs to be removed, support the long dimension of the pan from underneath with a minimum of two 4x4s for one and two fan units, or two 6x6s for three and four fan units, so the outer sheet metal skin does not buckle and become damaged. **Do not point load the center of the support beam.** For longer pans more than one lifting device may be needed to keep the pan balanced when lifting. If the drain pan uses hot gas defrost make sure the coil is completely pumped out and isolated with hand valves to prevent refrigerant from escaping to the atmosphere. Remove electric wires if the unit has an electric defrost drain pan. Remove the drain line so that it is out of the way of the pan when it is being lowered. Remove the drain pan attachment bolts from the bottom of the evaporator unit and slowly lower the pan from the unit. Assemble pan in reverse order. Replace hot gas inter-piping gaskets before tightening flange bolts.

9.2 COIL AND CABINET

Clean the coil, fan cabinet, fans, and fan guards with warm water and soap. A low-pressure water hose is recommended to avoid water entering into electrical components and causing equipment failure.

The evaporator coil should be checked once a month for proper defrosting. Many variables affect coil frosting such as room temperature, type of product being stored or processed, how often new product is brought in, and the length of time the door to the room remains open. Summer conditions of high humidity can cause heavier frost loads and it may be necessary to change the number of defrost cycles seasonally.

9.3 FAN GUARD OR LONG THROW ADAPTER REPLACEMENT

To remove a fan guard or long throw adapter for fan-motor maintenance, or for guard or adapter replacement, make sure all electrical power to the unit has been turned off before any work is performed. Remove the two nuts on the lowest part of the guard or adapter first. While supporting the guard or adapter to the unit remove the top two nuts. Remove the guard or adapter. Reassemble in the reverse order.

9.4 FAN REPLACEMENT

If a fan is out of balance, damaged, or needs to be replaced, the unit does not need to be at floor level for maintenance. Make sure all electrical power to the unit has been turned off before any work is performed. Remove the fan guard as described in Section 10.3. Loosen the two bolts from the bushing that hold the fan onto the motor shaft. Remove the fan. Clean and debar the motor shaft if necessary.

Place the new fan, onto the motor shaft, tighten bolts. Reattach the fan guard and motor assembly to the unit.

9.5 UNIT MOTOR REPLACEMENT

Make sure all electrical power to the unit has been turned off before any work is performed. To replace a motor a lifting device may be required for the heavy motors. Remove the fan guard and fan as described in Sections 10.3 and 10.4. The motor is wired to the disconnect switch, or control panel, through flexible conduit. Remove the motor cover and disconnect the motor leads. Unscrew the flexible conduit from the motor move the conduit out of the way.

For safety, the motor should be supported before the fan guard bolts and nuts are taken apart. Remove the fan guard bolts and remove the motor assembly from the housing.

Assemble the replacement motor in fan guard. Reinstall assembly in the unit. Connect the wires to the motor following the wiring schematic for the motor. Make certain the motor is wired for the correct supply voltage. Replace the motor electrical cover. Center the fan in the orifice. When the motor assembly is centered tighten bolts and nuts to hold the motor guard assembly in place. Only slightly tighten the bolts at this time in case the motor needs to be adjusted after the fan is installed.

When starting the motor make sure the fan is rotating in the proper counterclockwise direction. If the fan rotates clockwise, stop the motor, shut off all power to the unit, and change the motor wiring for counterclockwise rotation.

9.6 ELECTRIC DEFROST HEATERS

Inspect the electric defrost heater ends to determine if they are operating. A heater will be operating properly when the heater is observed to be glowing during the defrost cycle. If a heater rod is cold during the defrost cycle it will need to be replaced.

Coil heaters require horizontal removal from ends of the unit. On two or three fan unit's, heater rods are on both ends of the unit. Turn off all electrical power on the unit. Remove heater wire from terminal block and note where original wires were located. Rotate the heater rod so that the heater and retainer clip can be slid through the coil endplate slot. Remove clip from the old heater rod and install on the new heater rod in approximately the same location as the original heater. Install new heater rod in the coil original coil slot, rotate the rod 90°, and replace the wires in the positions of the original wires in the terminal block.

Turn off all electrical power on the unit.

Drain pan heaters require the drain pan to be removed. Support the long dimension of the pan from underneath with a minimum of two 4x4s for one and two fan units or two 6x6s for three and four fan units so the outer sheet metal skin does not buckle and become damaged. For longer pans more than one lifting device may be needed to keep the pan balanced when lifting. Remove heater's wires from terminal blocks. Remove the drain line so that it is out of the way of the pan when it is being lowered. Remove the drain pan attachment bolts from the bottom of the evaporator unit and slowly lower the pan from the unit. Remove clips from the heater's hold down brackets and remove brackets. Replace the heater. Replace the hold down brackets and assemble the pan in reverse order. Rewire heaters in original terminal blocks.

10 TROUBLESHOOTING CHART

TABLE 9: TROUBLESHOOTING CHART

PROBLEM	POSSIBLE CAUSES	CORRECTIVE ACTION
Fans will not operate.	Unit not wired properly. Defective motor. Defective defrost timer, termination thermostat or fan delay switch. Room temperature too high for use of fan delay switch.	Check wiring. Replace motor. Replace defective component. Jumper fan delay switch. Terminals F to B.
Ice forming on ceiling. Steaming during defrost.	Too many defrosts per day. Too long defrost cycle. Defective termination Thermostat or defrost timer.	Observe frost build up on coil, change to fewer defrost per day. Replace defective component.
Excessive buildup of frost on coil.	Too few defrost times. Defrost cycle too short. Too high humidity in cooler.	Add more defrost cycles to timer. Extend defrost time on timer. Limit access to cooler, do not prop doors open during stocking.
Accumulation of ice in drain pan.	Drain line plugged. Defective heater.	Clean drain line. Make sure drain line is insulated properly. Replace heater.

11 REPLACEMENT PARTS LIST

FIGURE 26: –

Listed below are the major replacement parts. When ordering parts, it is imperative that you provide the complete model and serial number of the unit to the Parts Department.

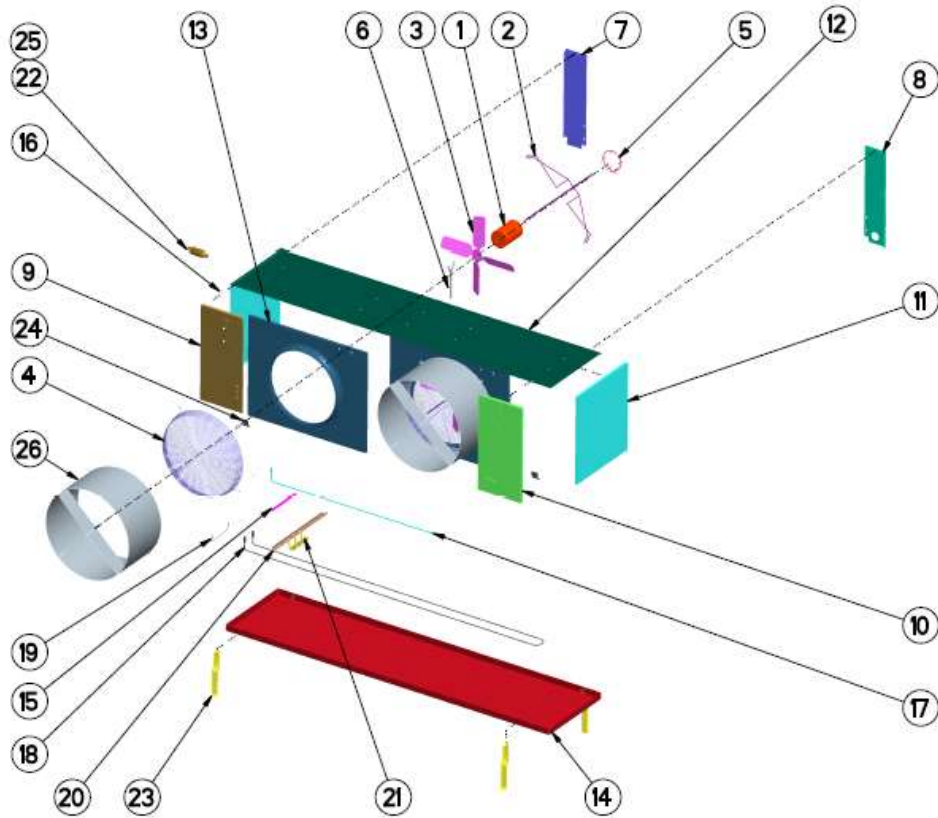

TABLE 10: REPLACEMENT PARTS LIST

Item	General Description	Options Description	Krack BOM Part Number
1	MOTOR	SM 1 HP 208-230/460/60/3 850 RPM	11503IN
		SM 1 HP 575/60/3 850 RPM	E205307IN
		SM 1.5 HP 380/60/3 1140 RPM	E205492IN
		SV 1.5 HP 230/460/60/3 1140 RPM	E205492IN
		SV 1.5 HP 575/60/3 1140 RPM	E206689IN
	SM and SV - 3PH VS/DUAL SPEED MOTOR	MOTOR-1.5HP 240V 50-60HZ 3P 120-1200RPM	3055269
		MOTOR-1.5HP 460V 50-60HZ 3P 120-1200RPM	3080452
SM and SV – KB Drive	DRIVE -KB-460/380V -MX LEAD FAN -SV	3148733	
	DRIVE -KB-208V -LEAD FAN MX-SV	3148734	
	DRIVE -KB-460/380V-SM	3148735	
	DRIVE -KB-208V-SM	3148736	
2	MOTOR MOUNT BRACKET		E280793
3	FAN BLADE	SM	11273
		SV	E205493
4	FAN GUARD		E280792
5	MOTOR RING 56 FRAME		80034
6	WIRE HARNESS	1 FAN	80576
		2 FAN	80578
		3 FAN	80580
		4 FAN	80582
7	LEFT BACK CORNER PANEL	1-2 FAN	69018
		3-4 FAN	69019
8	RIGHT BACK CORNER PANEL	1-2 FAN	69020
		3-4 FAN	69021
9	LEFT FRONT CORNER PANEL	1 FAN	69025
		2 FAN	69026
		3-4 FAN	69027
10	RIGHT FRONT CORNER PANEL	1 FAN	69022
		2 FAN	69023
		3-4 FAN	69024
11	ACCESS DOOR	1-2 FAN	69031
		3-4 FAN	69032
12	TOP PANEL	1 FAN	69033
		2-3 FAN	69034
		4 FAN	E269492
13	FAN PANEL	1-2 FAN	69029P
		3-4 FAN	69030P
14	DRAIN PAN	SM-1 INNER PAN VERT DRAIN	C69036
		SM-2/3 INNER PAN VERT DRAIN	C69037
		SM-1 DP INS 230V H/KGE, EDL	CE269322
		SM-2/3 DP INS 230V H/KGE, EDL	CE269324
		SM-1 DP INS 460V H/KGE, EDL	CE269323
		SM-2/3 DP INS 460V H/KGE, EDL	CE269325
		SM-1 K/HGG INS DRAIN PAN ASY	CE269105A
		SM-2/3 K/HGG INS DRAIN PAN ASY	CE269110A
		SM-1 DRAIN PAN INSULATED	CE269141
		SM-2/3 DRAIN PAN INSULATED	CE269142

		SM-4 INNER DRAIN PAN SM-4F DP INS 230V H/KGE EDL SM-4F DP INS 460V H/KGE EDL SM4 INS.DRAIN PAN ASSY K/HGG SM-2/3 DP INS 575V H/KGE, EDL SM-4F DP INS 575V H/KGE EDL SM-1 DP INS 575V H/KGE, EDL DRAIN PAN SS VERT CONN DRAIN PAN SM-2/3 SS SM-2/3 SS DPINS 460V H/KGE, EDL SM-1 K/HGGINS DRAIN PAN ASY SS SM-1 DRAIN PAN INSULATED SS SM-2/3 SS DRAIN PAN INSULATED SM-4 INNER DRAIN PAN SS SM-4F DP INS DT ERH HEATER 4.65 KW 230 VOLT DT ERH HEATER 4.65 KW 460 VOLT DT ERH HEATER 4.65 KW 575 VOLT DT ERH HEATER 4.65 KW 380 VOLT HTR BRKT ERH 58.5" FAN SECT. HTR BRKT ERH 39" FAN SECTION KR95222 CK CTRL TERM BLOCK 10P KR07233 TERM BOARD 3P 10 LUG	E269495 E269490 CE269490A CE269520A E269525 E269490B CE269545 69036S 69037SS CE269325S E269105AS E269141S E269142S E269495S E269490C E313359 E313360 E313361 E313428 D255020 D255020A E206482 E313576
15	BRACKET FOR DRAIN PAN		E269334
16	THERMOSTATS	DEFROST TERM (14T32) HEATER SAFETY (14T21) FAN DELAY (14T31) KP-73 TSTAT A19ABC-37 PENN SPDT	E206100 10956 E201818 E205004 E312488
17	COIL HEATERS	1 FAN 230V 1 FAN 380V 1 FAN 460V 1 FAN 575V 2-3 FAN 230V 2-3 FAN 380V 2-3 FAN 460V 2-3 FAN 575V 4 FAN 230V 4 FAN 380V 4 FAN 460V 4 FAN 575V	69000 E201922 69001 E269546 69002 E201924 69003 E201305 E269502 E269503 E269504 E269505
18	DRAIN PAN HEATERS	1 FAN 230V 1 FAN 380V 1 FAN 460V 1 FAN 575V 2-3 FAN 230V 2-3 FAN 380V 2-3 FAN 460V 2-3 FAN 575V 4 FAN 230V 4 FAN 380V 4 FAN 460V 4 FAN 575V	E269328 E269329 E269330 E269544 E269331 E269332 E269333 E269524 E269498 E269499 E269500 E269501
19	HEATER CLIP	FACE BOTTOM	66317 66318

20	HEATER ANGLE		69120 69119
21	HEATER SUPPORT BRACKET		E269562
22	CHECK VALVE	1/2" 5/8" 7/8" 1-1/8" 1-3/8" 1-5/8" 2-1/8"	11852 11853 10930 11804 11086 E150087 E205552
23	SHIPPING LEG GLV 3.563 X 19.25		21776P
24	1X2.25X2.5 HINGE ZP		69113
25	CHECK VALVE KIT	0.5" 0.875" 1.125" 1.625" 2.125" 2.625" 2.625"	CE269381 CE269382 CE269383 CE269377 CE269378 CE269379 CE269380
26	AIR BOOSTER		CE269292
27	RELAY 240V	RELAY-30AMP DP/ST N.O. 120V RELAY TYCO T92P7A22-240V	0459304 1804241
28	10V Power Supply	POWER SUPPLY-10 VDC HDR-15-12	3115218
29	ROOM THERMOSTAT	RT 3 (Electronic) ETC111000	E206766
30	Temp Sensor for Box	A99BC-300 TEMP SENSOR (set189a)	E205564
31	Controller for VS speed motors	CTRL MODULE W/I AO C45CPN4C	3059162
32	AUX CONTACT FOR SINGLE COMP INTERLOCK	C320KG2 AUX CONT 1 NC 25-75A C320DPG01 AUX CONT 1 NC 90A	E209975002 E209976002



Use your QR reader to
reference current document
version on www.krack.com.



Krack, a Hussmann Corporation brand
1049 Lily Cache Lane, Suite A
Bolingbrook, Illinois 60440
Ph: 630.629.7500

www.krack.com
www.hussmann.com